

MAX[®] S-SERIES



MAX[®] S-400



MAX[®] S-500



MAX[®] S-650



MAX[®] S-400

[Assembly Instructions Manual](#) →

[Installation and Operation Manual](#) →

[Upgrade Manual](#) →

[Hydra 26 HD LED Manual](#) →





MAX[®] S-500

[Assembly Instructions Manual](#)



[Installation and Operation Manual](#)



[Upgrade Manual](#)



[Hydra 26 HD LED Manual](#)



MAX[®] S-650

[Assembly Instructions Manual](#) →

[Installation and Operation Manual](#) →

[Upgrade Manual](#) →

[Hydra 26 HD LED Manual](#) →





PRINTING INSTRUCTIONS

To print **only** the Assembly Instructions Manual, print pages 5-57.

Red Sea MAX[®] S-400/500 LED

Complete Coral Reef Systems



MAX[®] S-400/500 LED

Assembly Instructions | Montageanleitungen

Notice de montage | 安装指南

Index

Frame Rahmen Structure 框架	3
Cabinet Unterschrank Meuble 底柜	13
Positioning Ausrichtung Emplacement 摆放位置	25
Aquarium & Sump Aquarium & Filtersumpf Aquarium et decantation 水族箱和过滤缸	27
Pumps & Skimmer Pumpen & Abschäumer Pompes et écumeur 循环泵和蛋分	41
Lighting & Power Beleuchtung und Strom Eclairage et Power Center 照明设备和电源中心	45

Screw List | Liste der Schrauben | Liste des vis | 螺丝清单

Screw # Schraube # Vis # 螺丝 #	Picture Bild Dessin 图片	Description Beschreibung Description 介绍	Pack Paket Sachet 包装	Quantity Anzahl mfsdijf Quantité 数量
S (V) 1		Torx Head Rundkopf Tête ronde ST 5 x 12mm	A Screw Pack Schraubenpaket Sachet de vis 螺丝包	2 X 50
S (V) 2		Countersunk Senkkopf Tête fraisée ST 5 x 14mm	B Screw Pack Schraubenpaket Sachet de vis 螺丝包	28
S (V) 3		Countersunk Senkkopf Tête fraisée ST 4 x 35mm	B Screw Pack Schraubenpaket Sachet de vis 螺丝包	6
S (V) 8		Round Head Rundkopf Tête ronde ST 3.5 x 30mm	B Screw Pack Schraubenpaket Sachet de vis 螺丝包	3
S (V) 4		Countersunk Senkkopf Tête fraisée M4 x 25mm	Cabinet Parts Pack Paket für Unterschrank-Teile Visserie meuble 木柜板材螺丝包	8
S (V) 6		Countersunk Senkkopf Tête fraisée 4 x 16mm	Hinge Set Scharnier-Set Charnières 门铰链螺丝包	28
S (V) 3		Countersunk Senkkopf Tête fraisée ST 4 x 35mm	Pipe Clip Pack Rohrclip-Paket Fixation tuyaux 管夹螺丝包	3
S (V) 5		Countersunk Senkkopf Tête fraisée ST 6 x 16mm	Pipe Clip Pack Rohrclip-Paket Fixation tuyaux 管夹螺丝包	2
S (V) 7		Countersunk Senkkopf Tête fraisée ST 5 x 35mm	MAX® 500 Drawer Sliders Gleitschienen Glissières du tiroir 抽屉滑轨螺丝包	4

#1

Frame | Rahmen

Structure | 框架

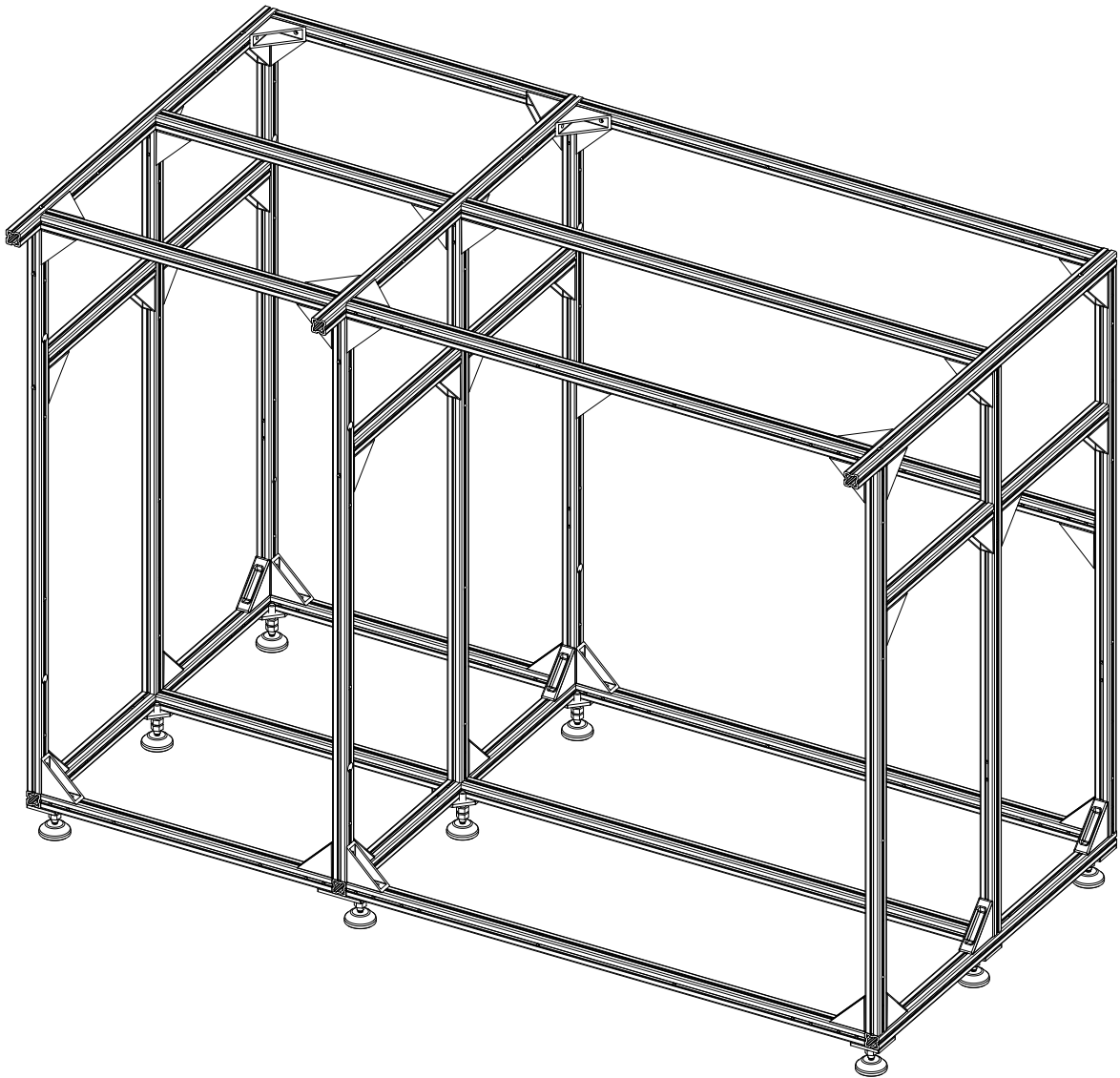

Parts | Teile | Éléments | 部件

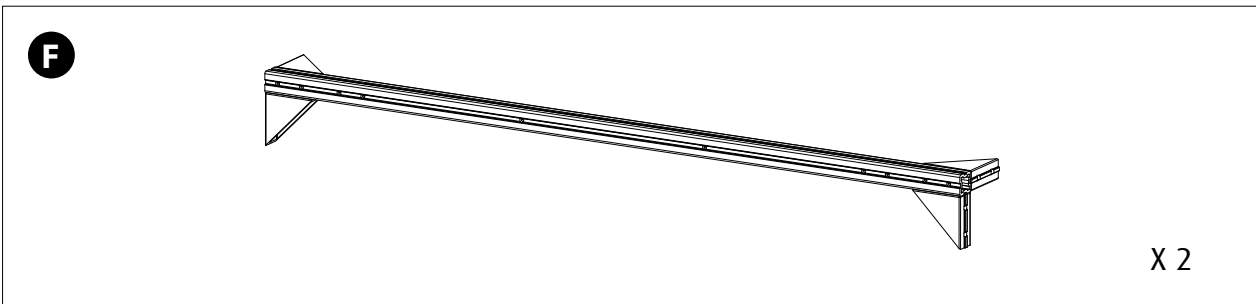
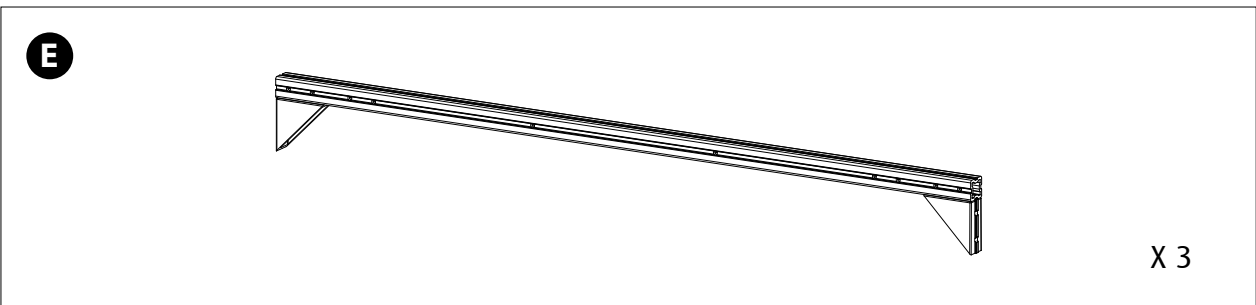
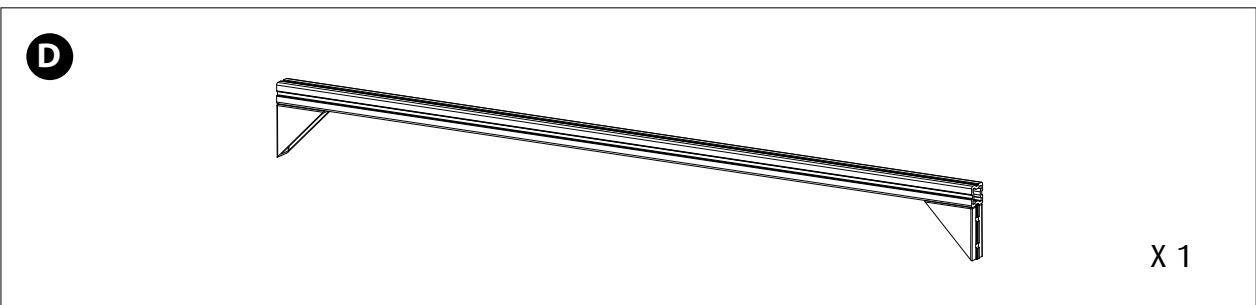
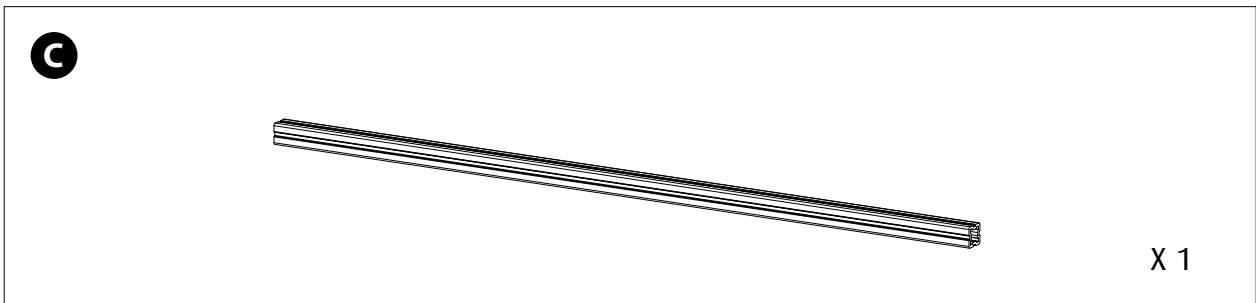
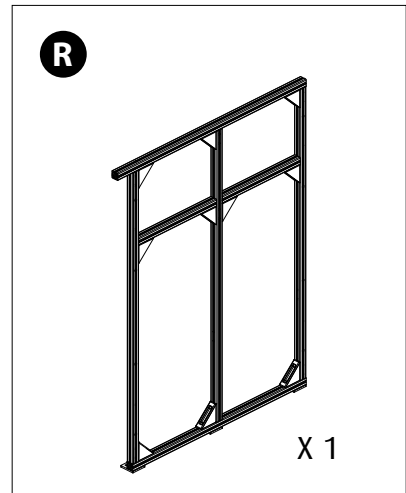
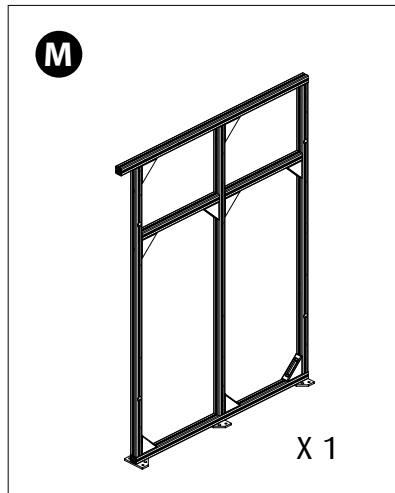
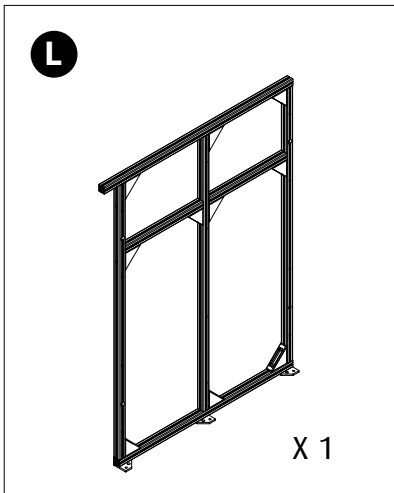

H



X 1

J



X 1

K



X 2

N



X2

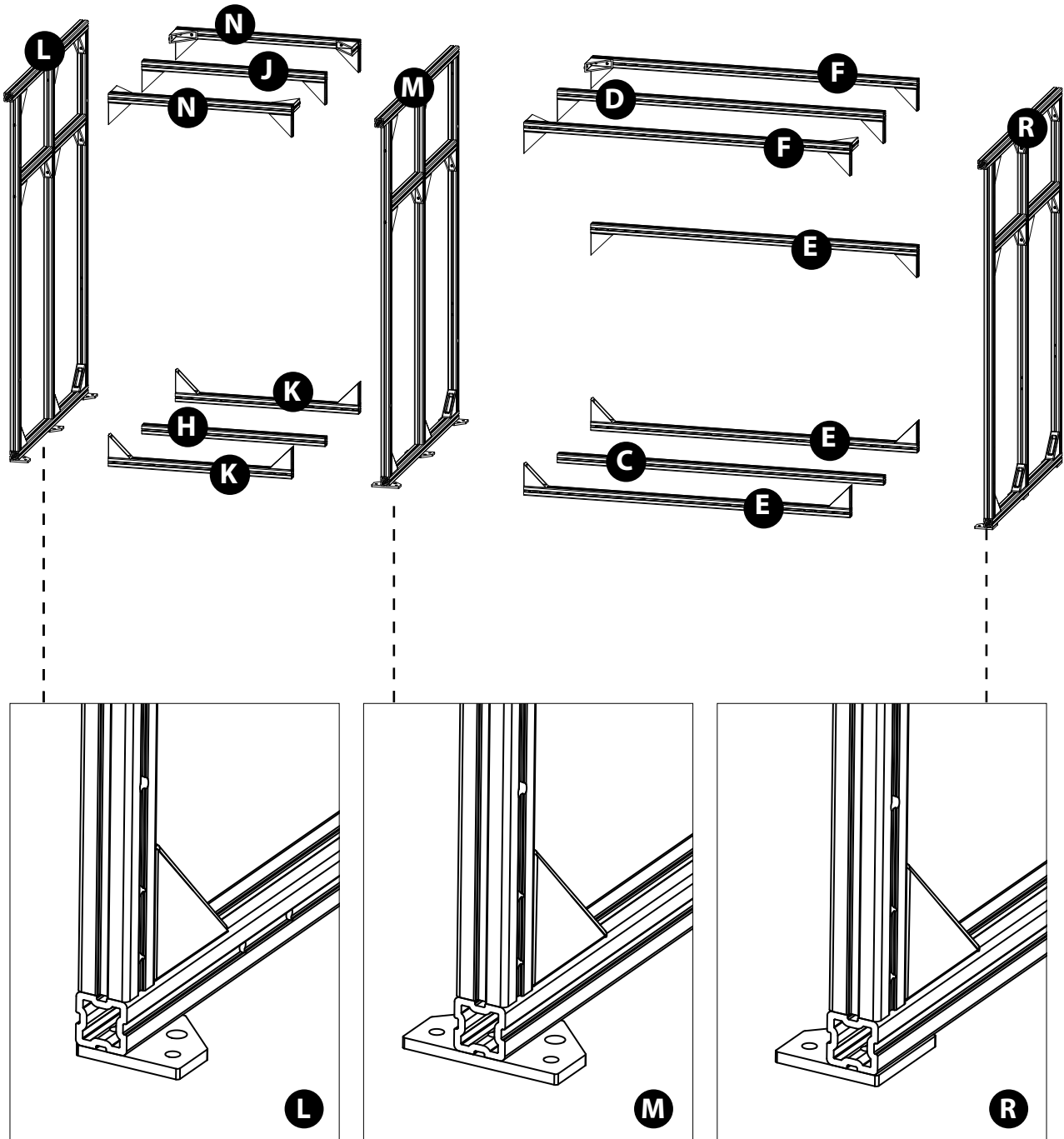
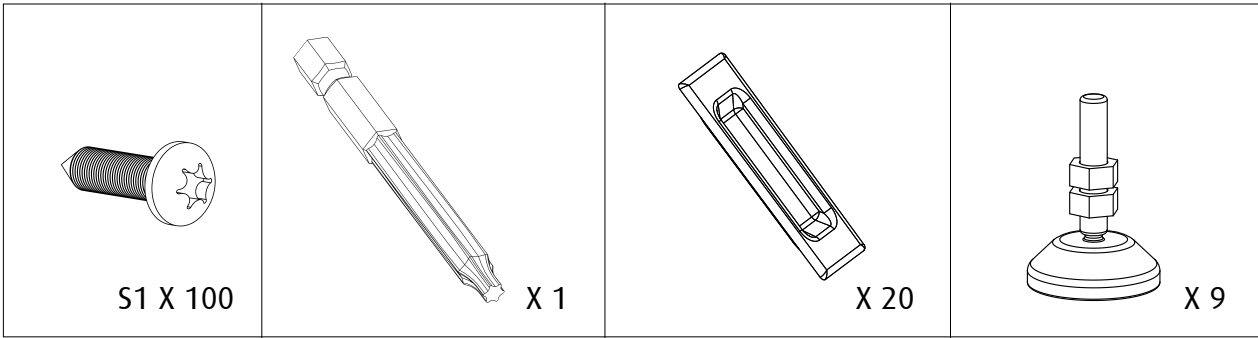

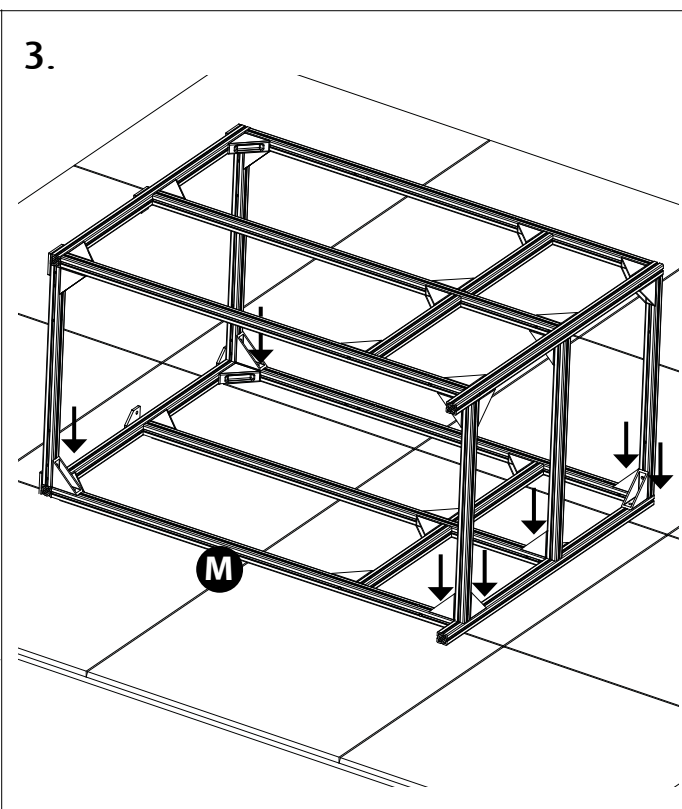
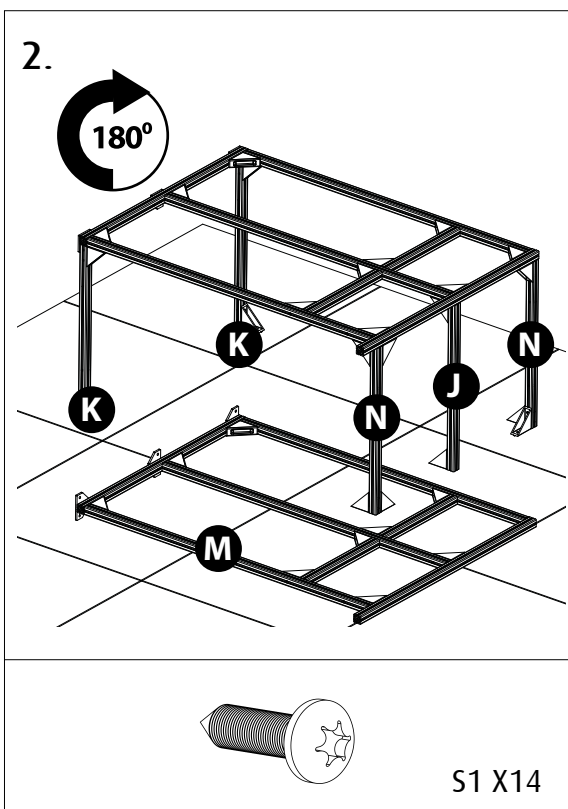
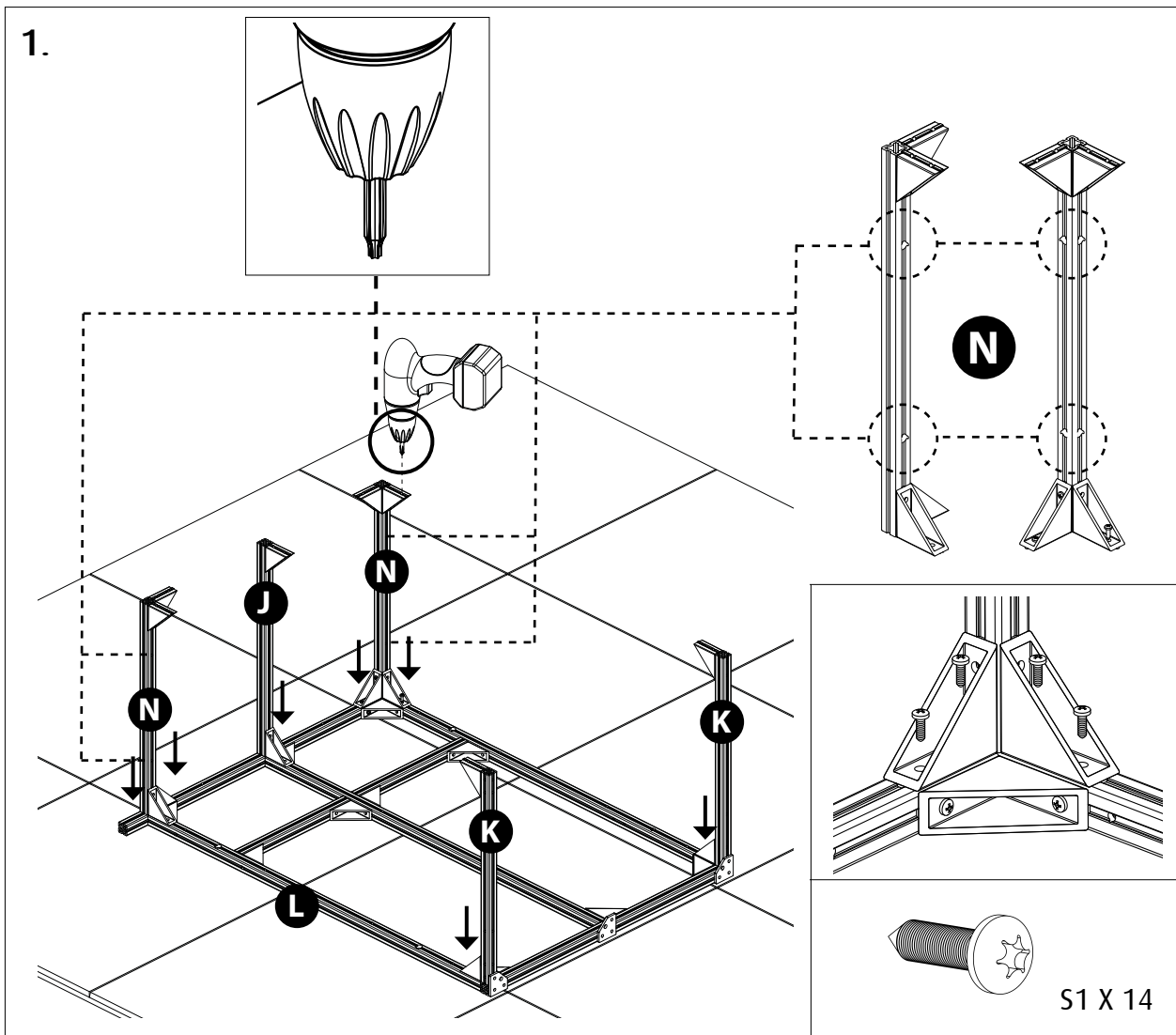

4.

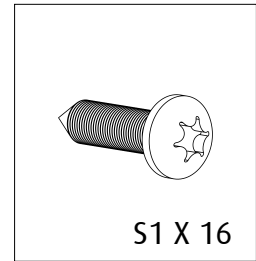
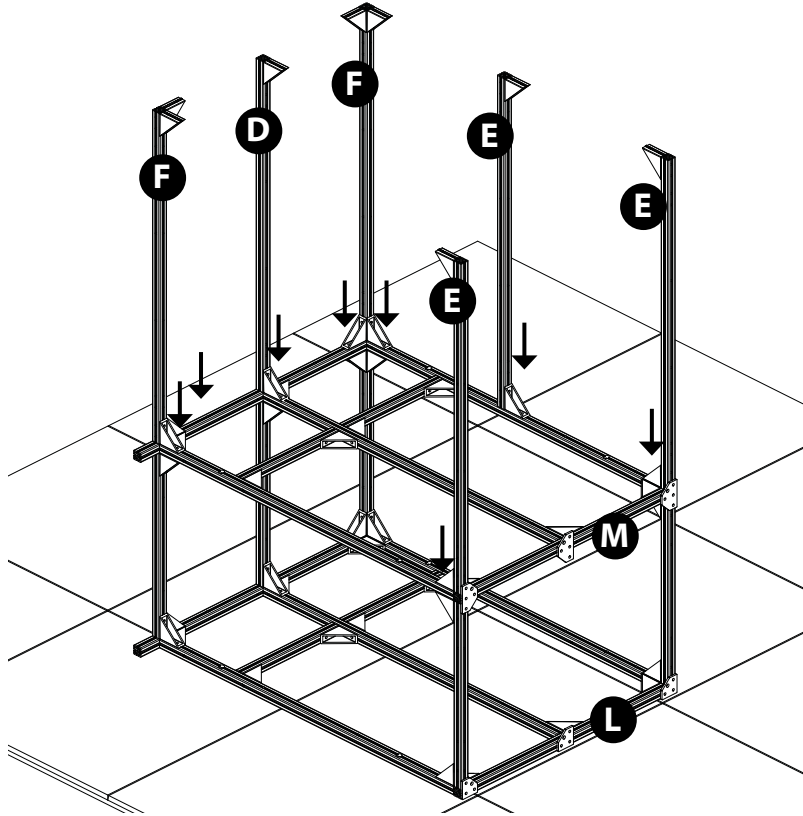

S1 X 16

5.

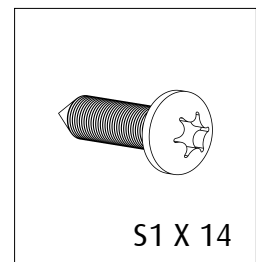
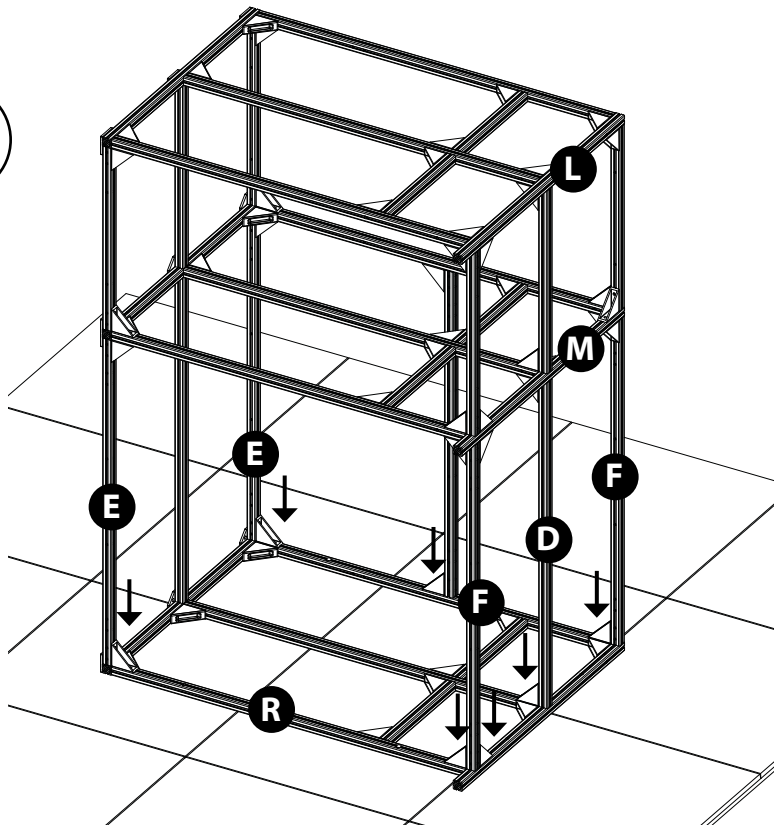
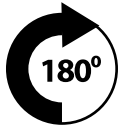

S1 X 14

6.

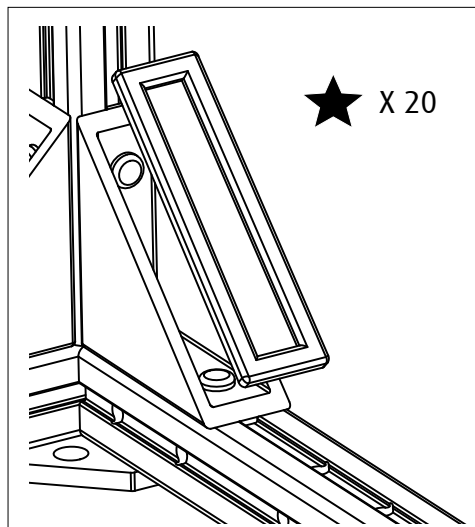
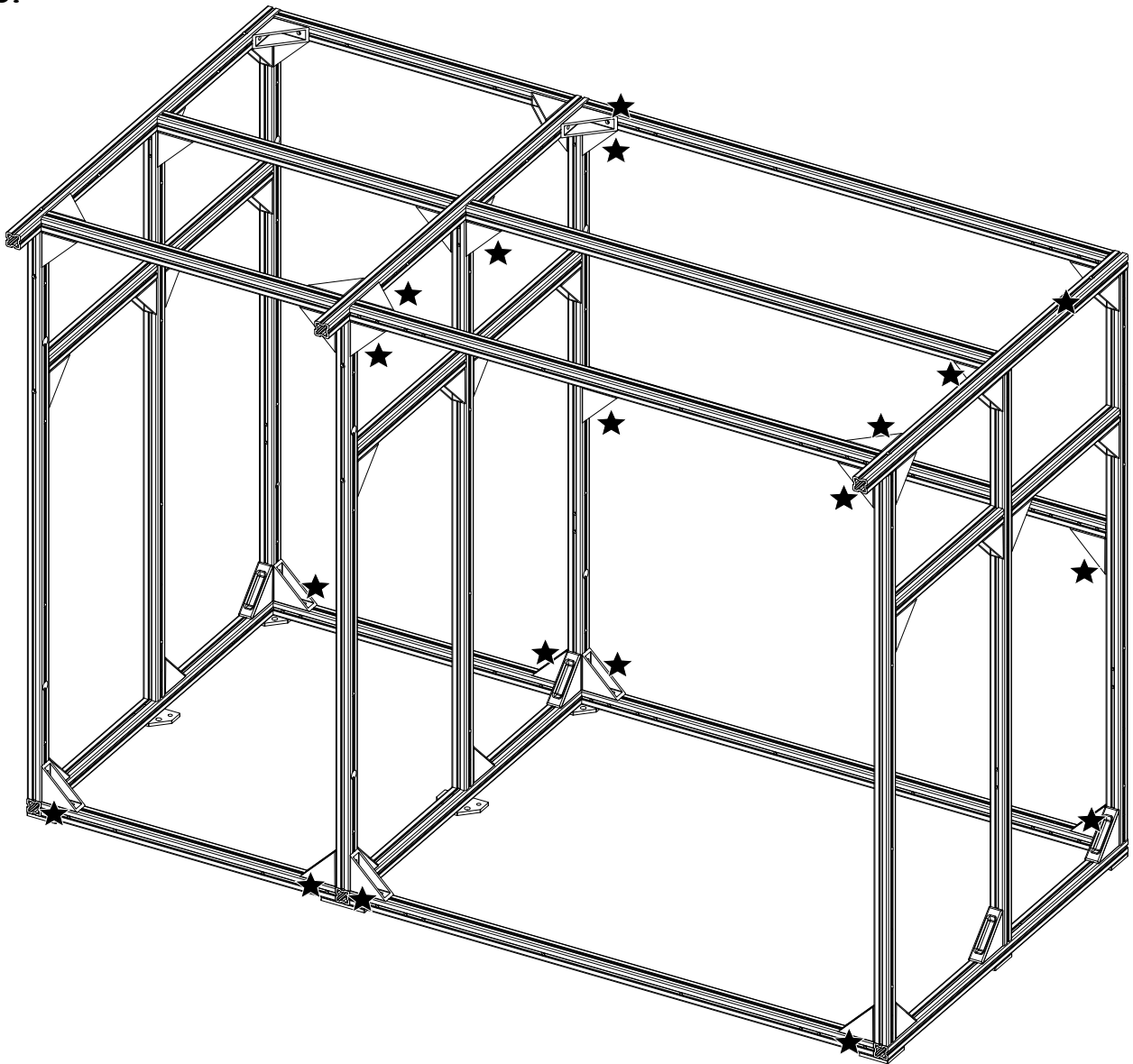

7.

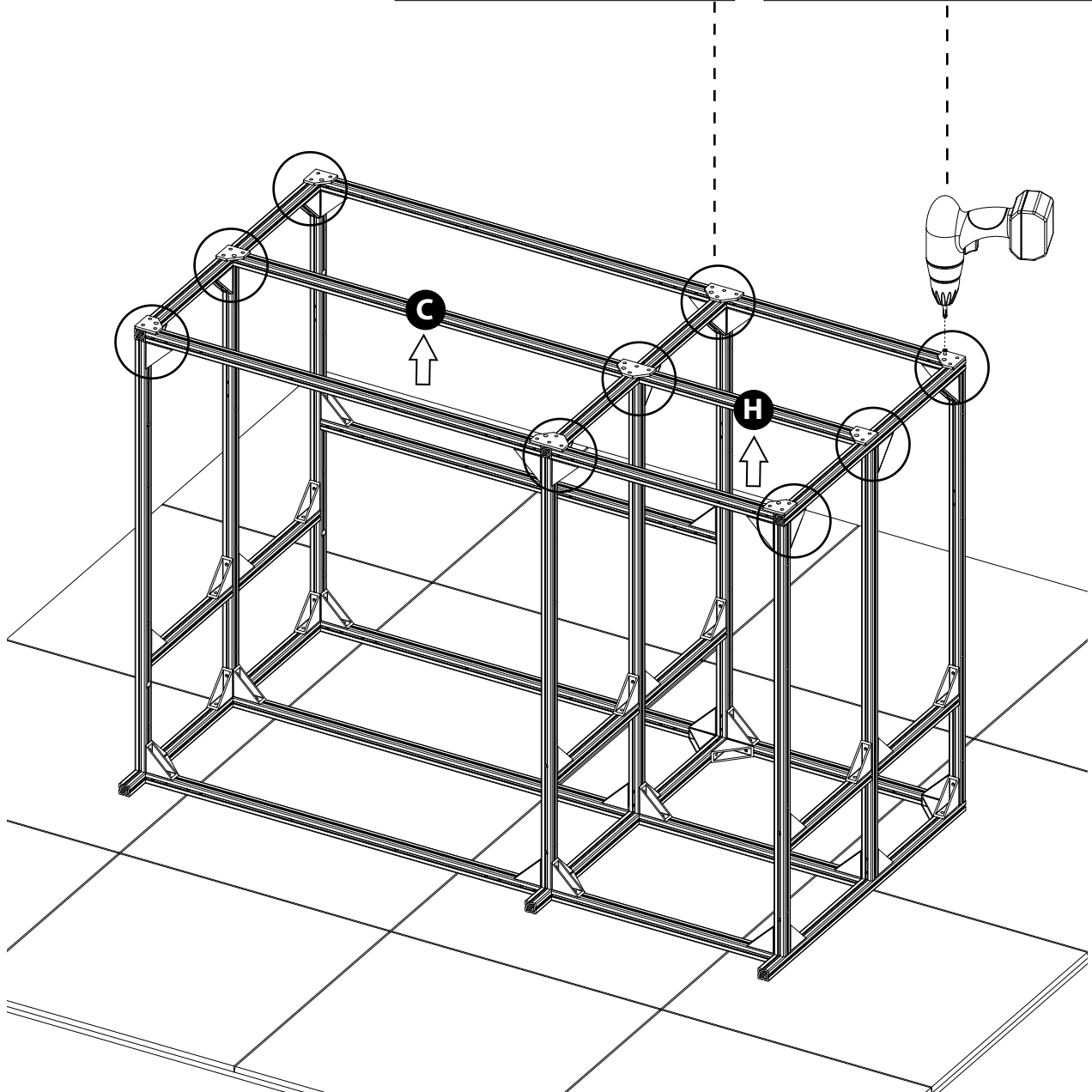
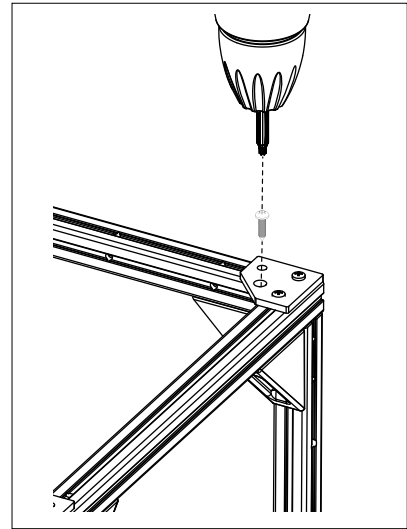
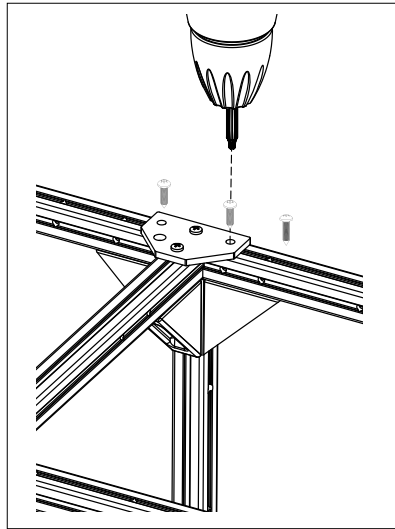
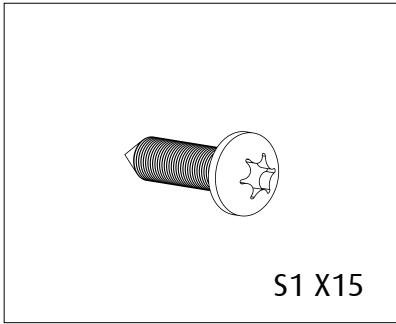

8.

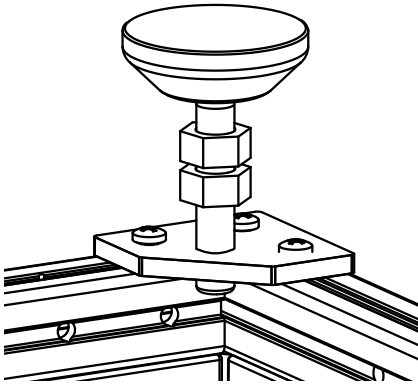

X 4

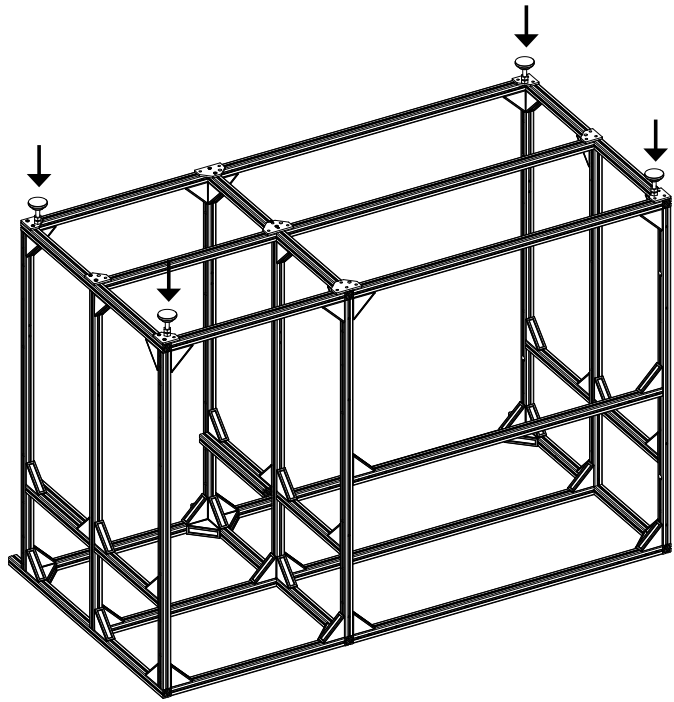

9.

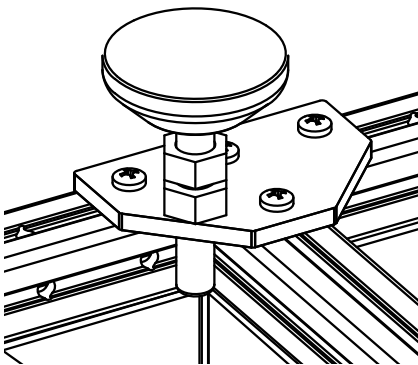

X 5

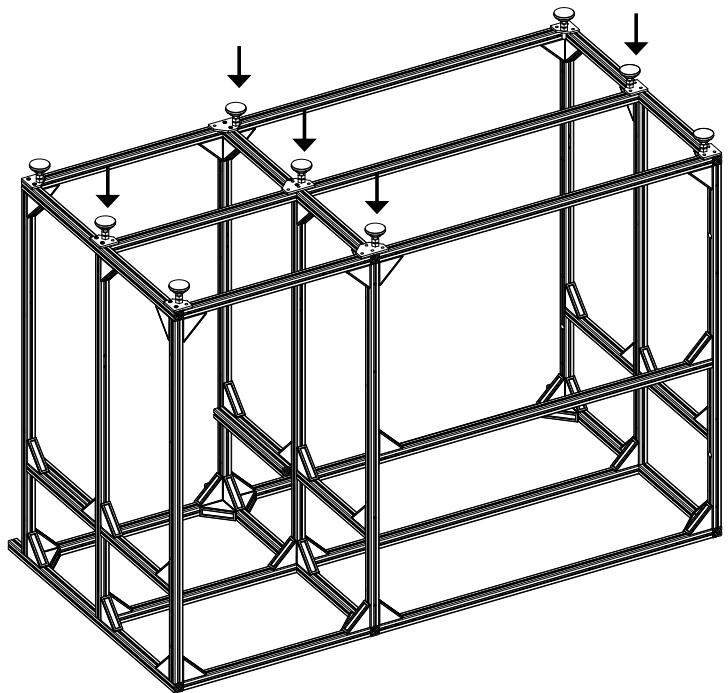

#2

Cabinet | Unterschrank

Meuble | 底柜

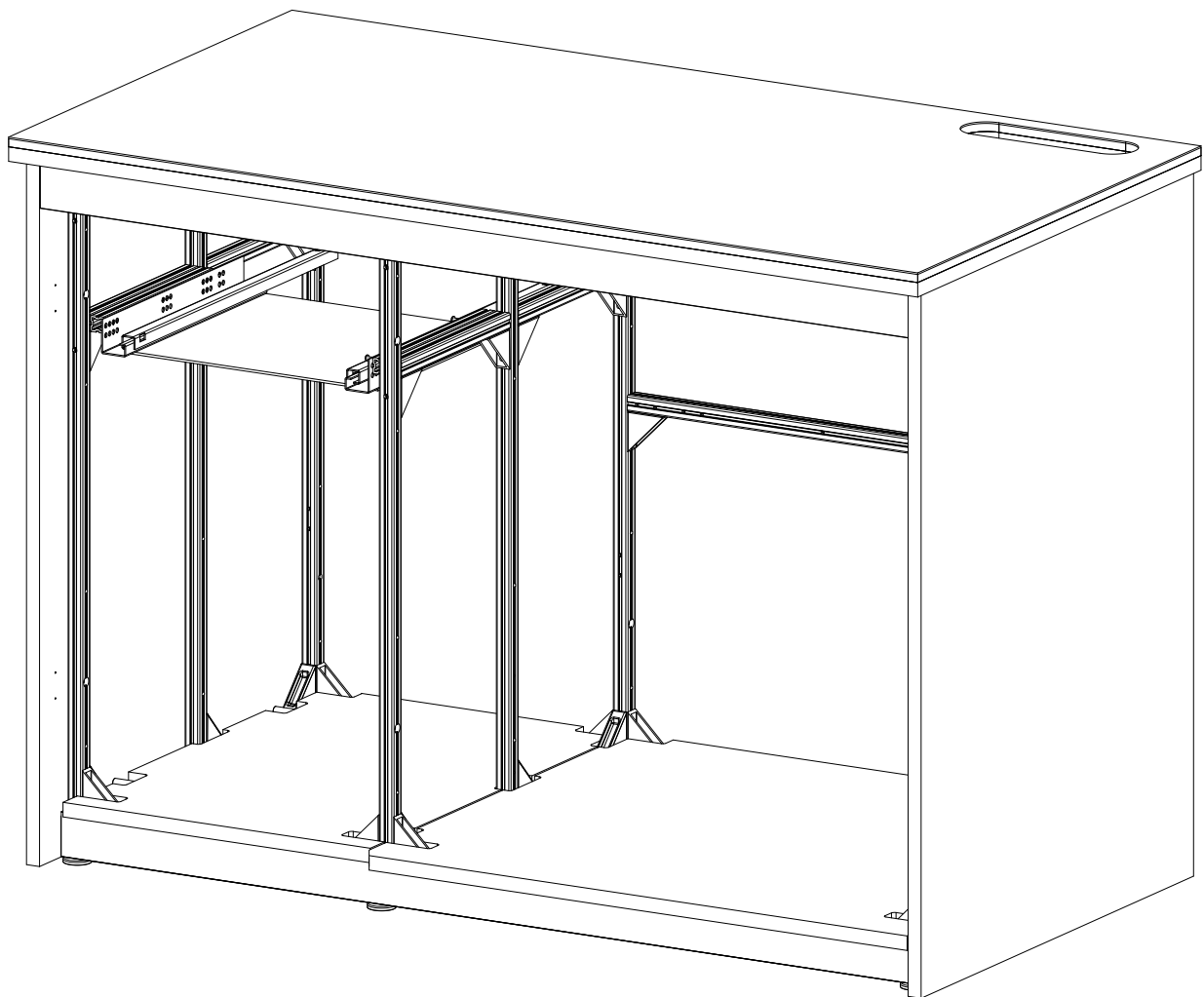

Parts | Teile | Éléments | 部件

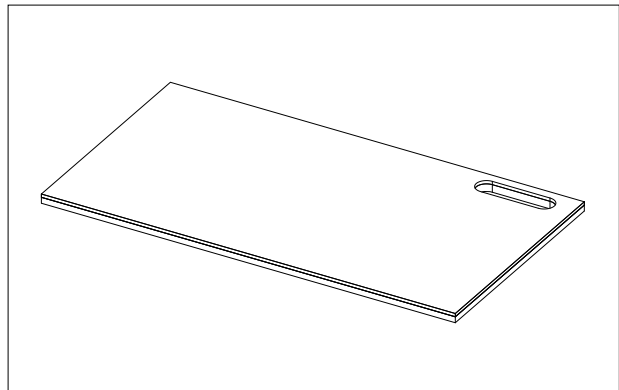
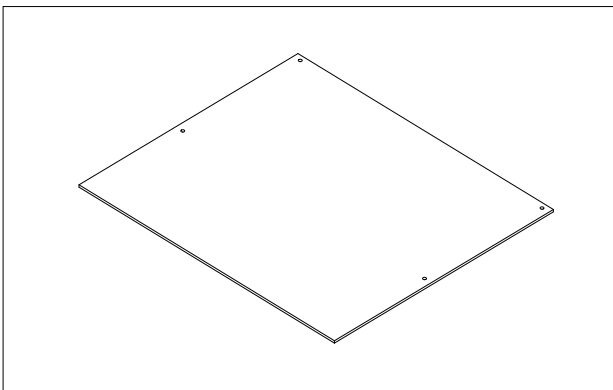
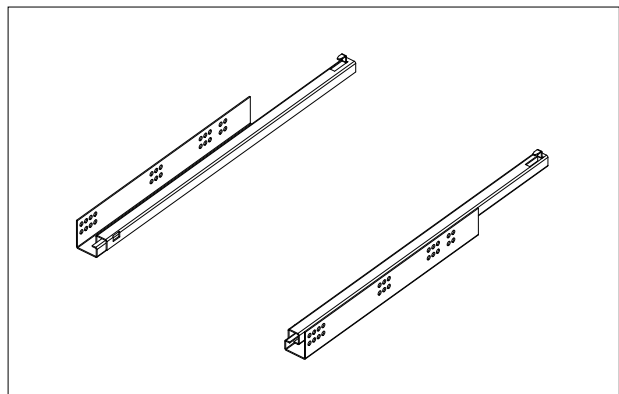
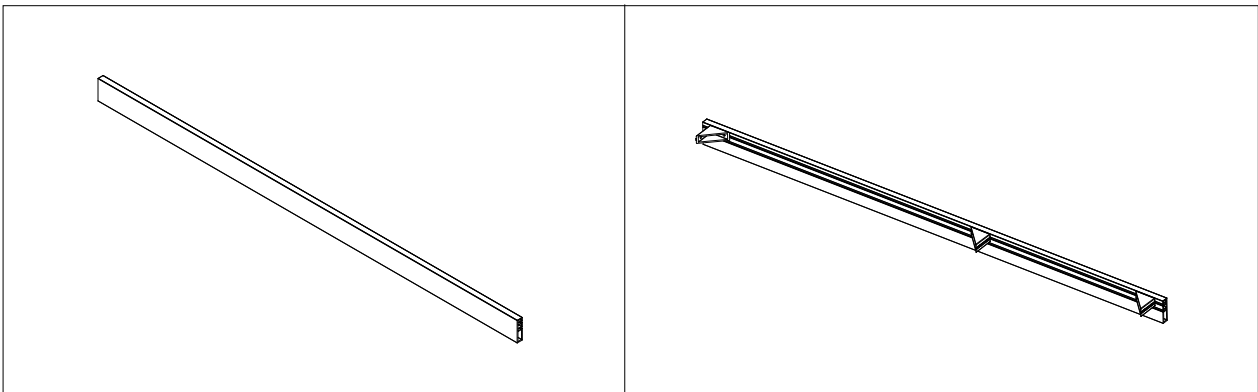
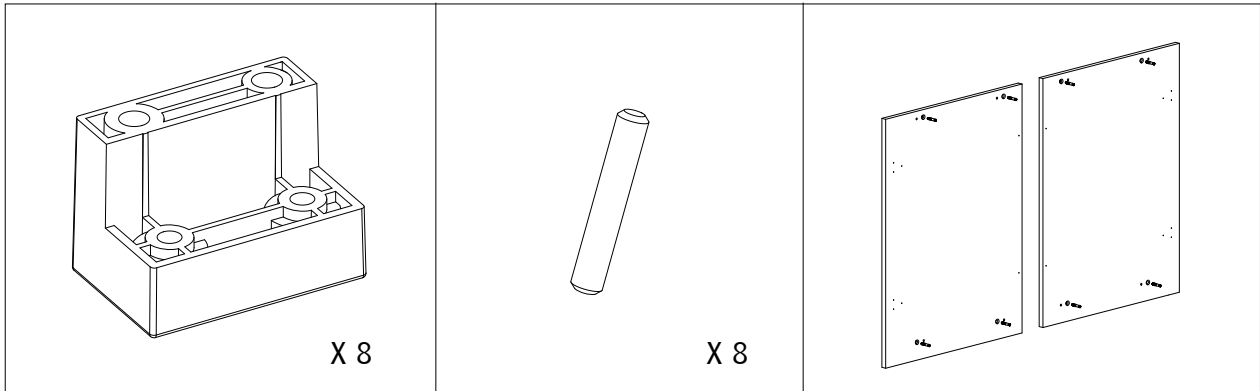

1.

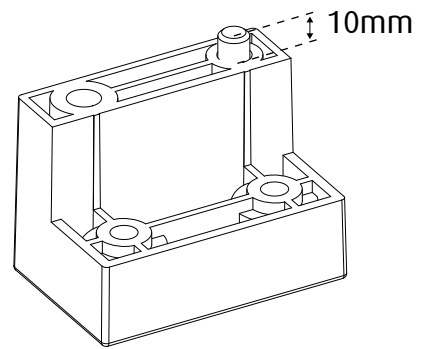
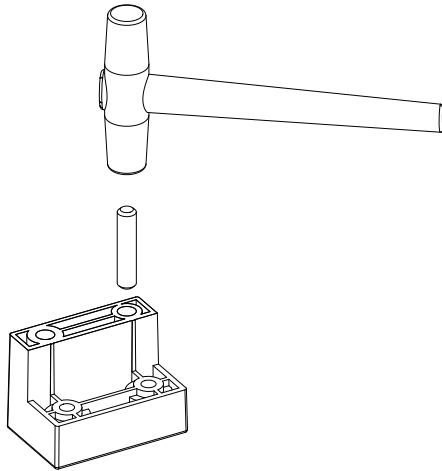

X 8

2.

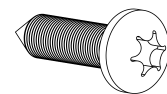
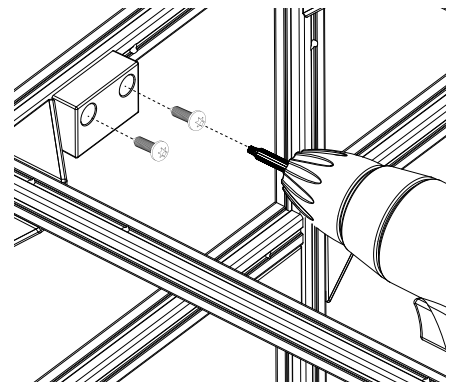
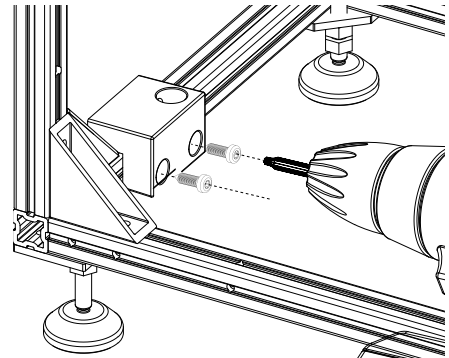
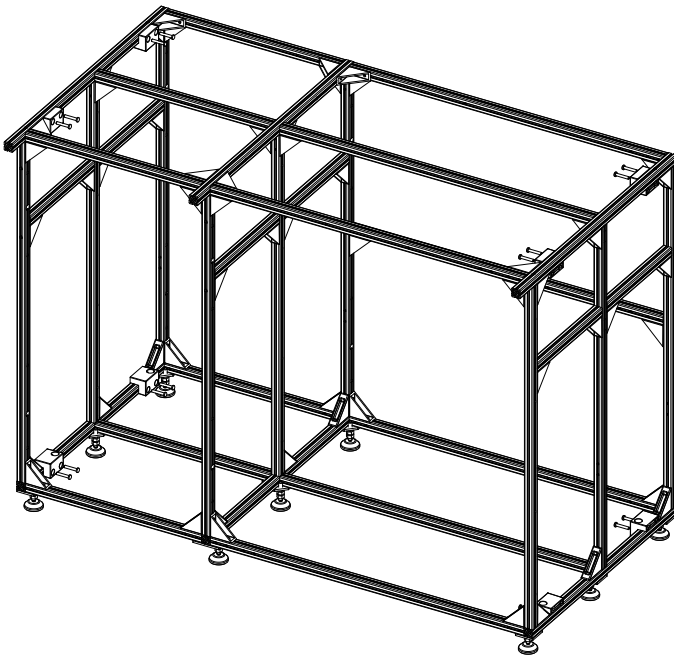

S1 X16

3.

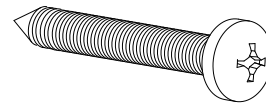
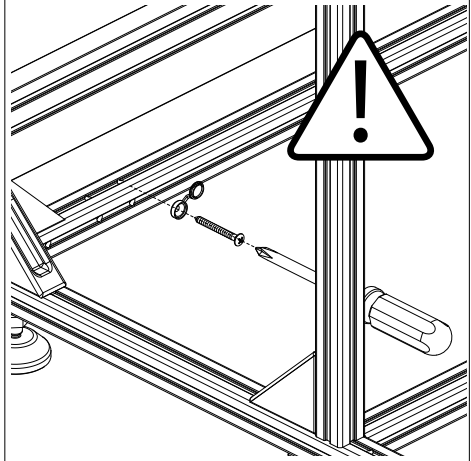
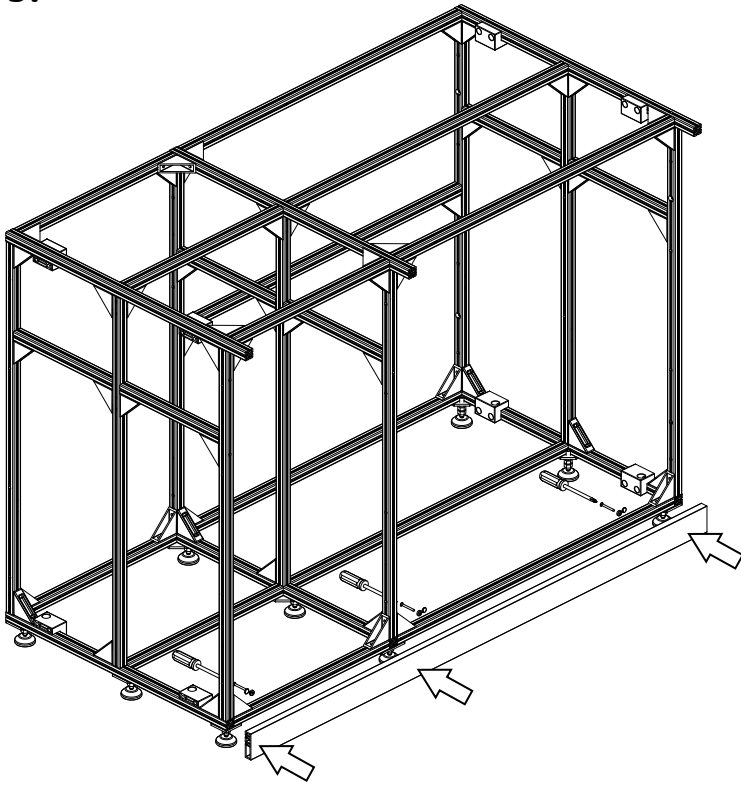

S8 X 3

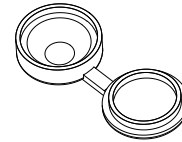

X 3

4.

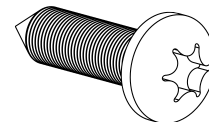
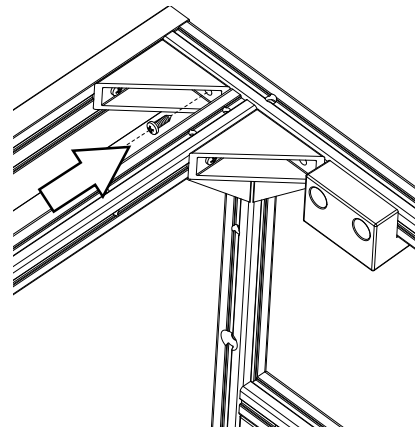
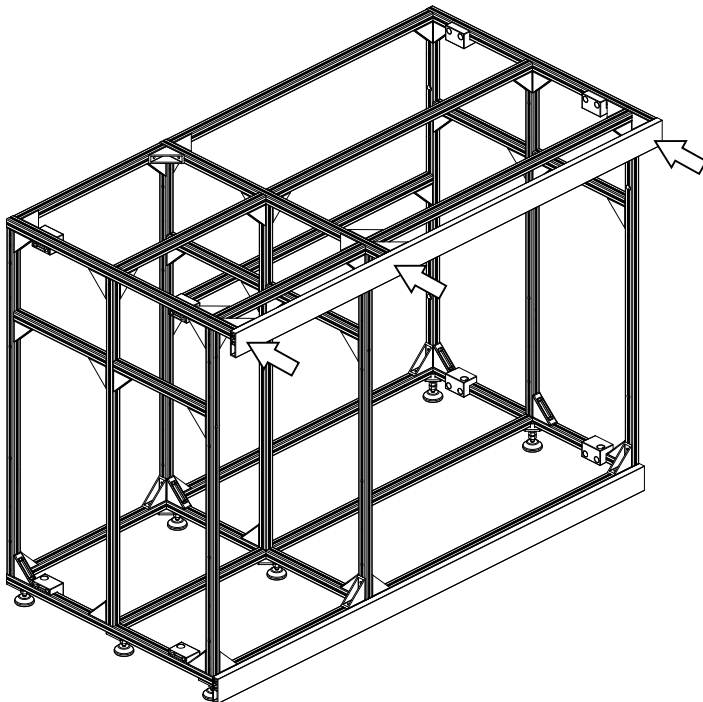
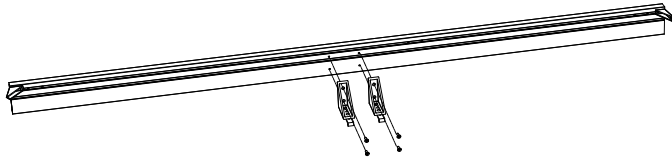

S1 X 3

5.

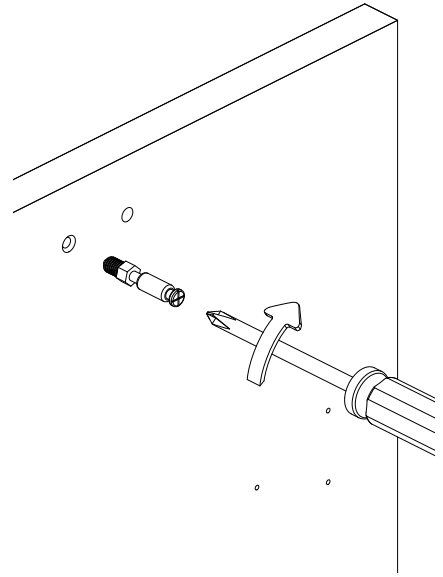
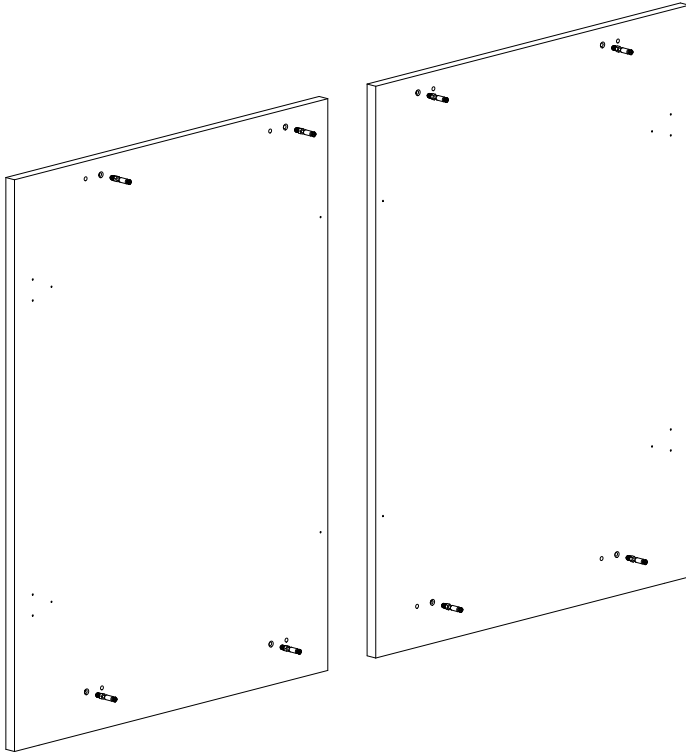

X 8

6.

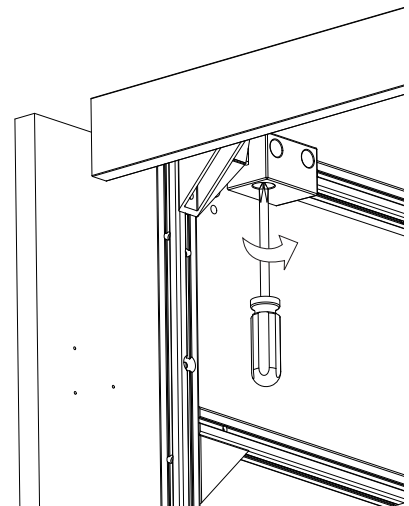
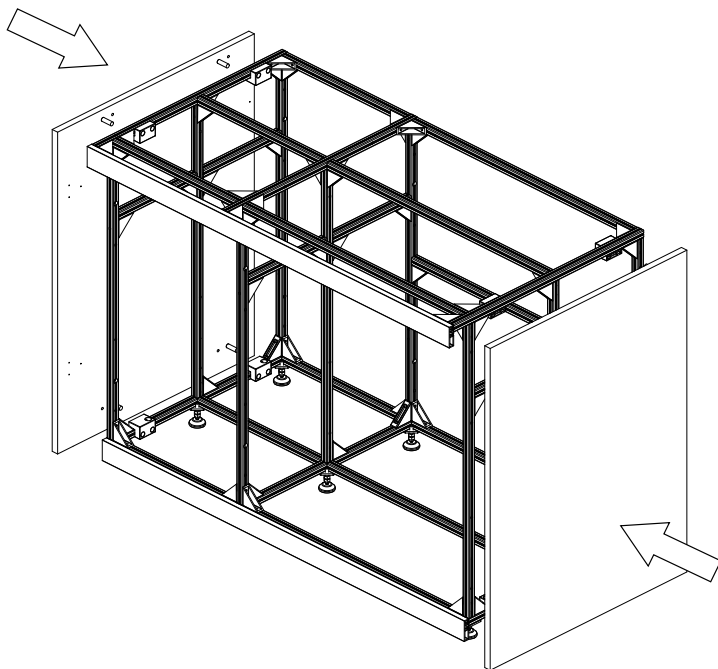

X 8

7.

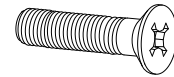
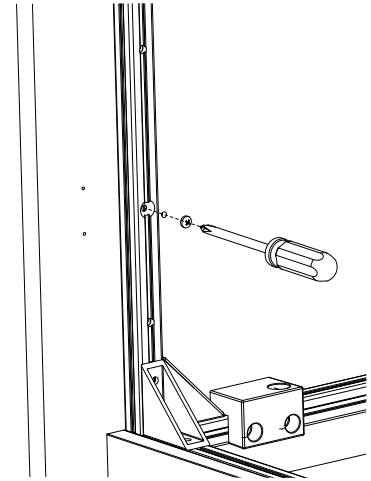
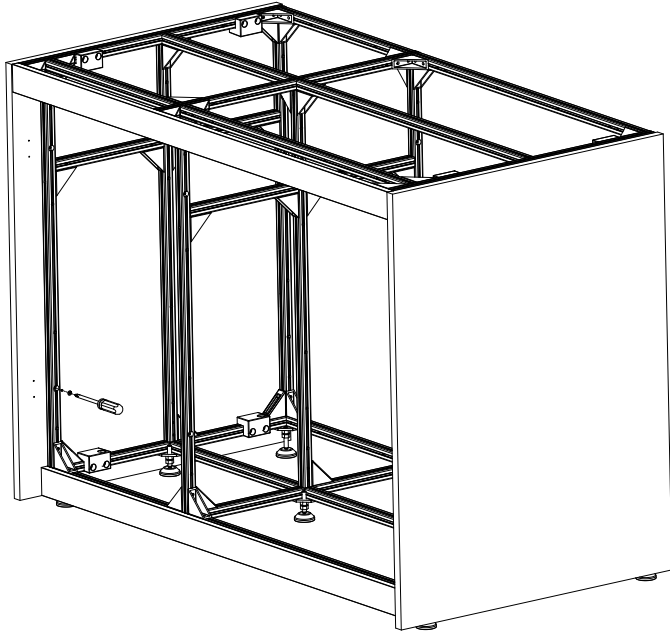

S4 X 8

8.

MAX® S-400

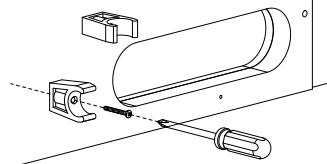

MAX® S-500

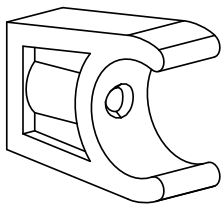
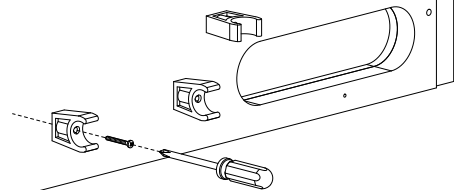

X2

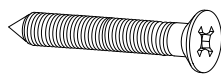

S3 X 2

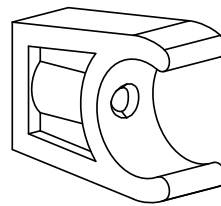

X3

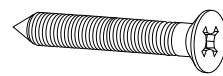

S3 X 3

9.

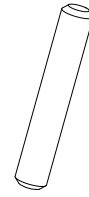
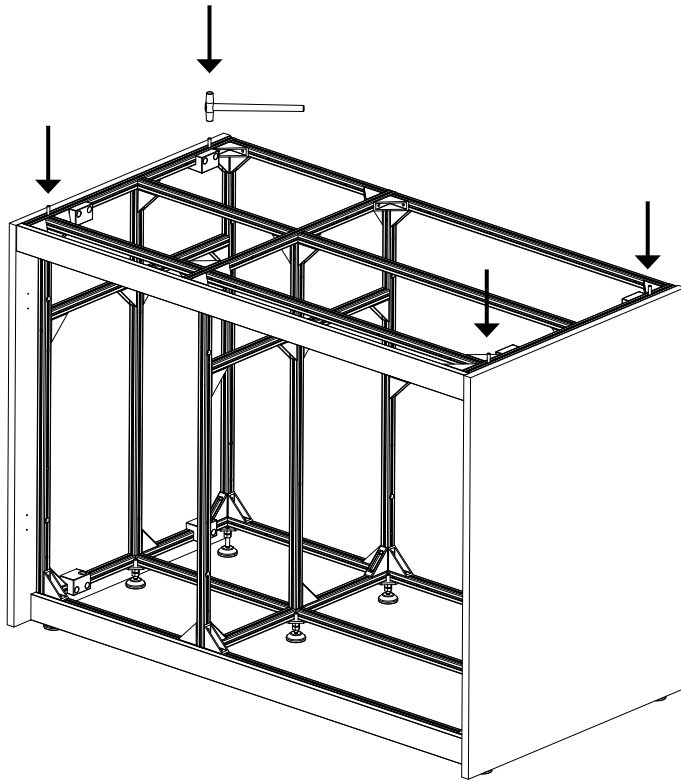

X 4

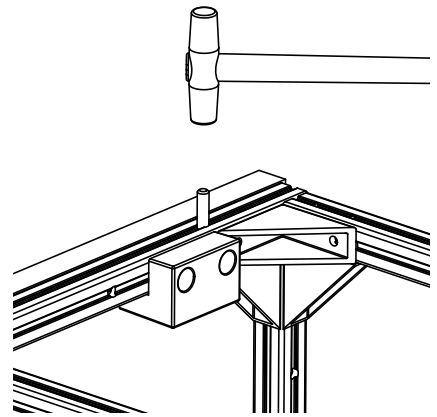

10.

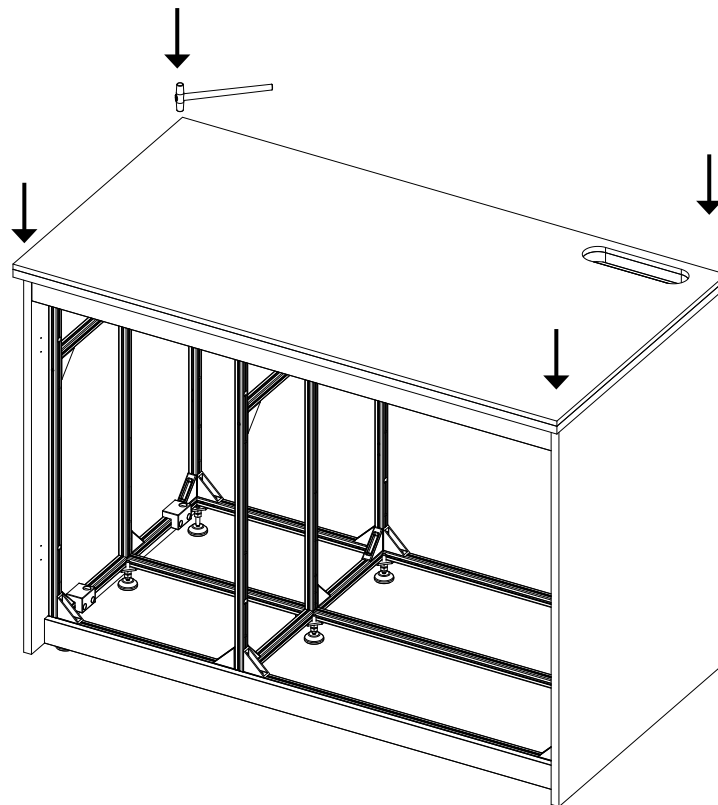

11.

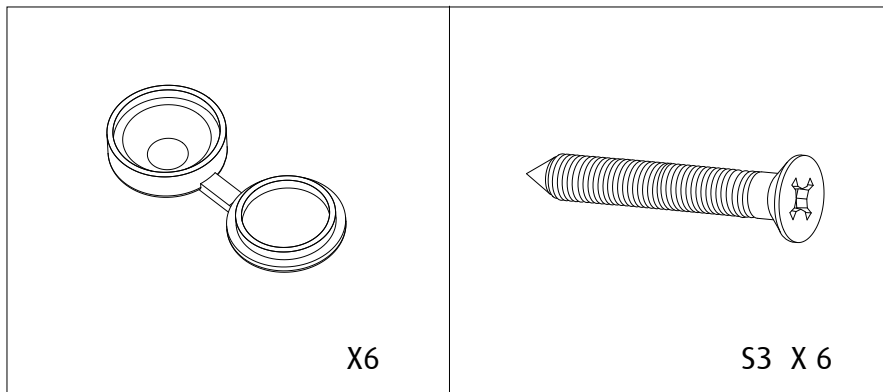
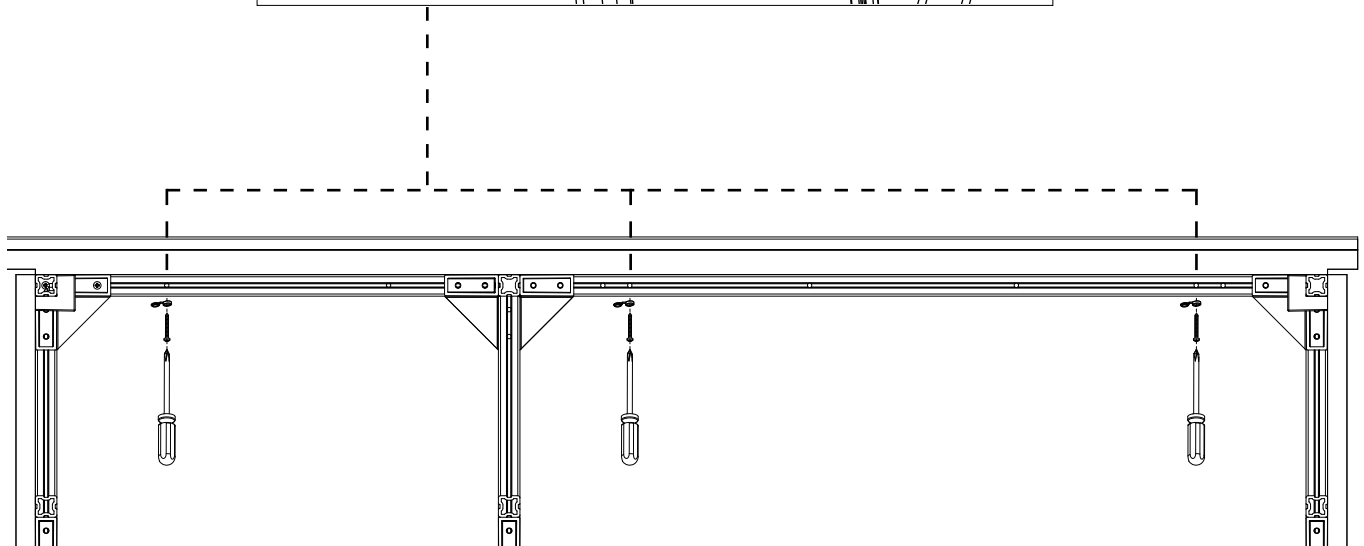
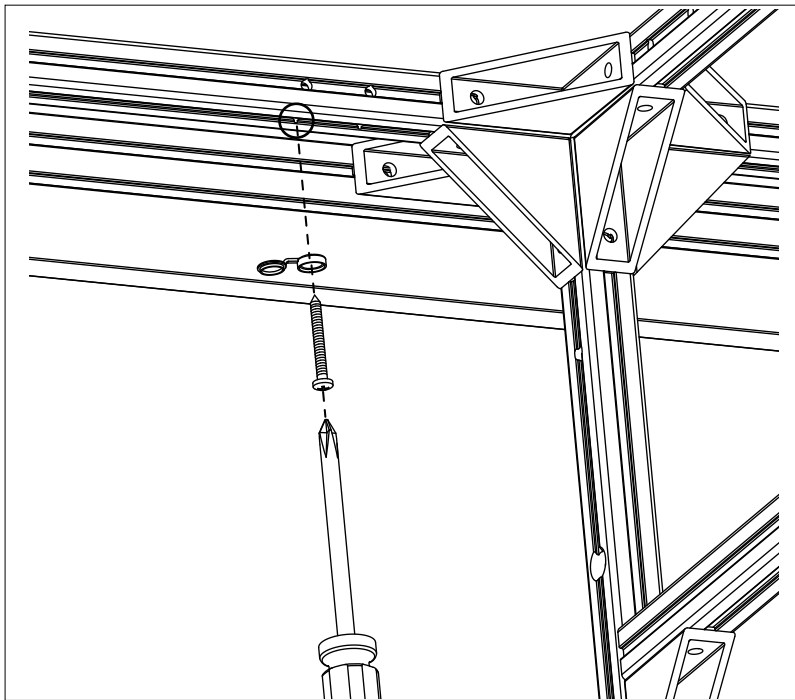

MAX® S-400

12.

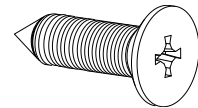
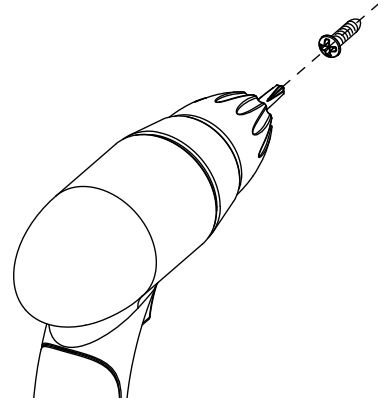
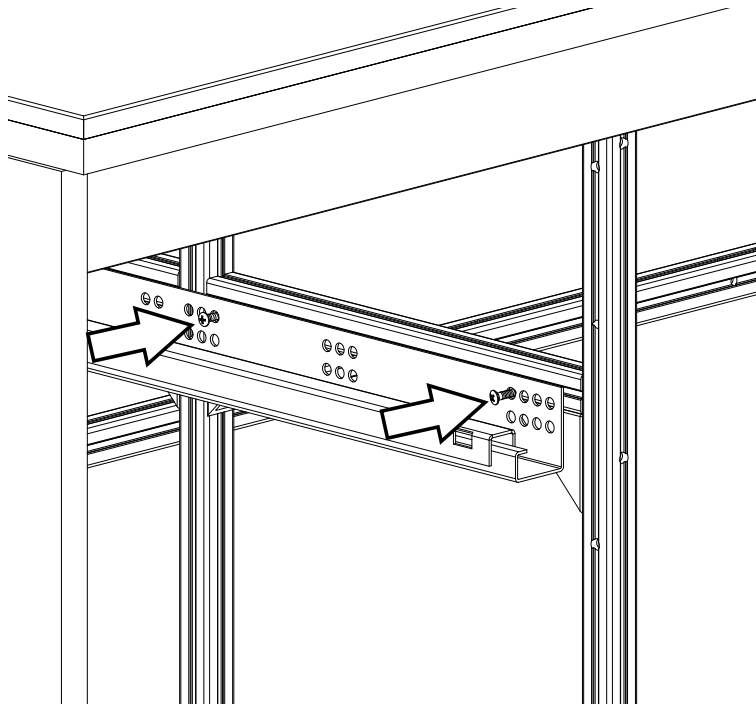

S2 X 2

13.

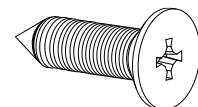
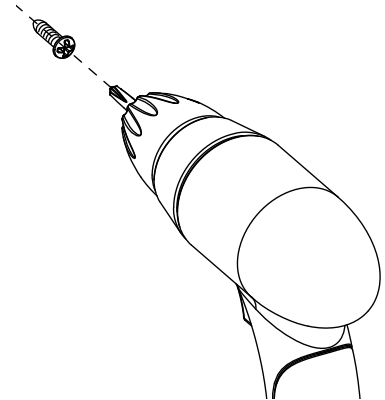
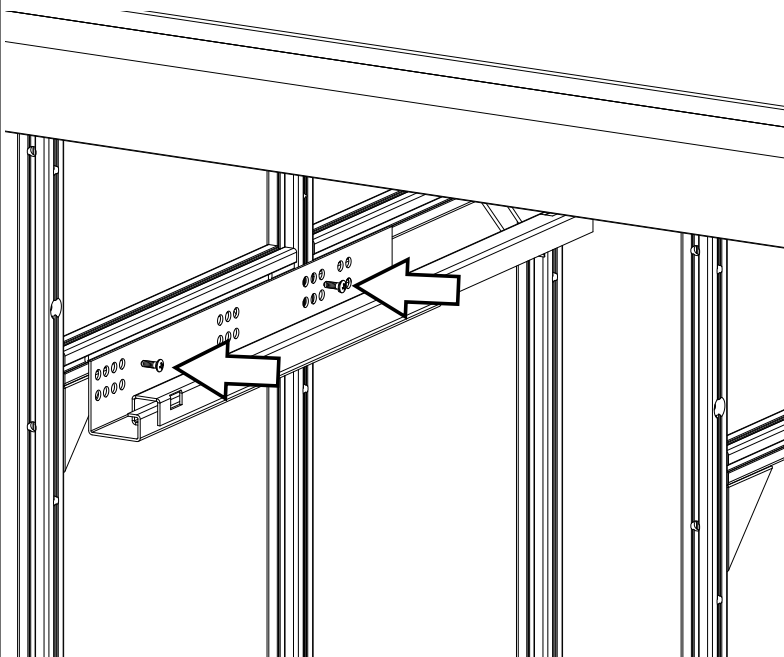

S2 X 2

MAX® S-500

12.

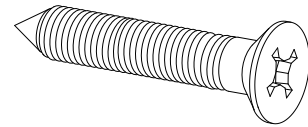
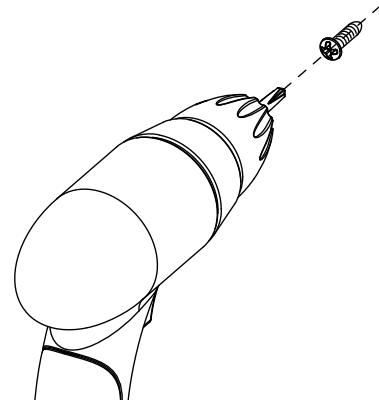
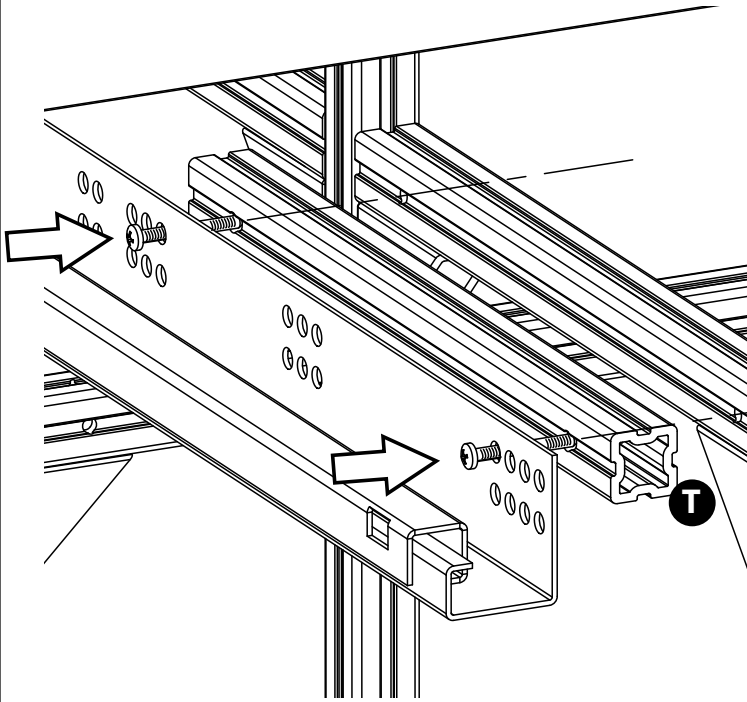

S7 X 2

13.

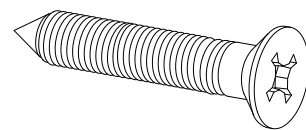
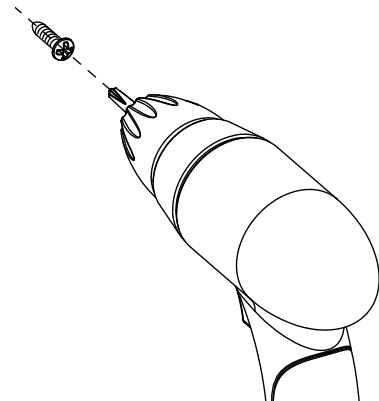
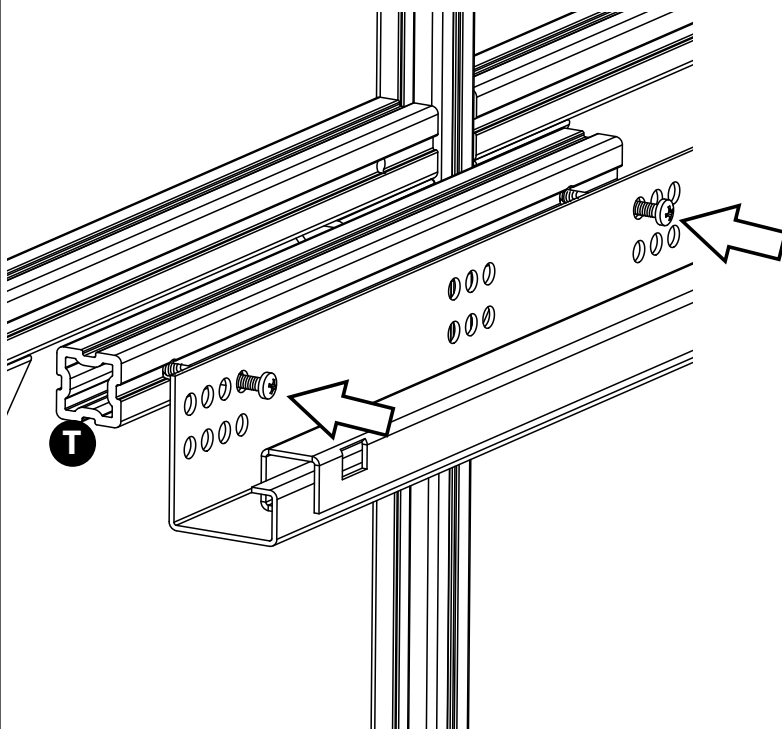

S7 X 2

14.

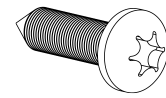
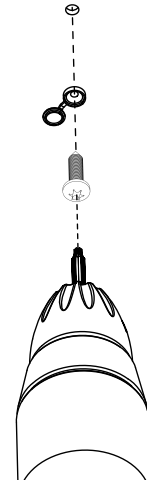
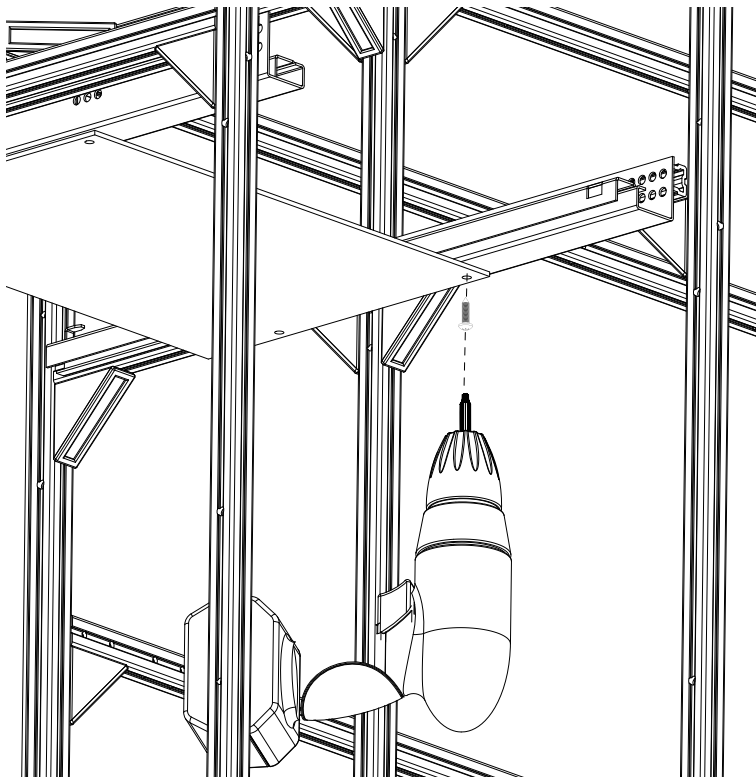

S1 X 4

15.

MAX® S-500

Only | Nur | uniquement | 只限于

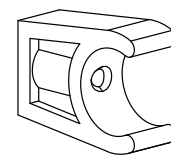
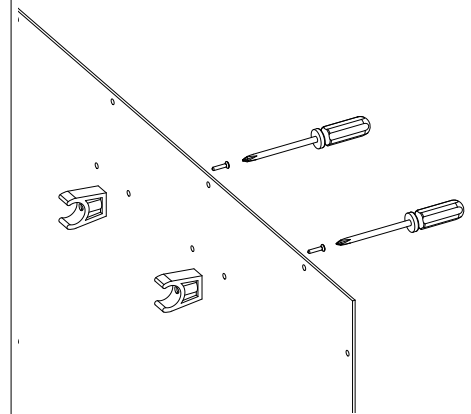
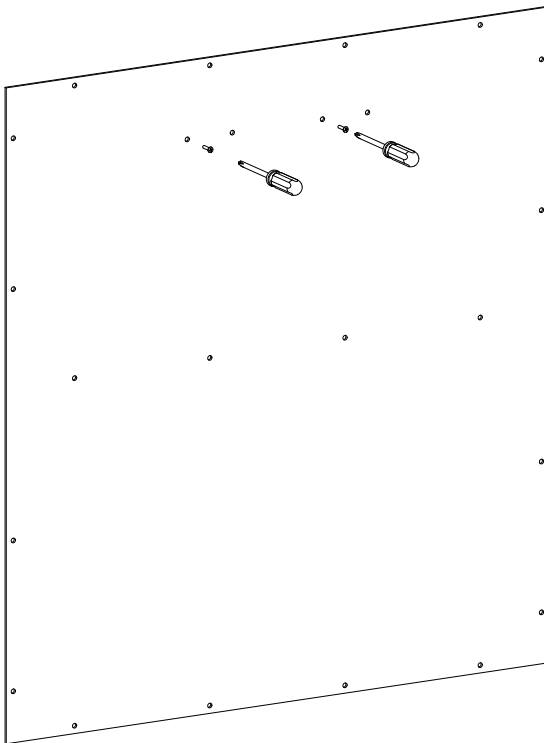

X 2

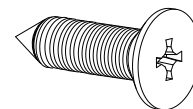

S5 X 2

16.

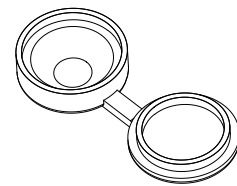
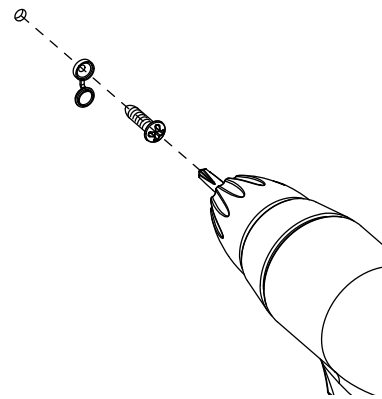
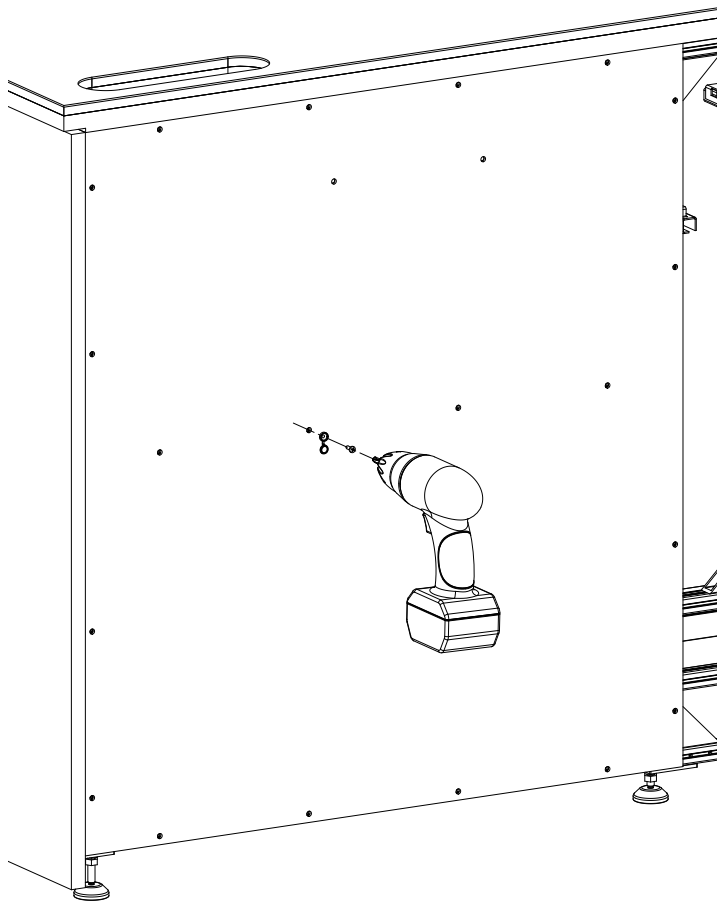

X 20

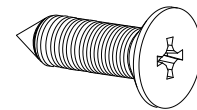

S2 X 20

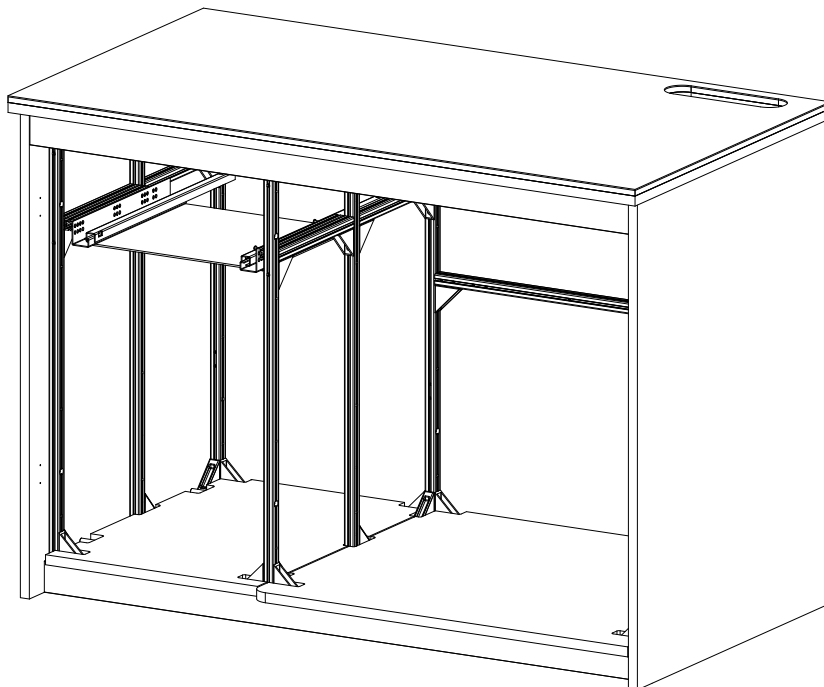

#3

Positioning | Ausrichtung

Emplacement | 擺放位置

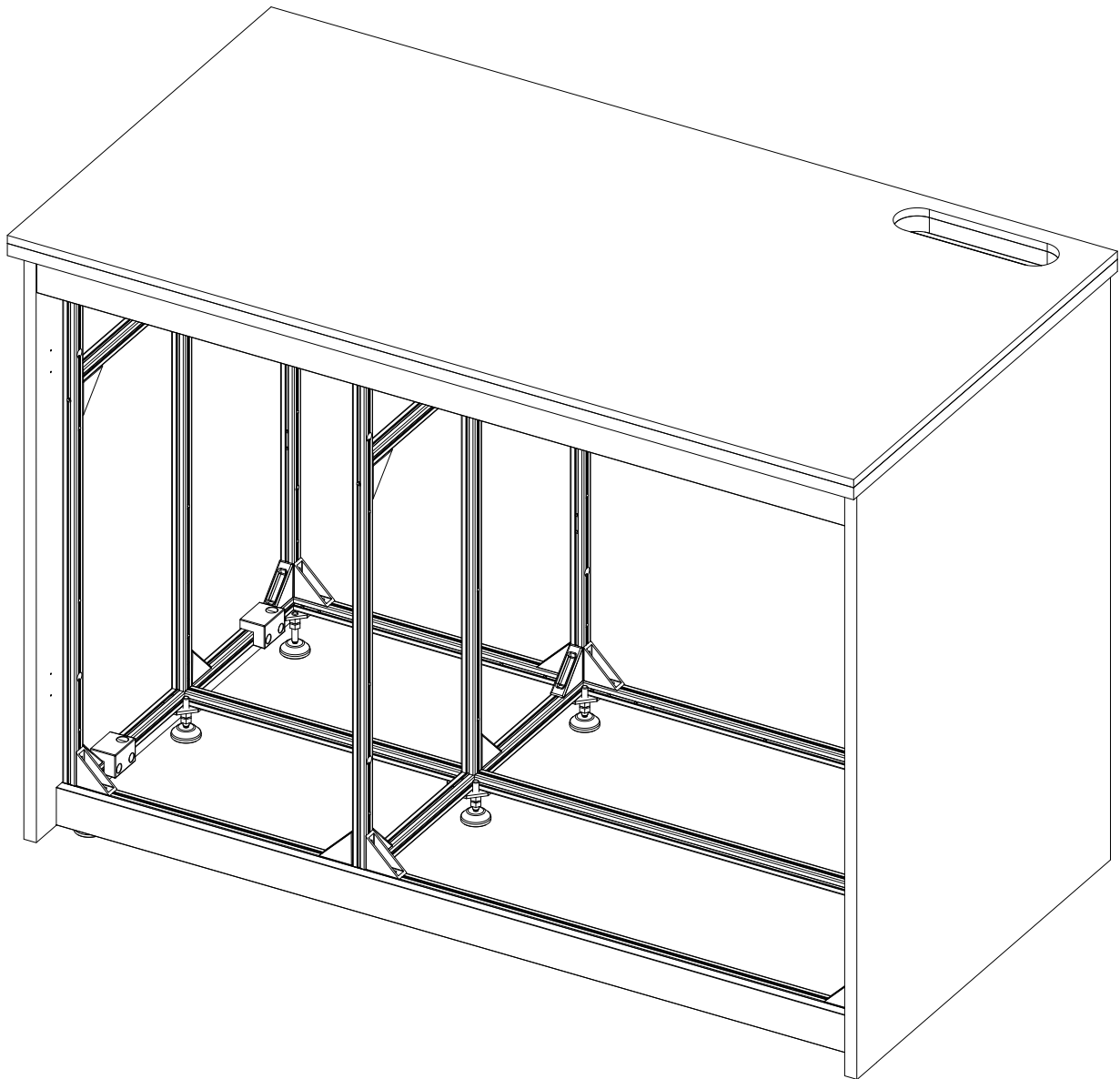

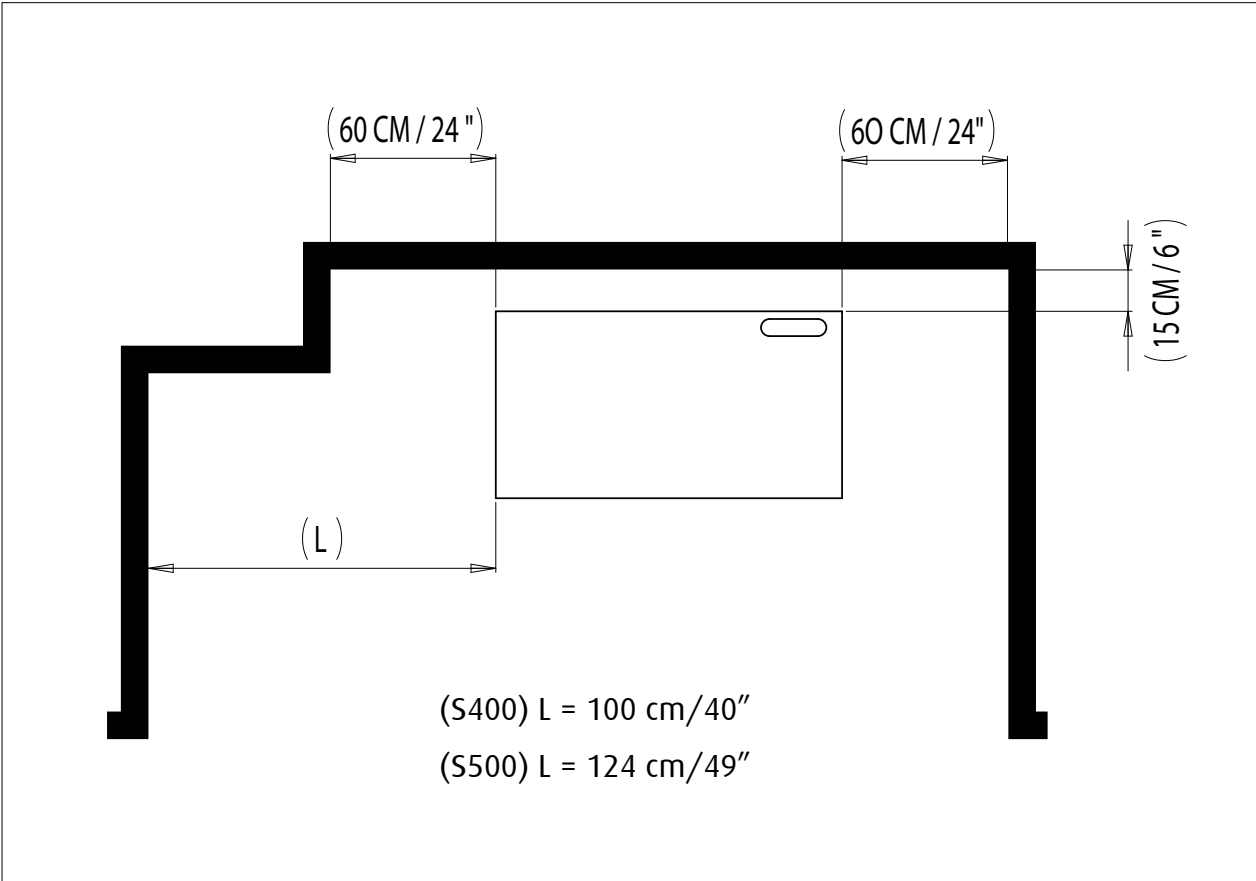
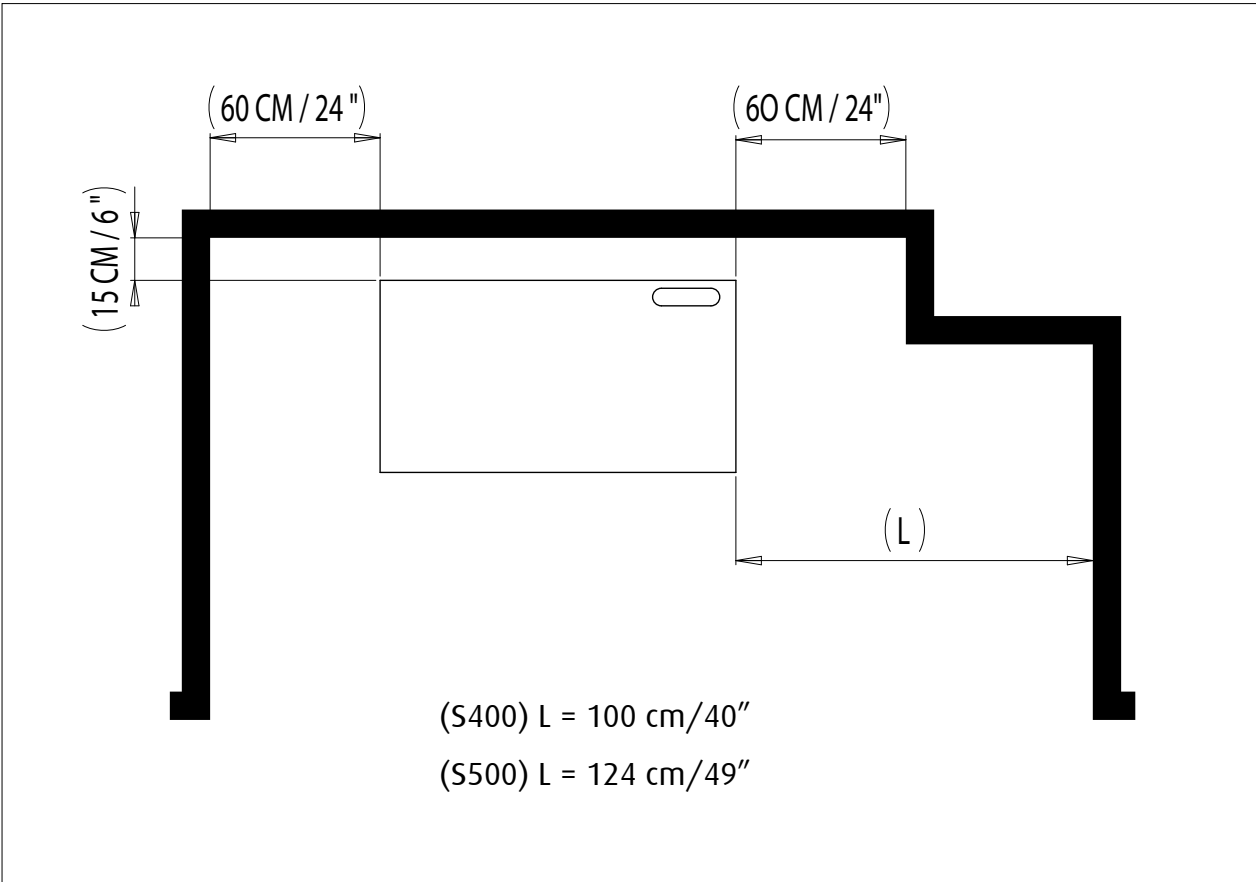

#4

Aquarium & Sump | Aquarium & Filtersumpf
Aquarium et decantation | 水族箱和过滤缸

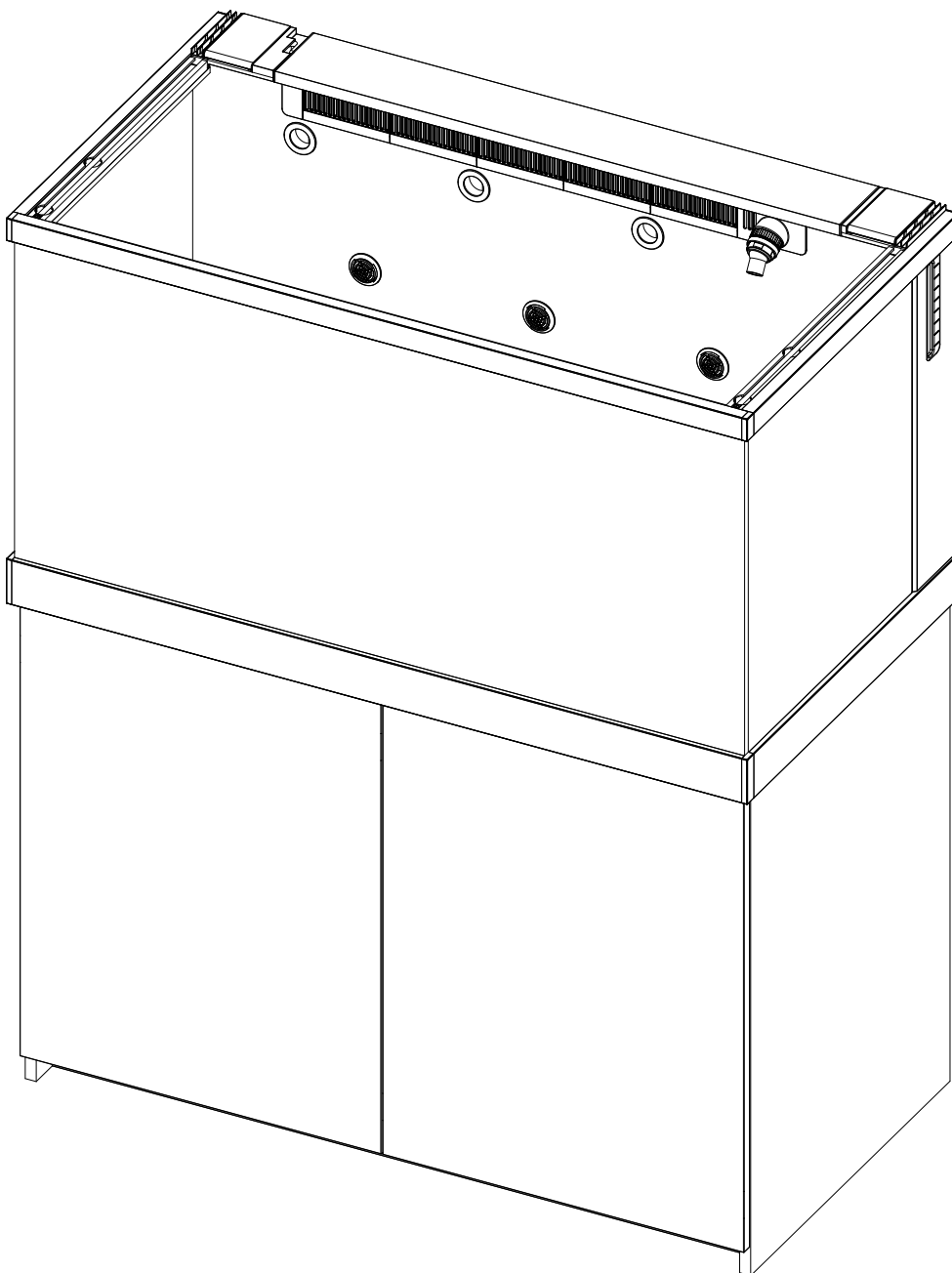

1.

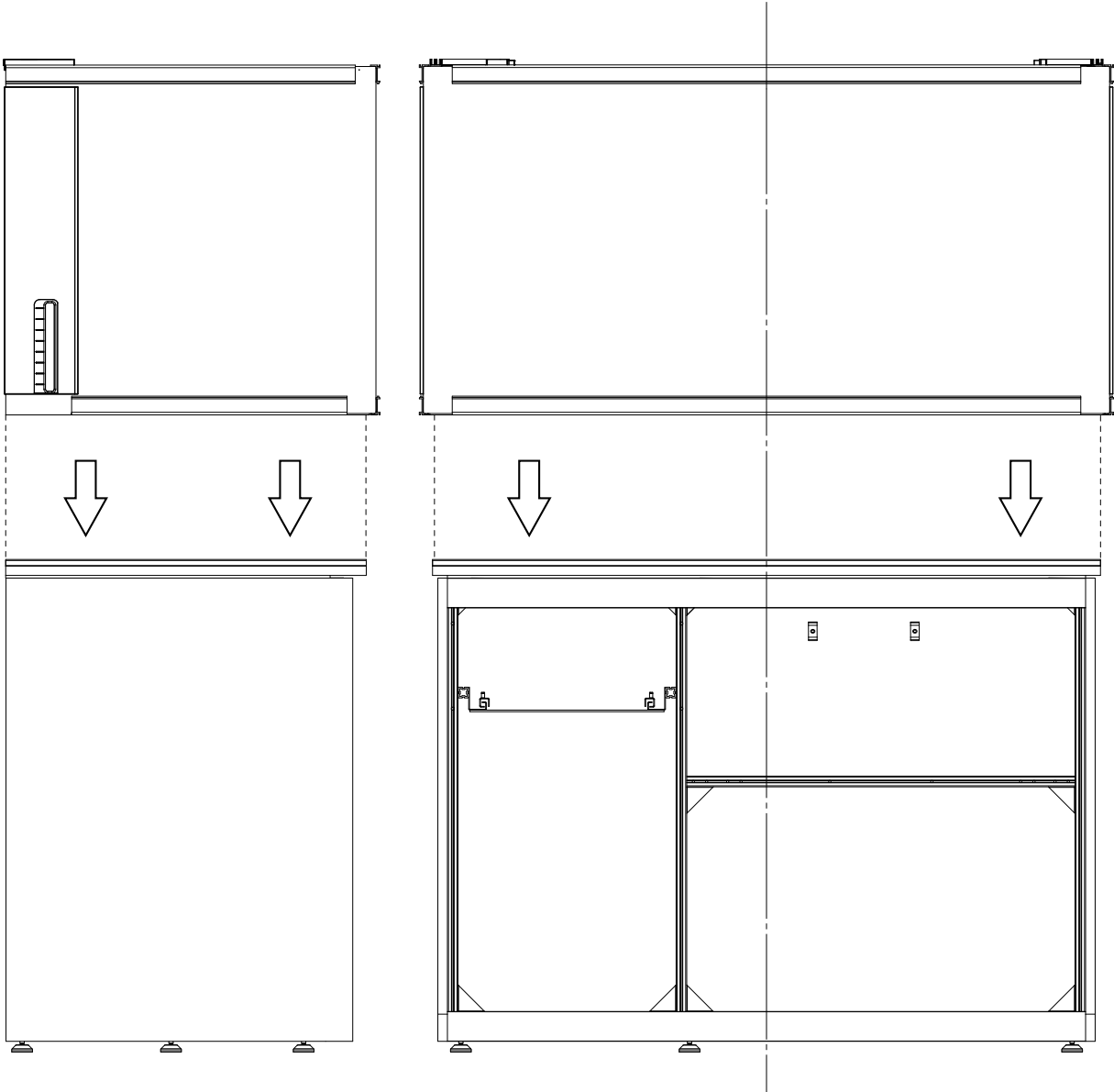

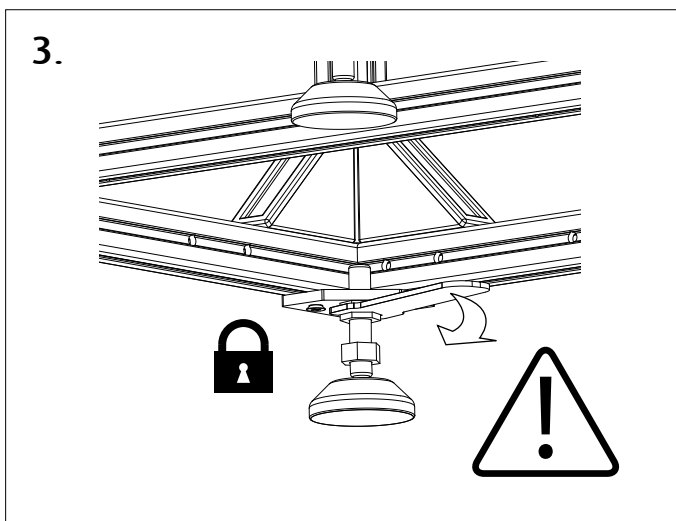
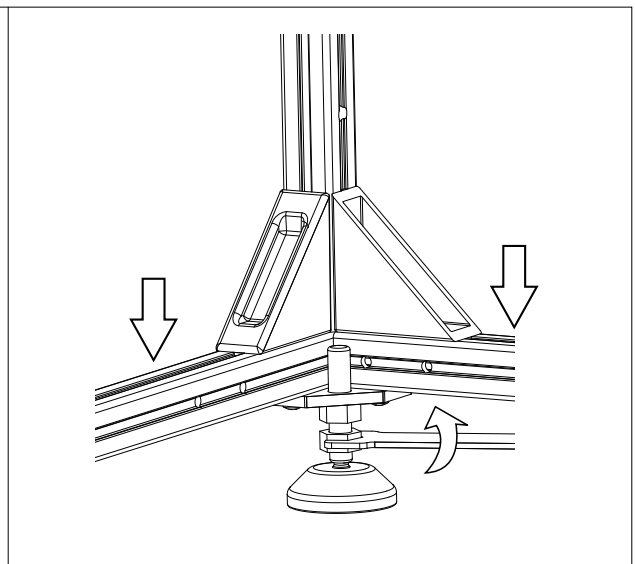
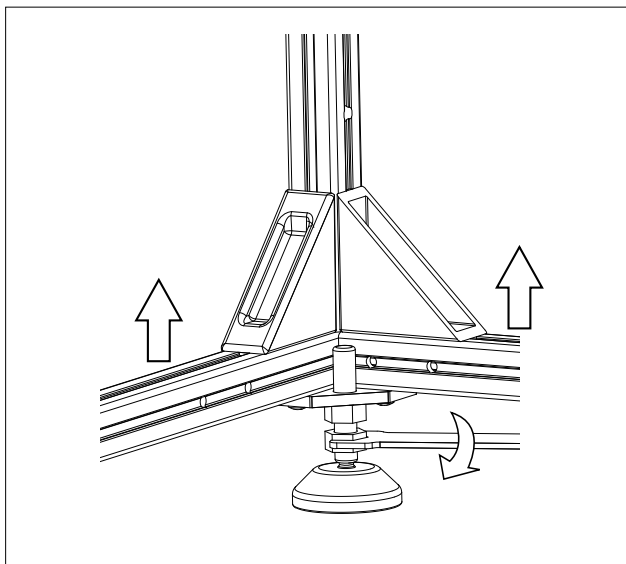
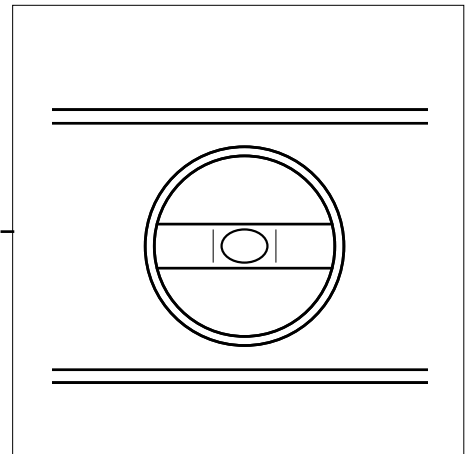
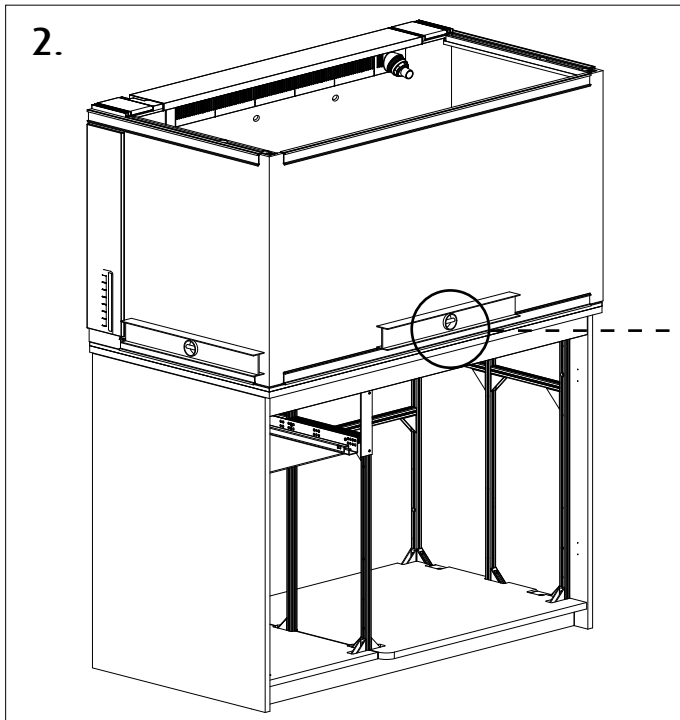

4.

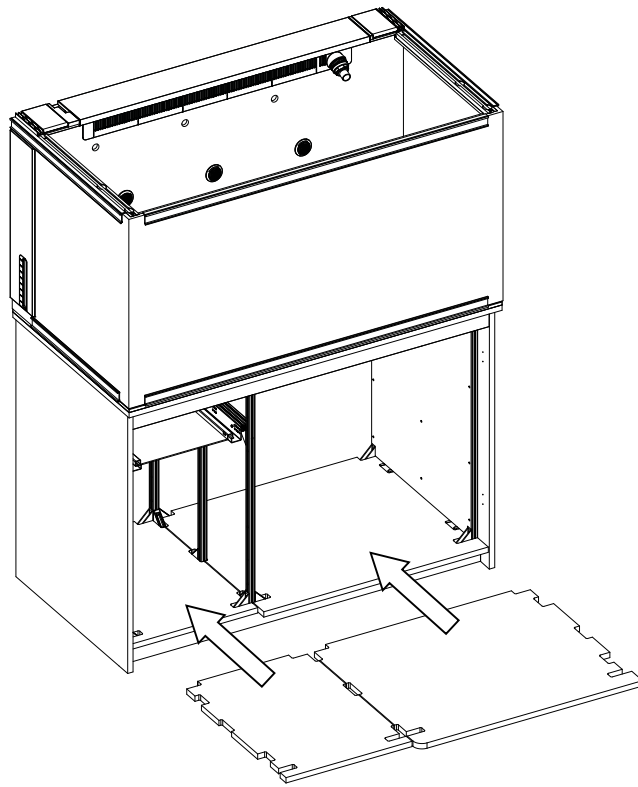

5.

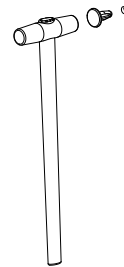
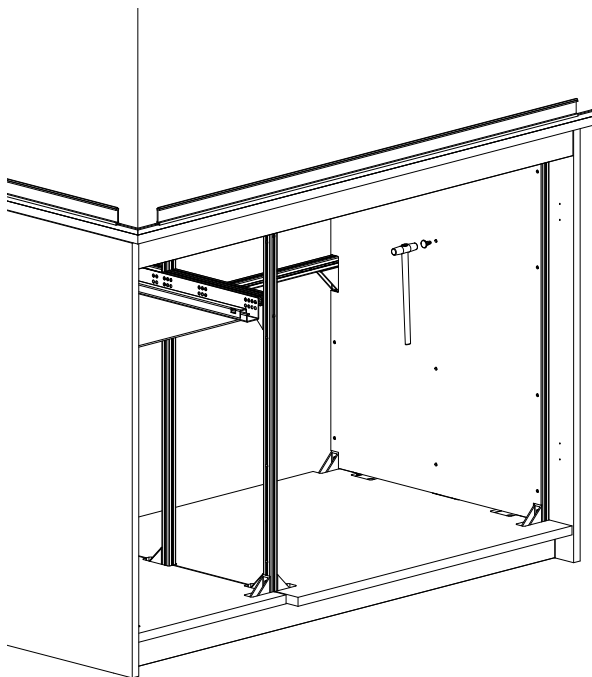

X 14

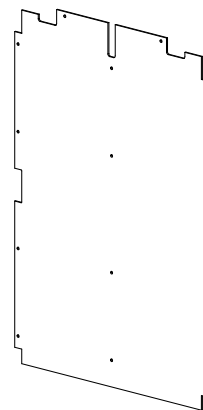

6.

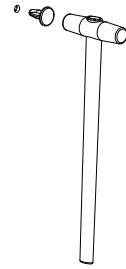
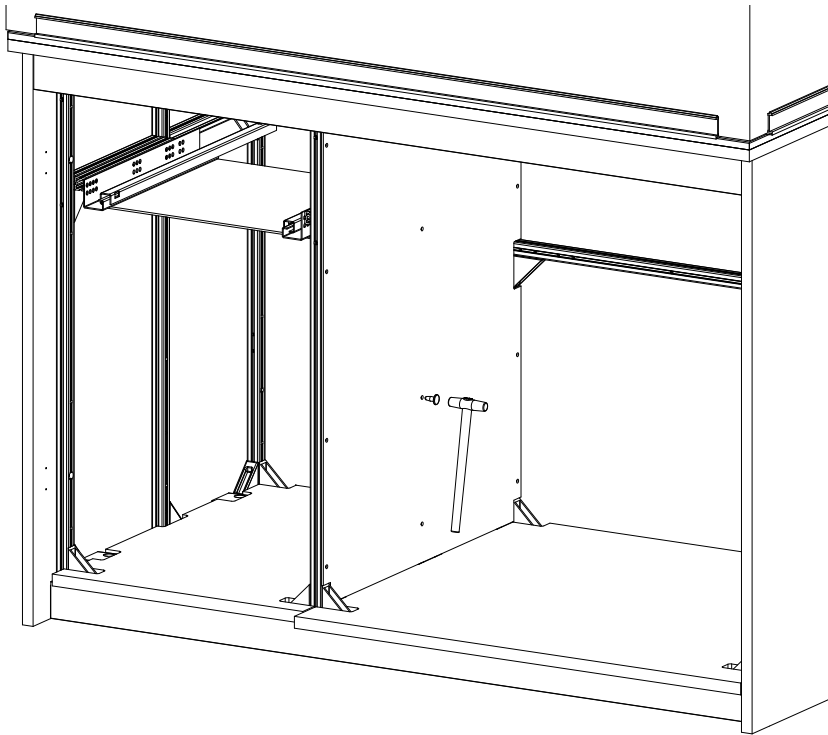

X 13

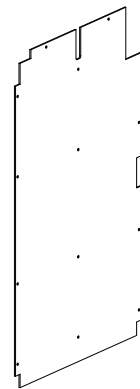

7.

MAX® S-500
Only | Nur | uniquement | 只限于

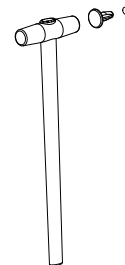
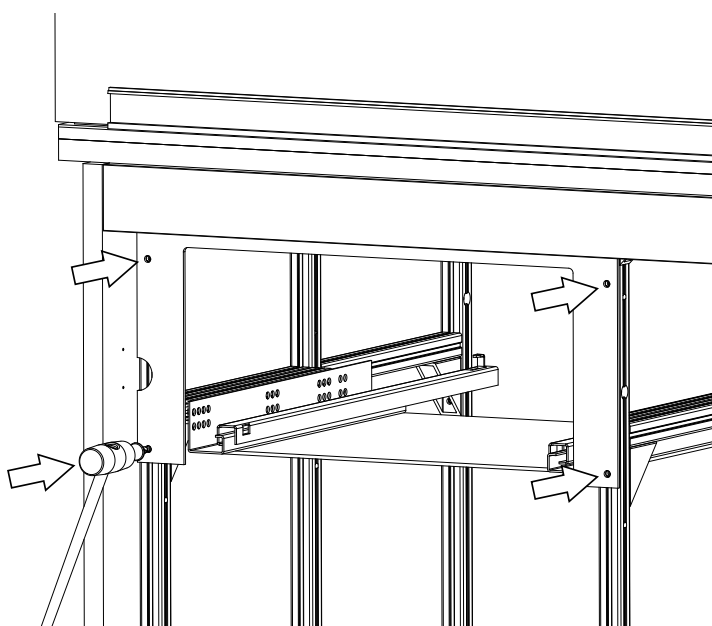

X 4

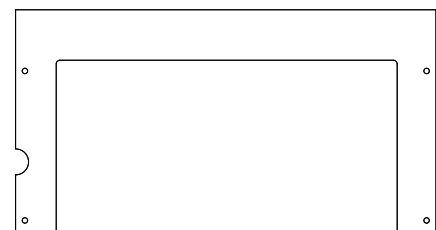

8.

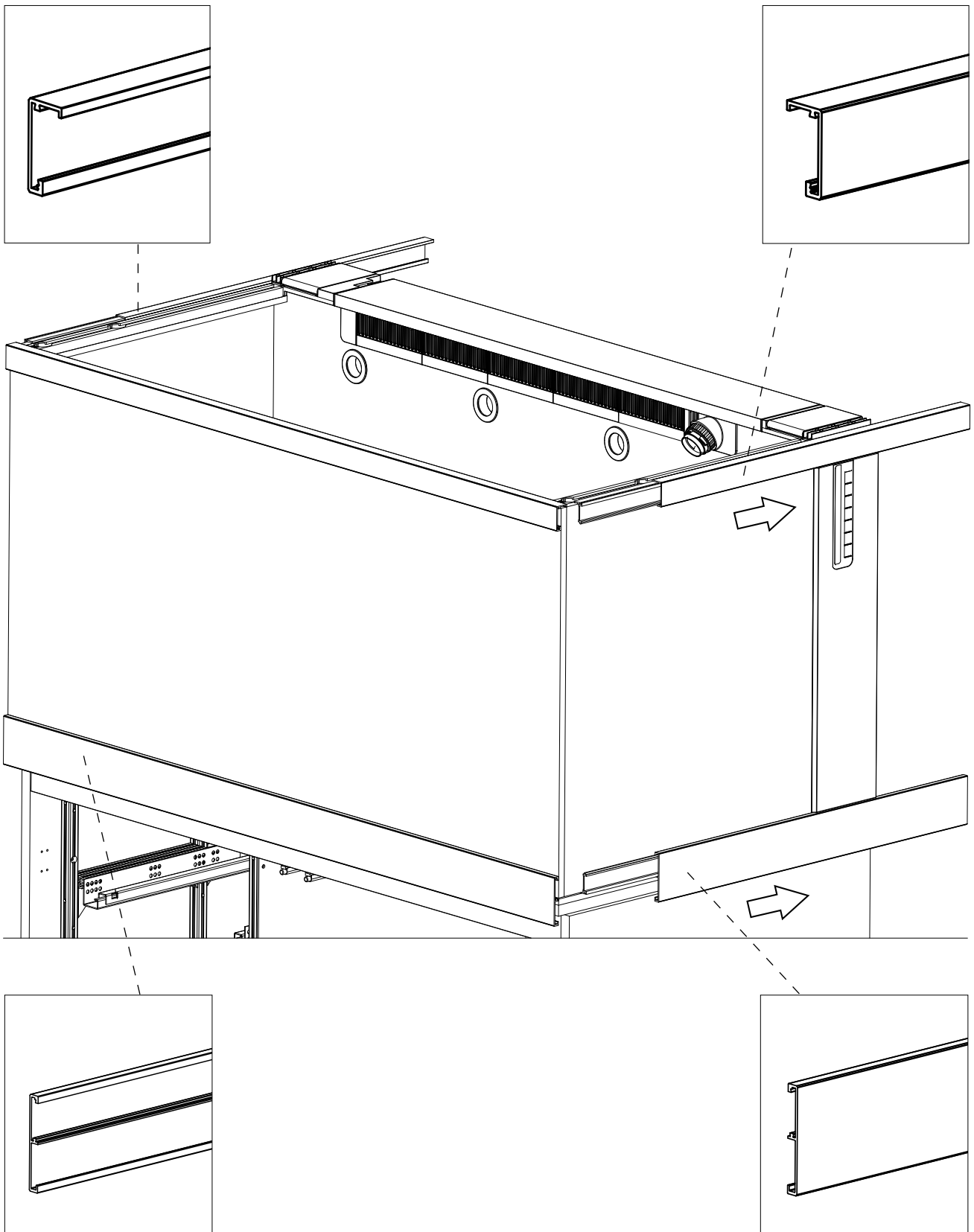

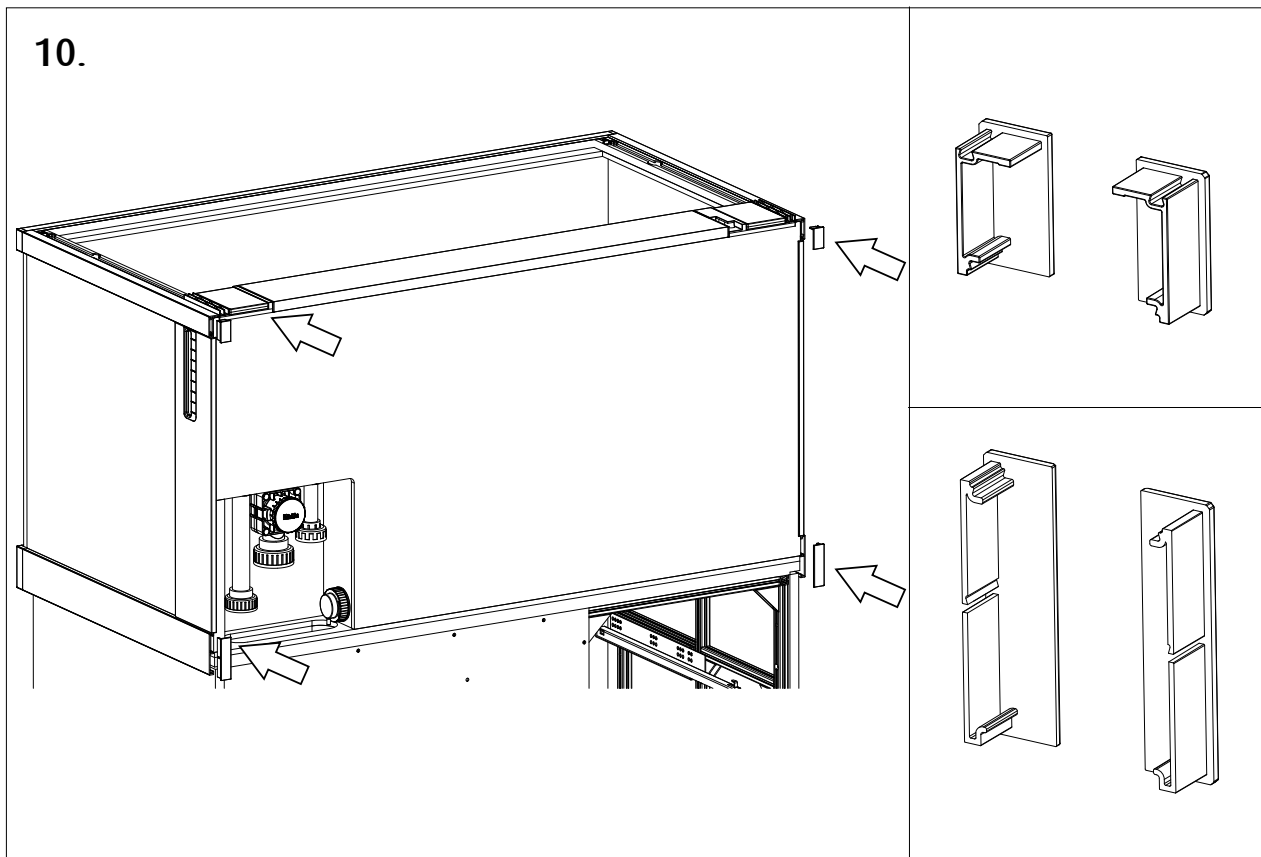
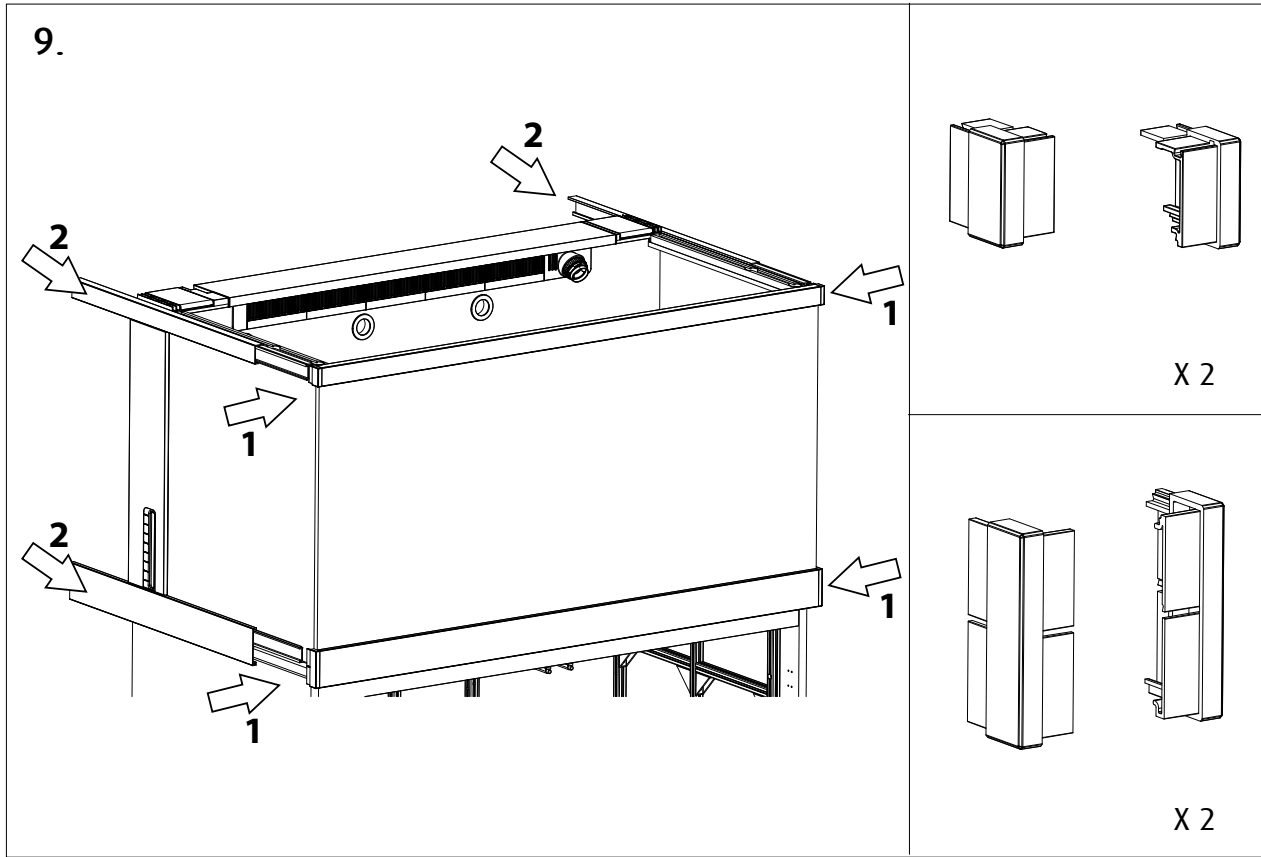

11.

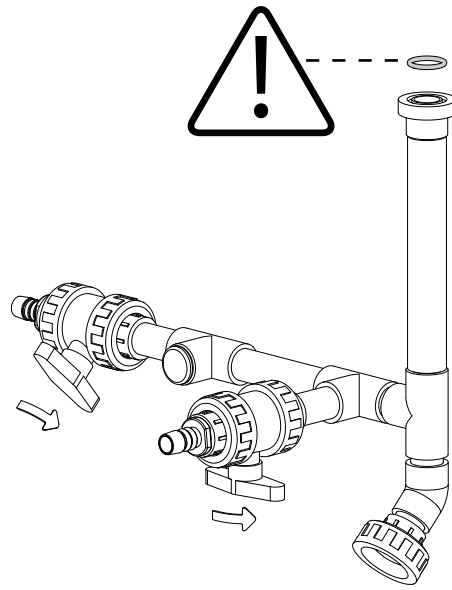
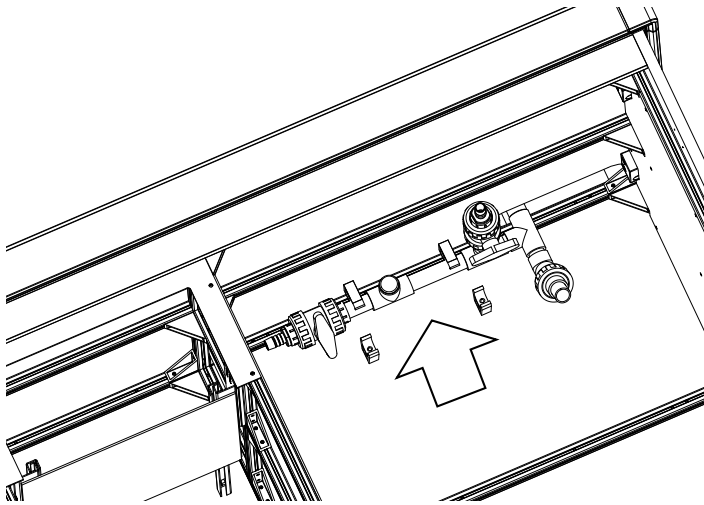

12.

MAX® S-500
Only | Nur | uniquement | 只限于

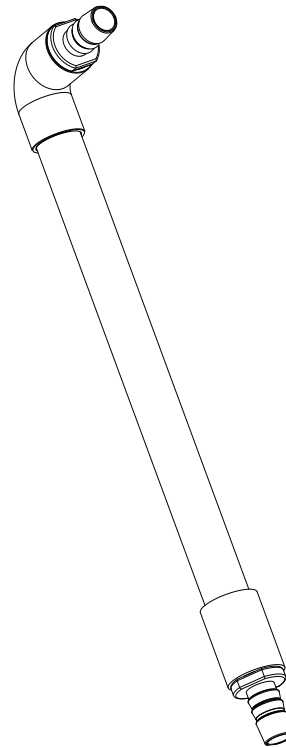
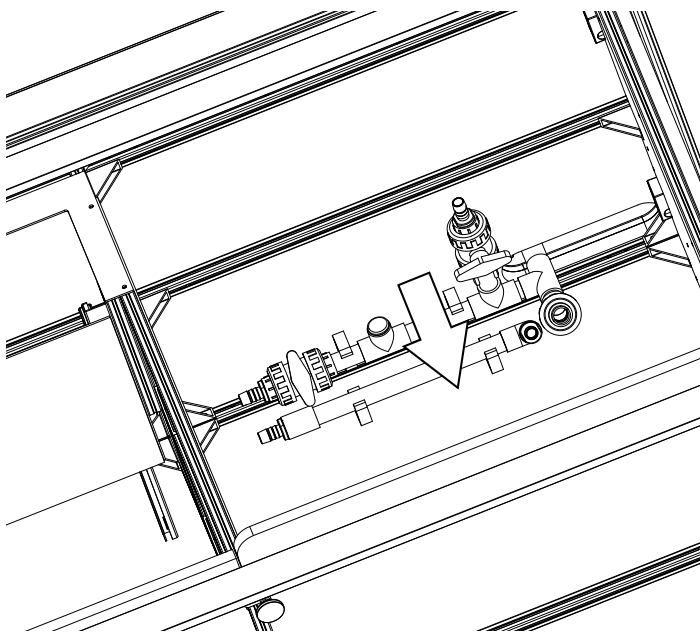

13.

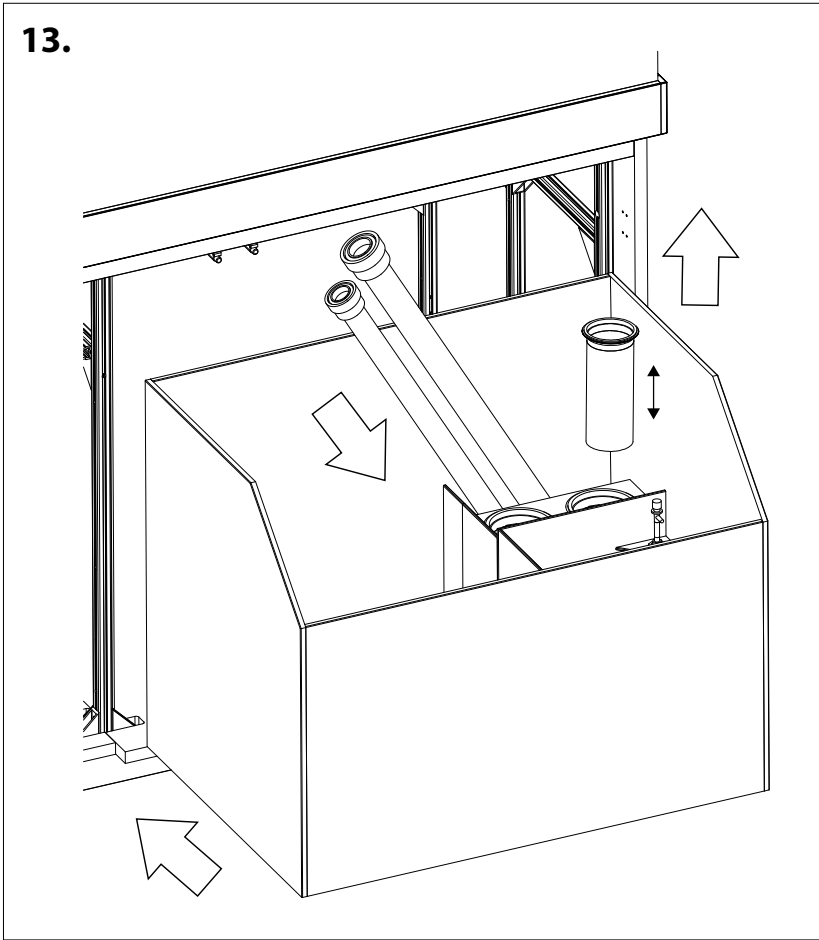

14.

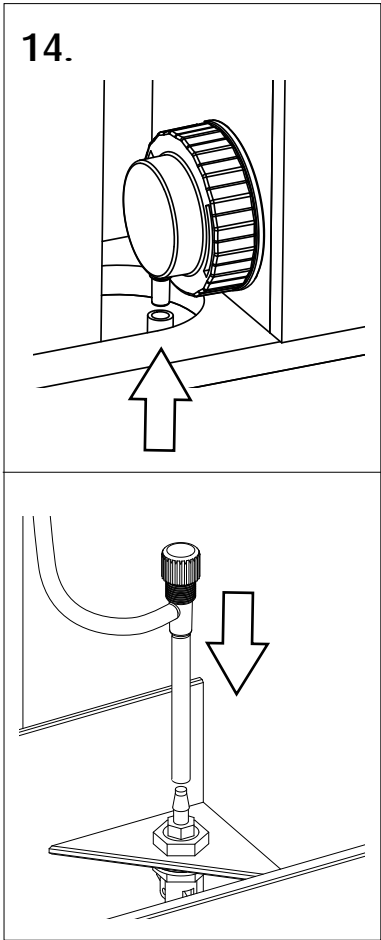

15.

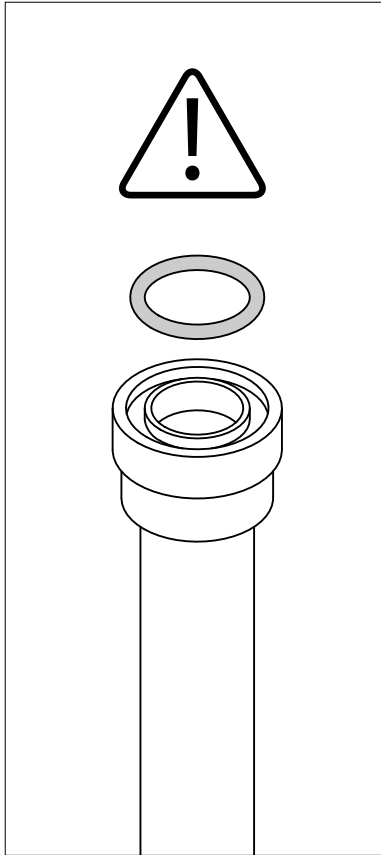
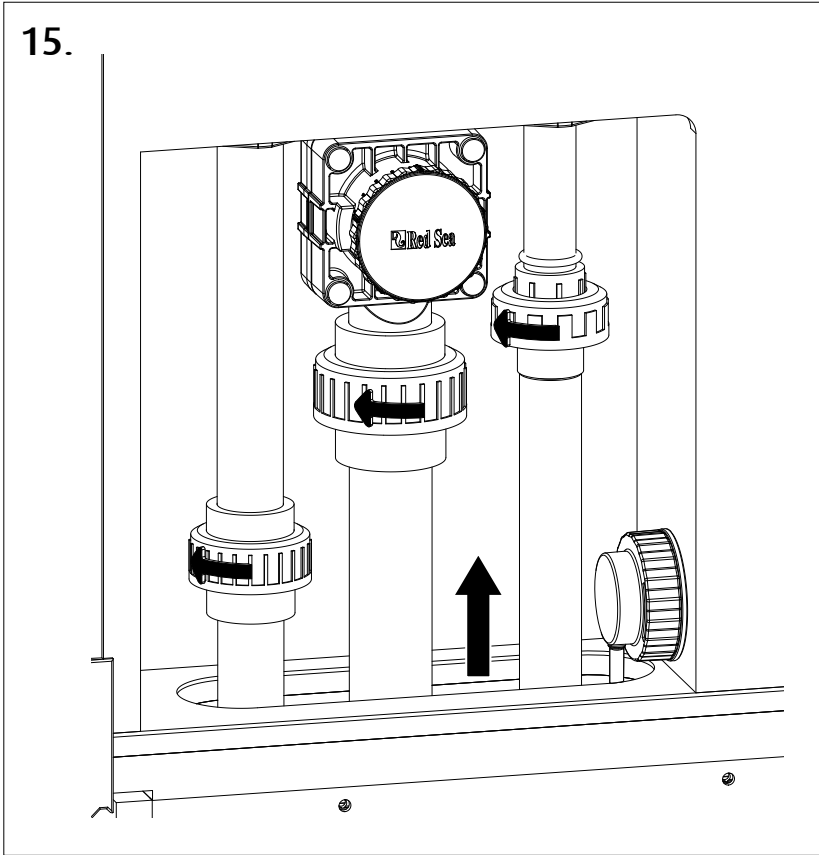

16.

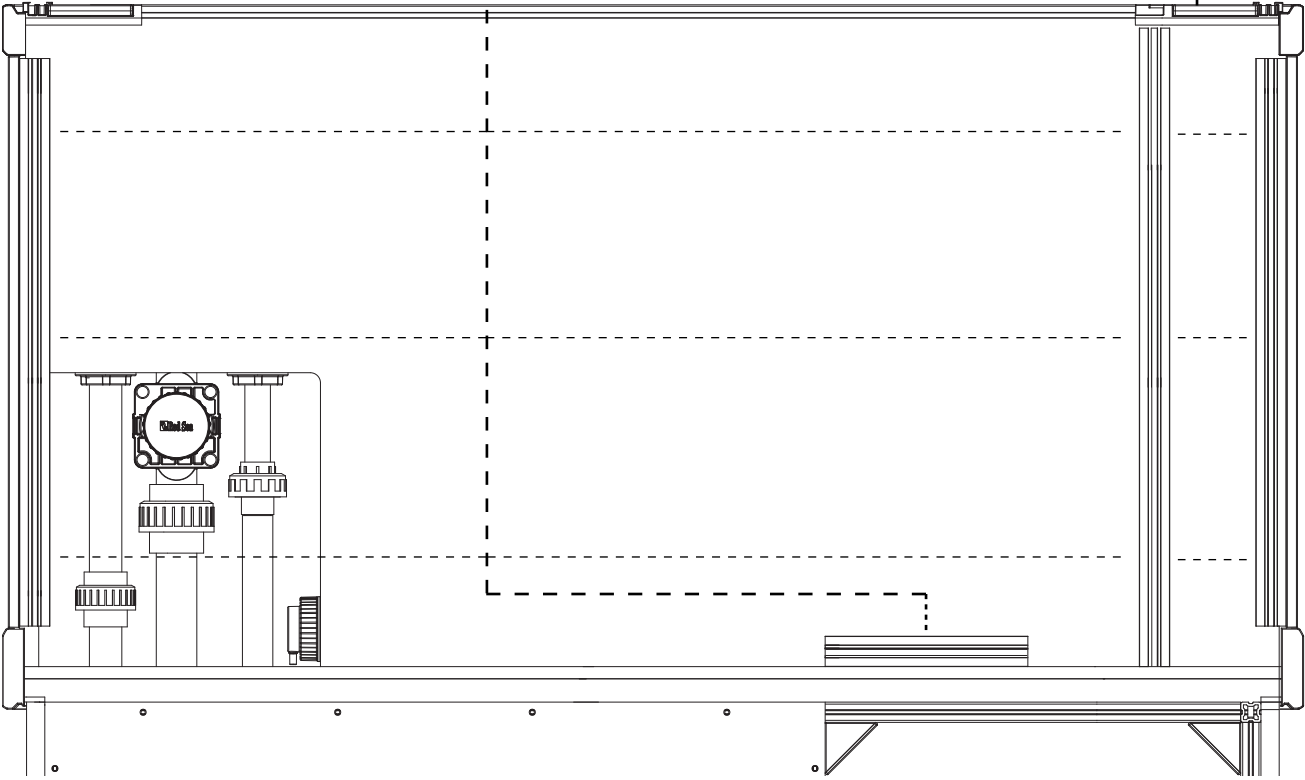
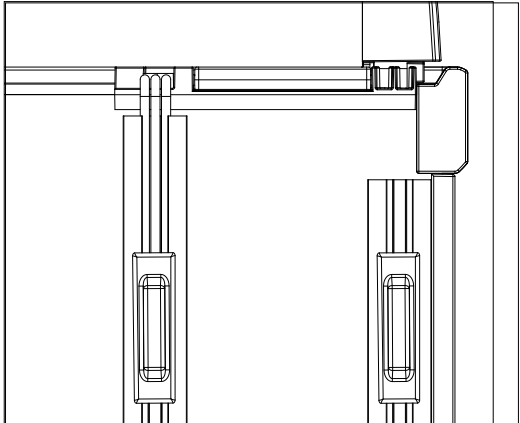
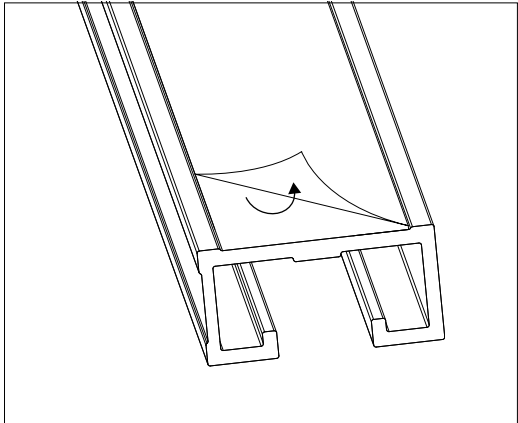

17.

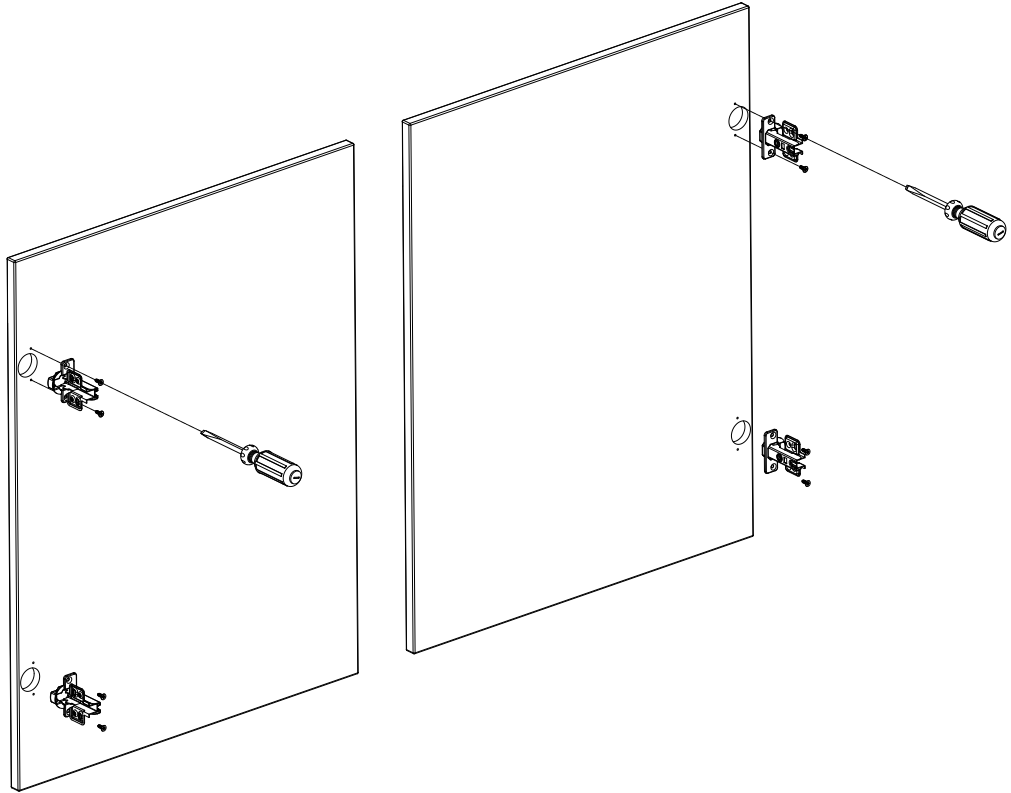

18.

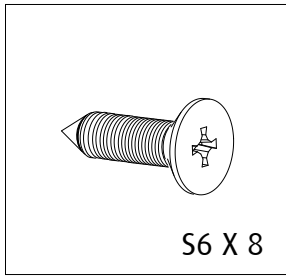
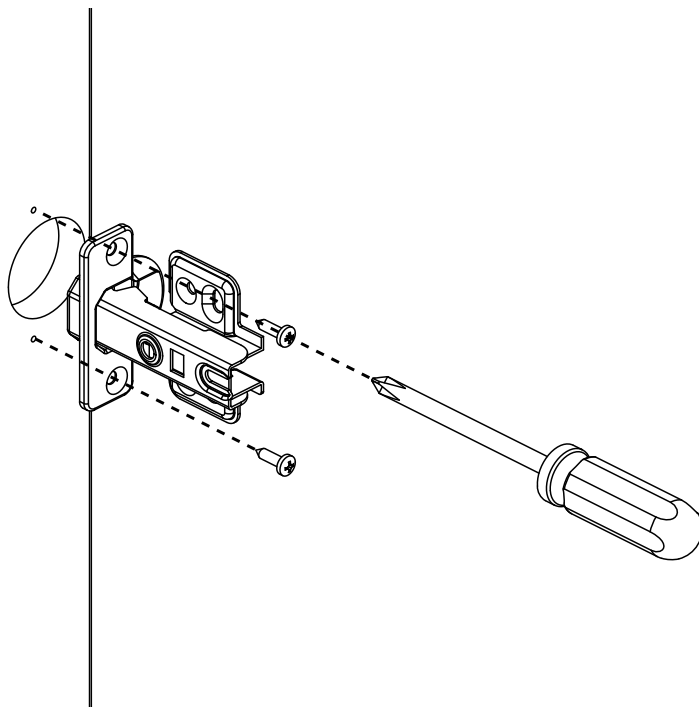

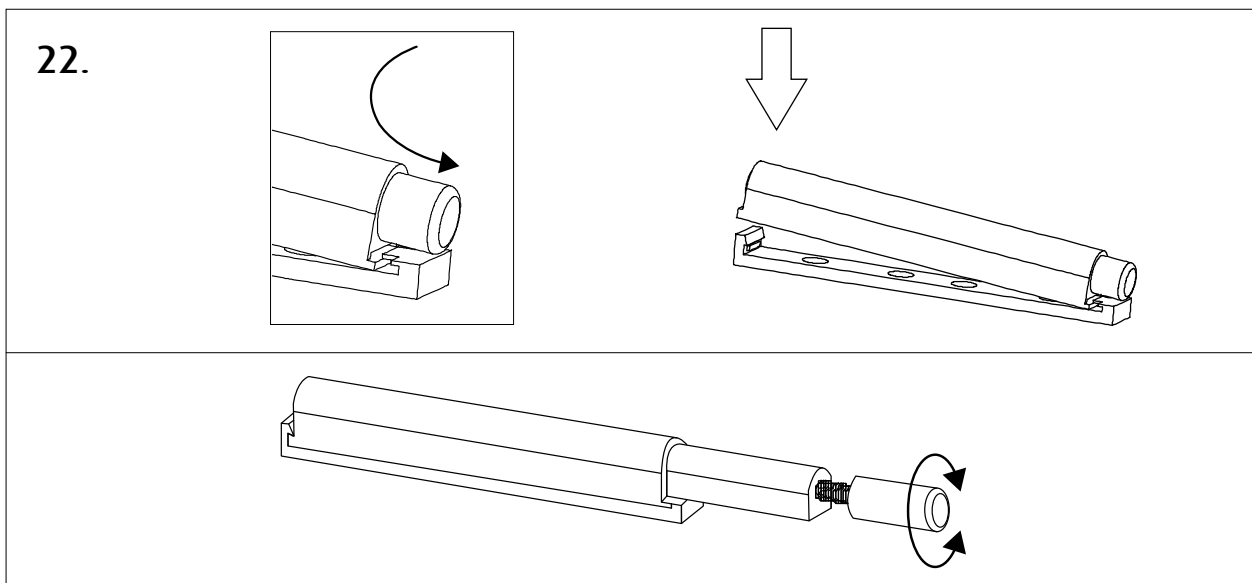
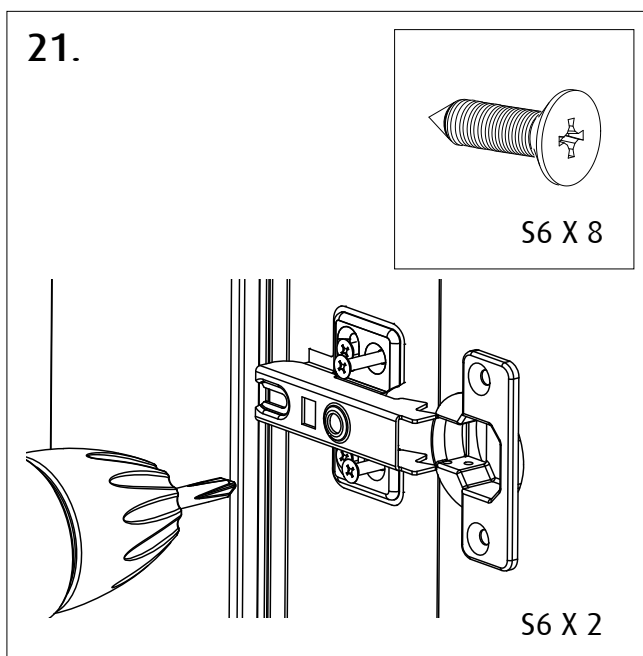
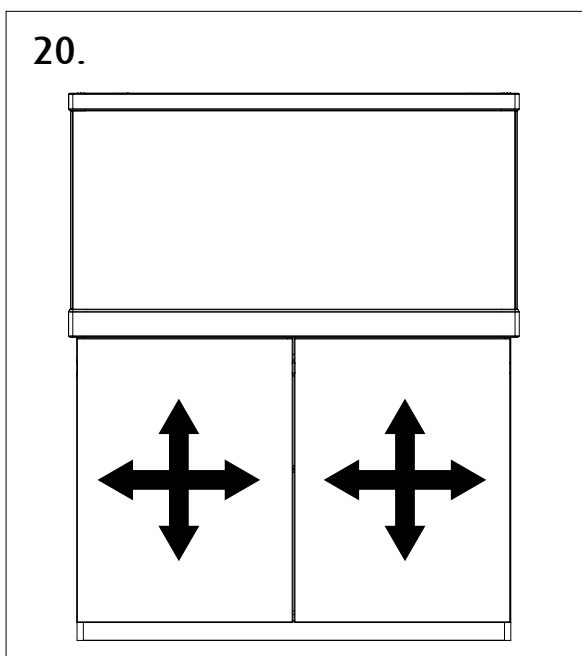
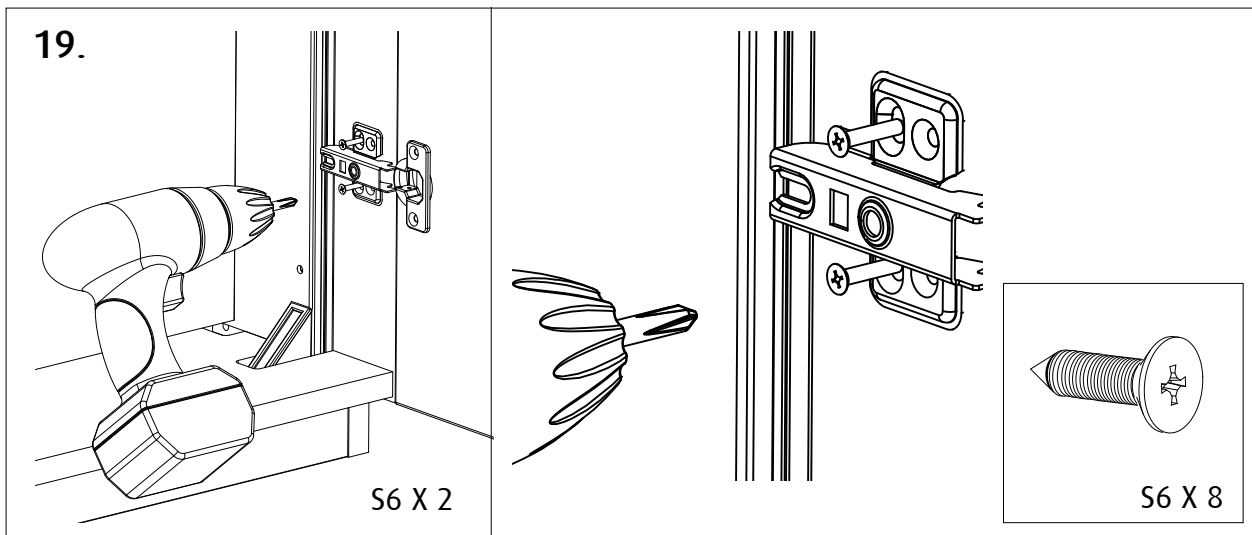

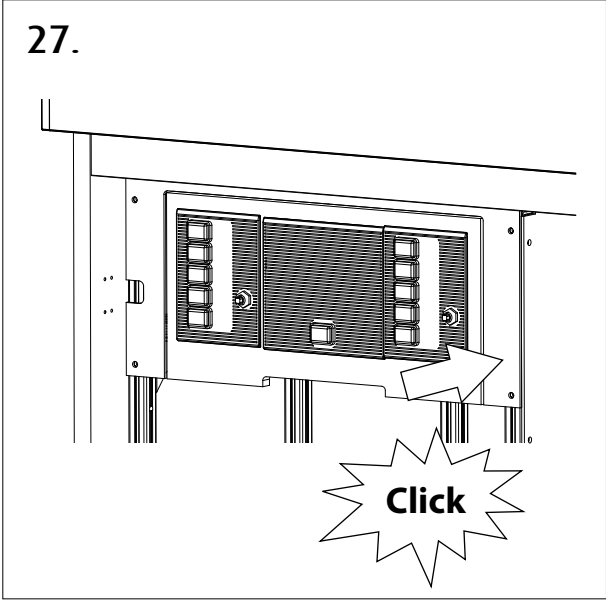
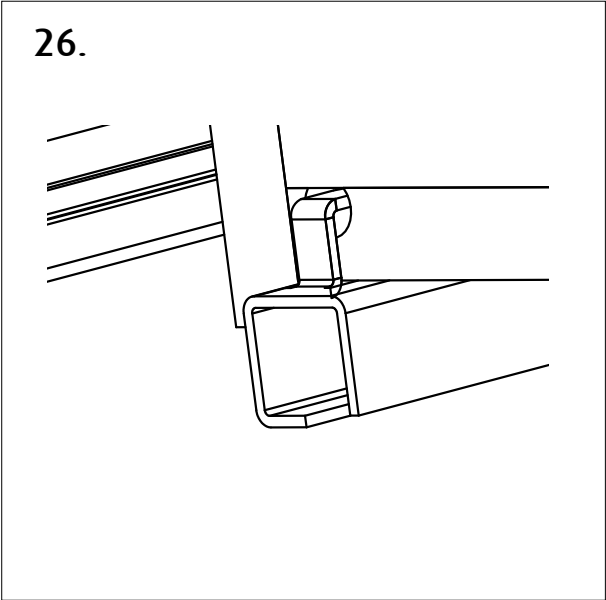
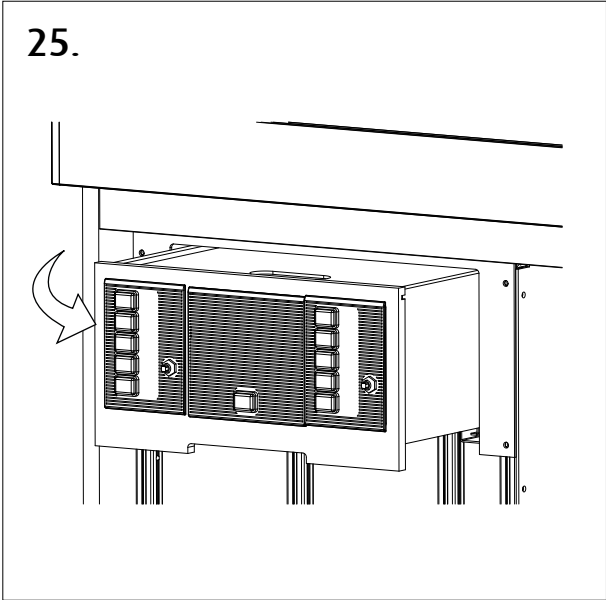
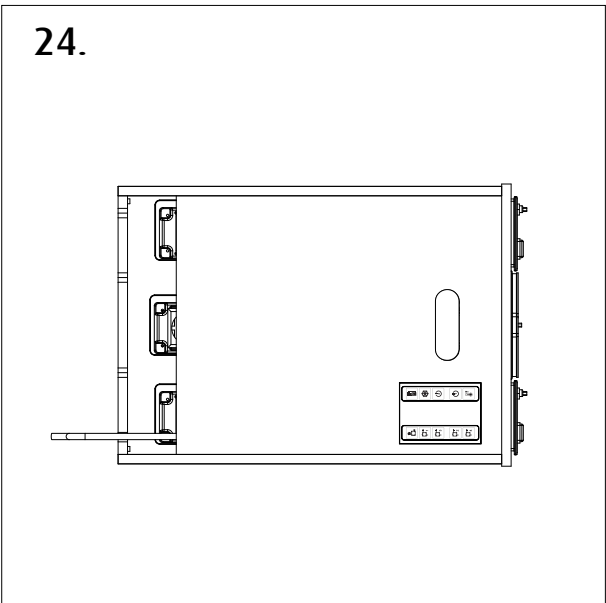
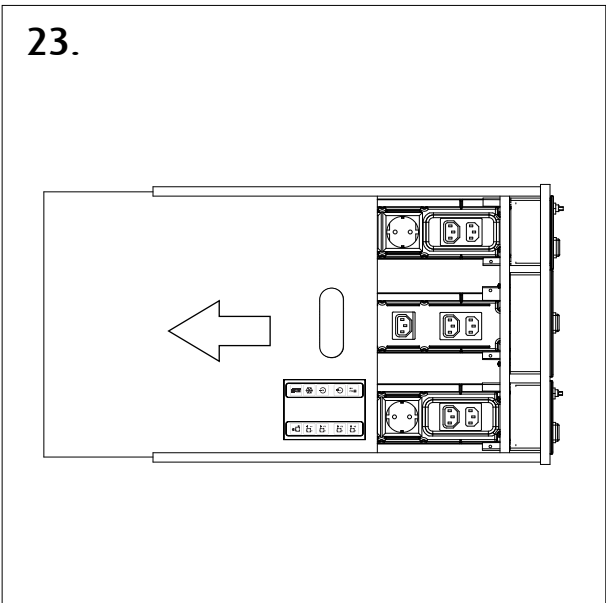

#5

Pumps & Skimmer | Pumpen & Abschäumer
Pompes et écumeur | 循环泵和蛋分

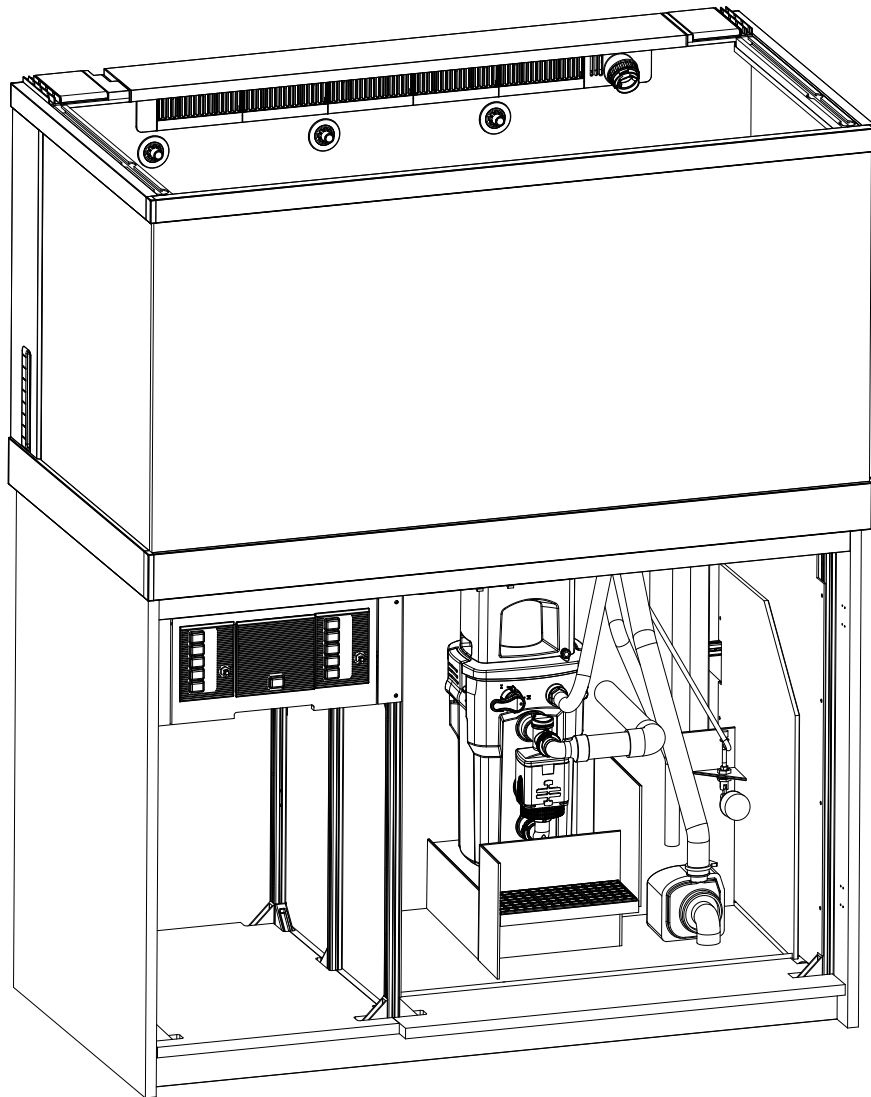

Parts | Teile | Éléments | 部件

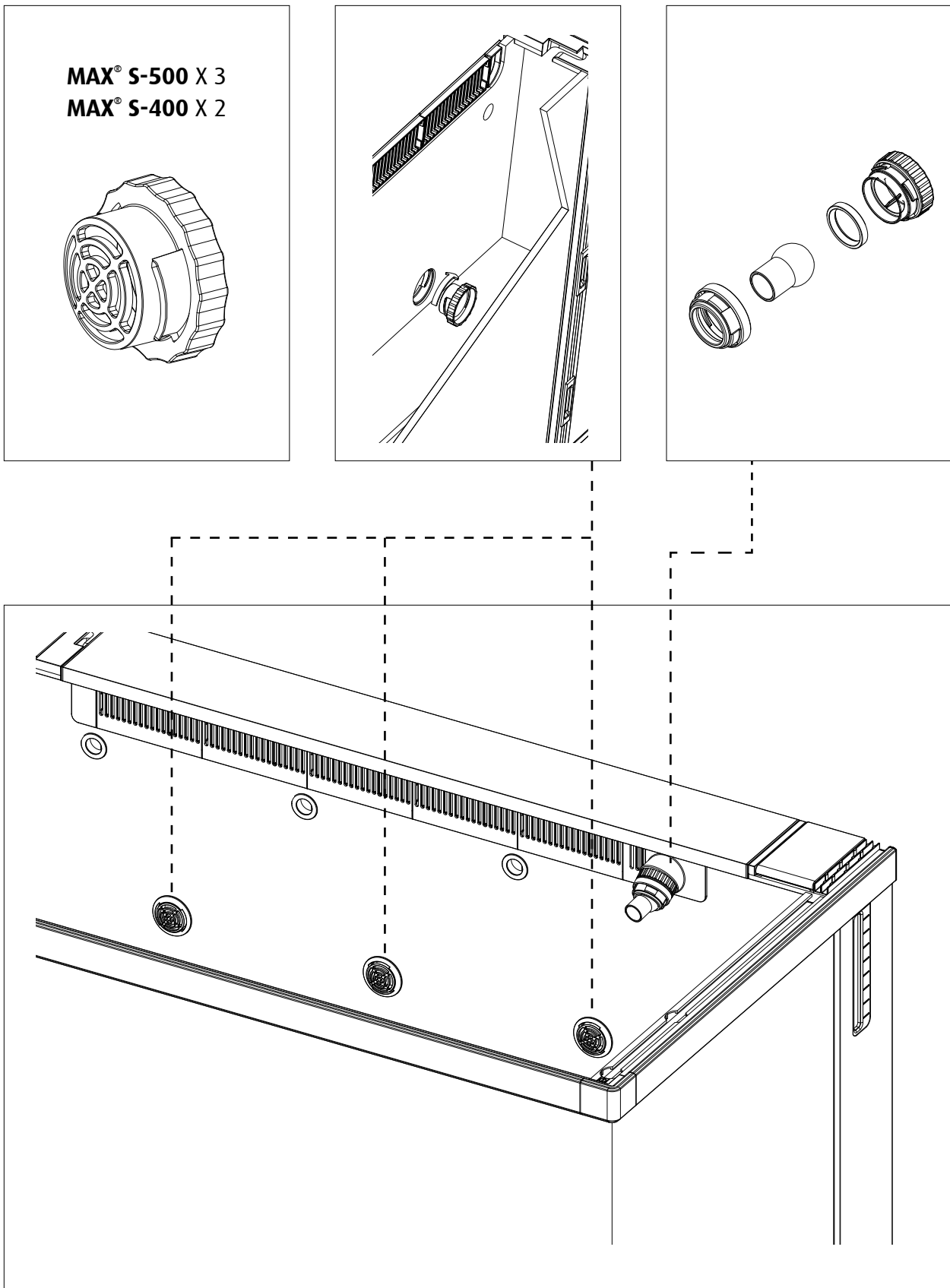

MAX® S-500 X 3

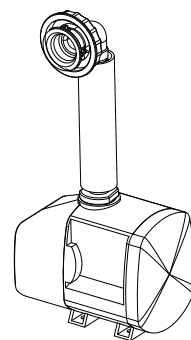

P1

P2

P3

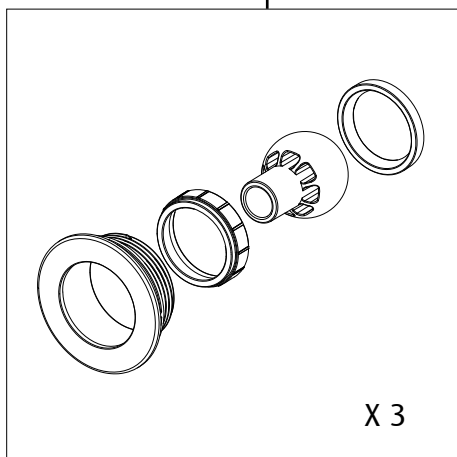
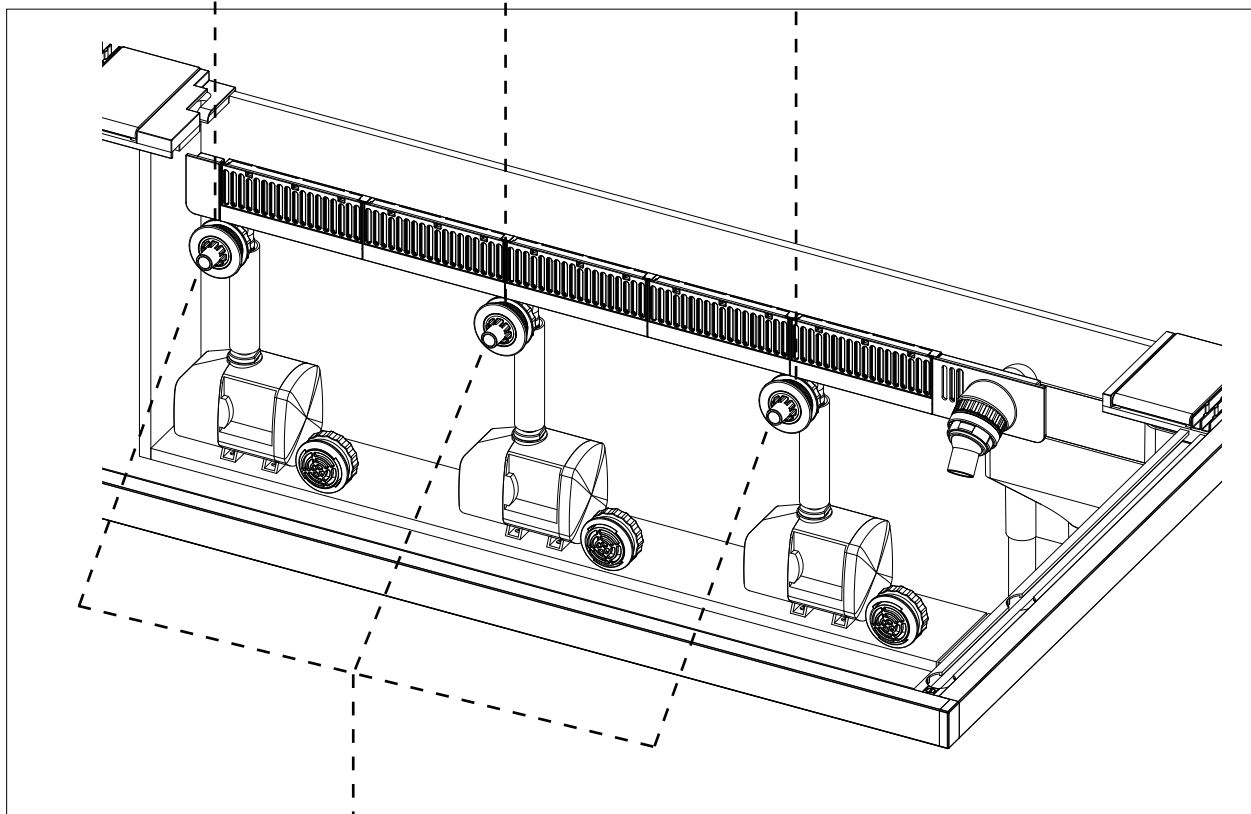

X 3

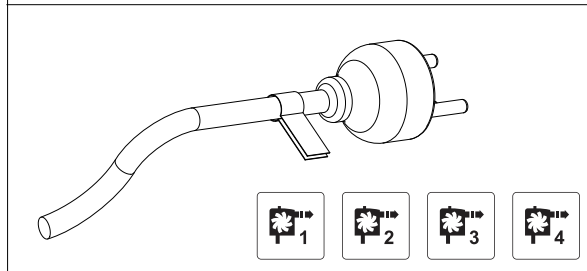
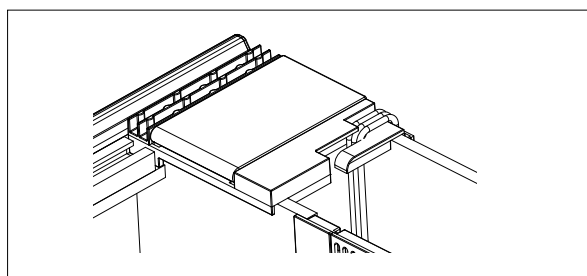

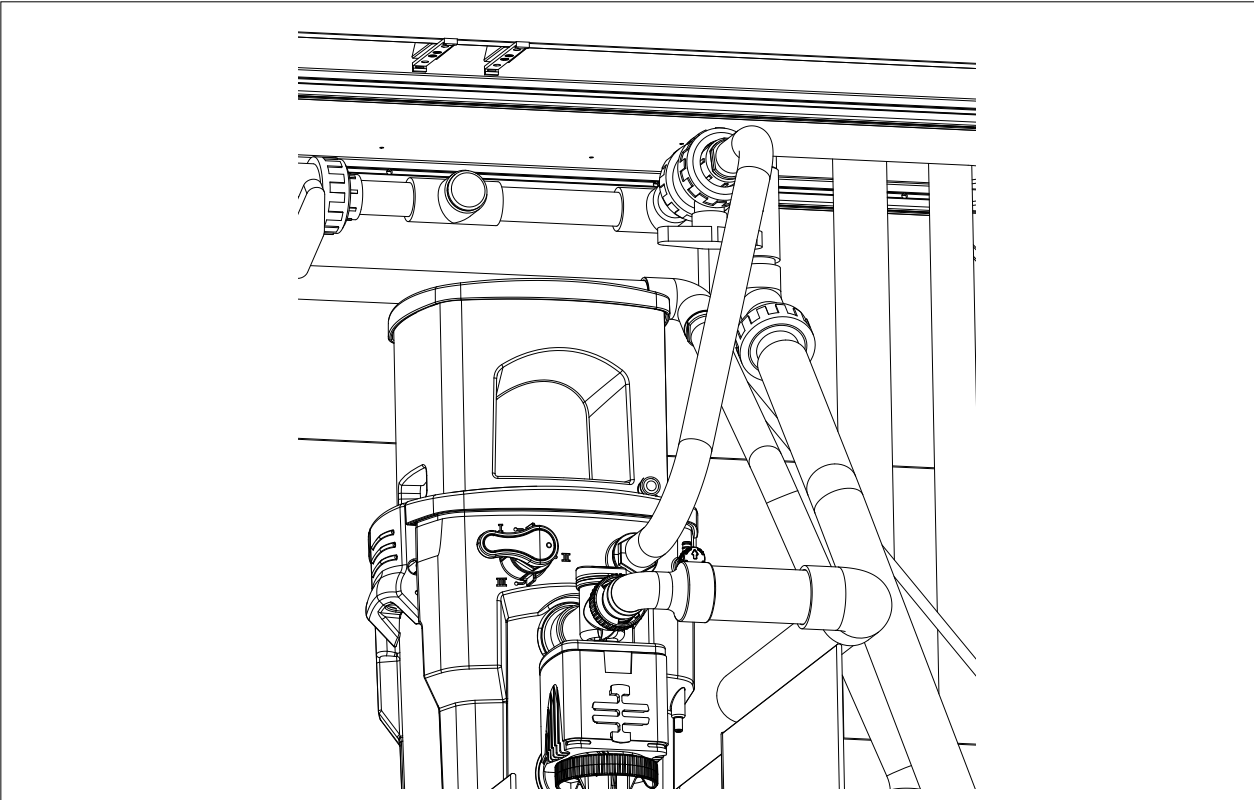
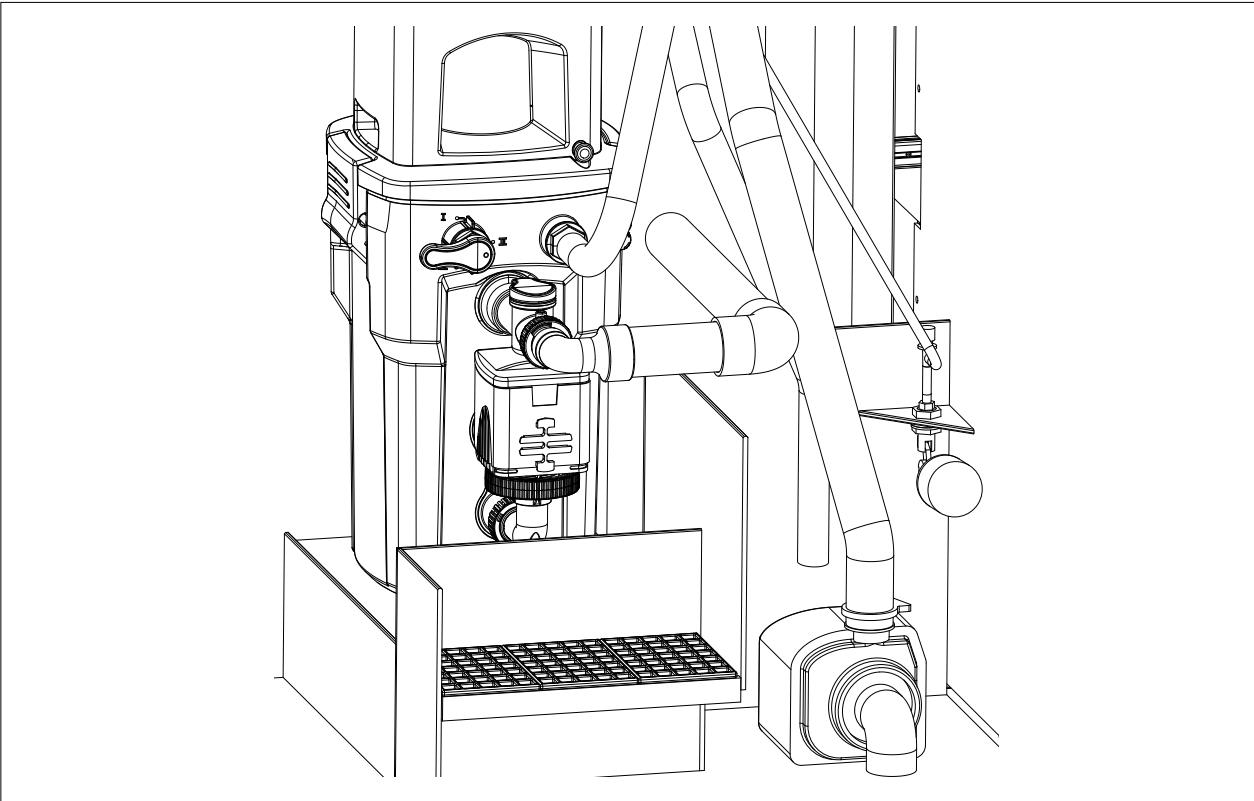

#6

Lighting & Power | Beleuchtung und Strom
Eclairage et Power Center | 照明设备和电源中心

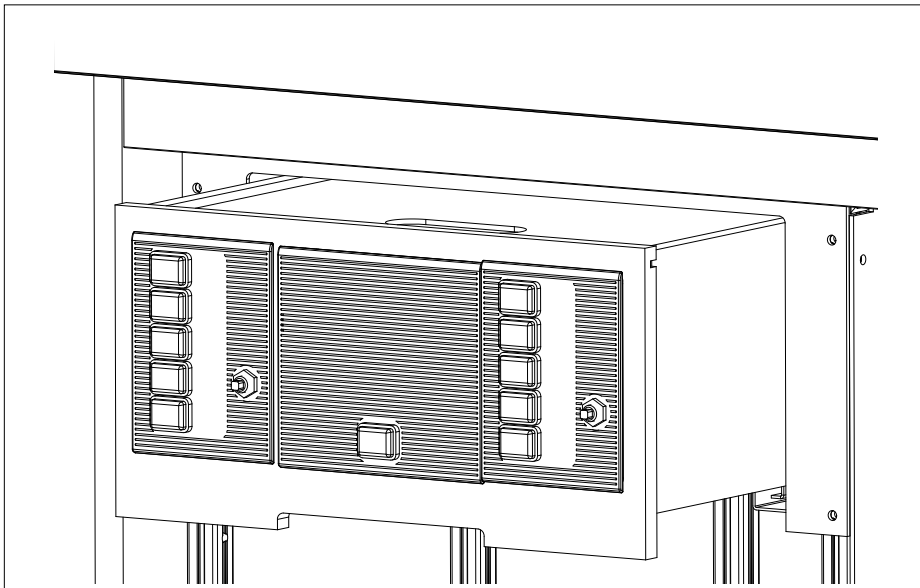
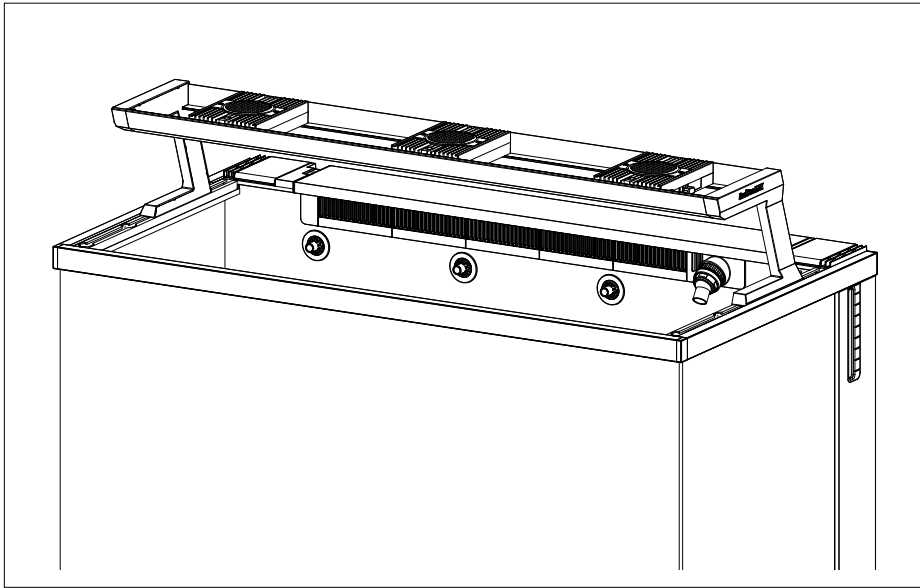

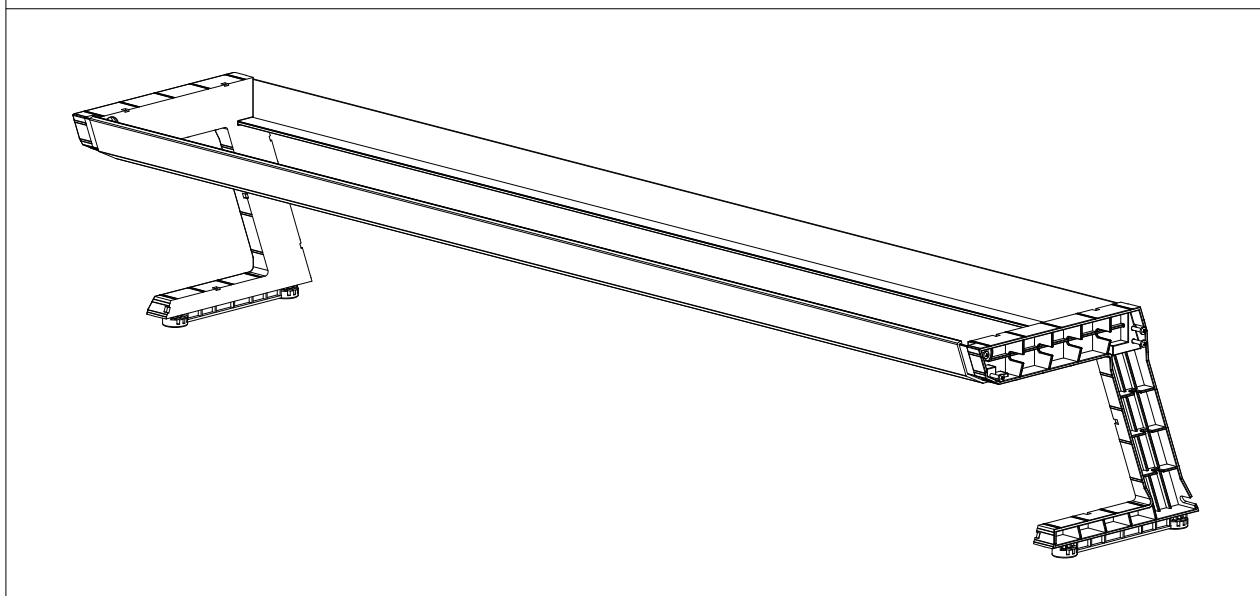
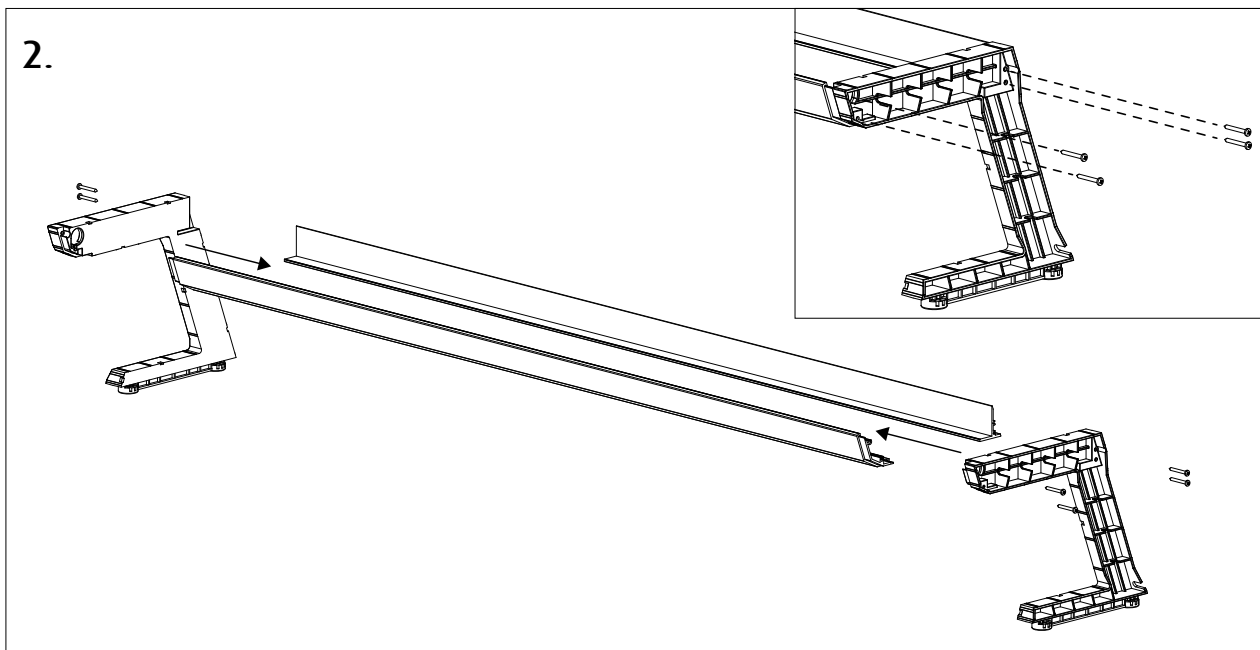
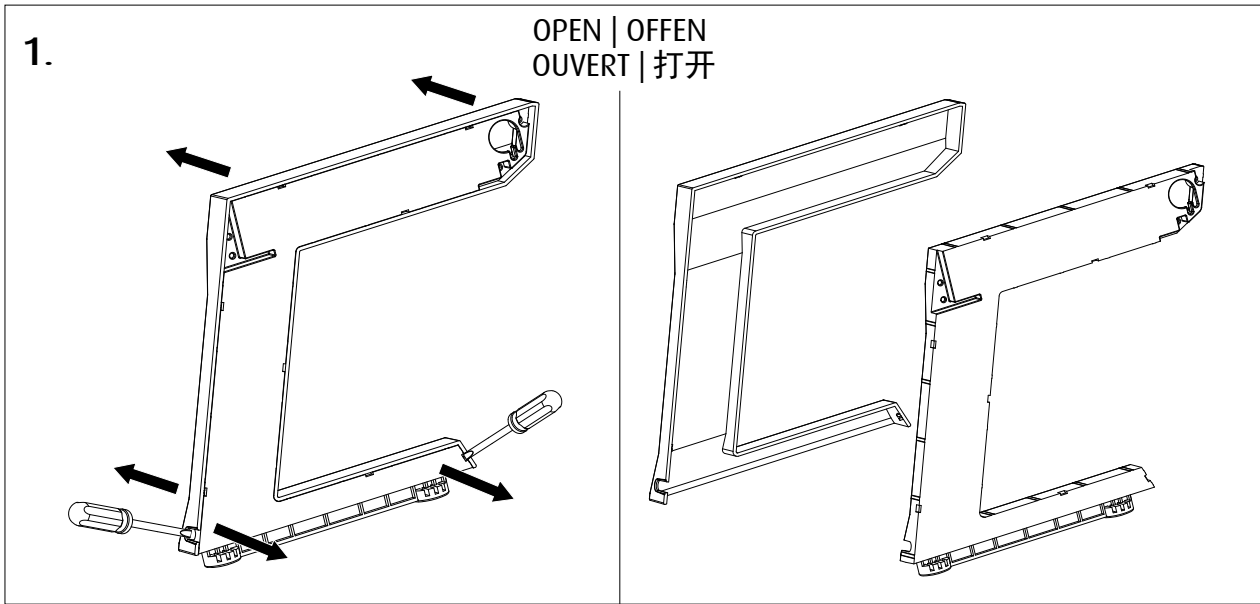

MAX® S-400

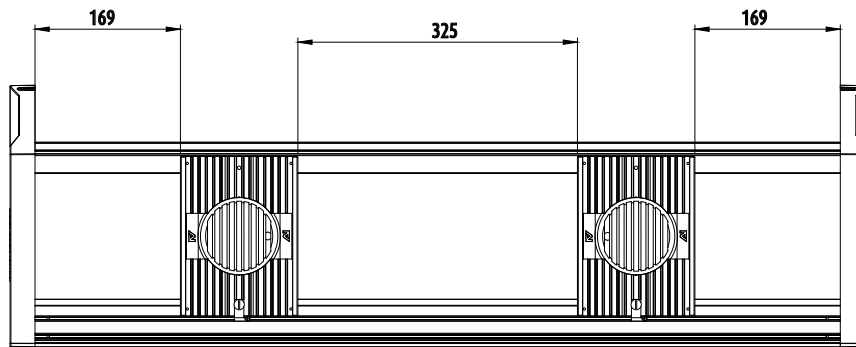

MAX® S-500

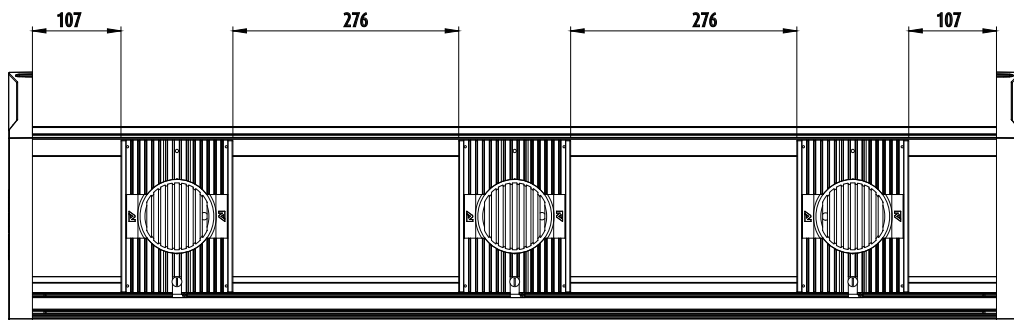

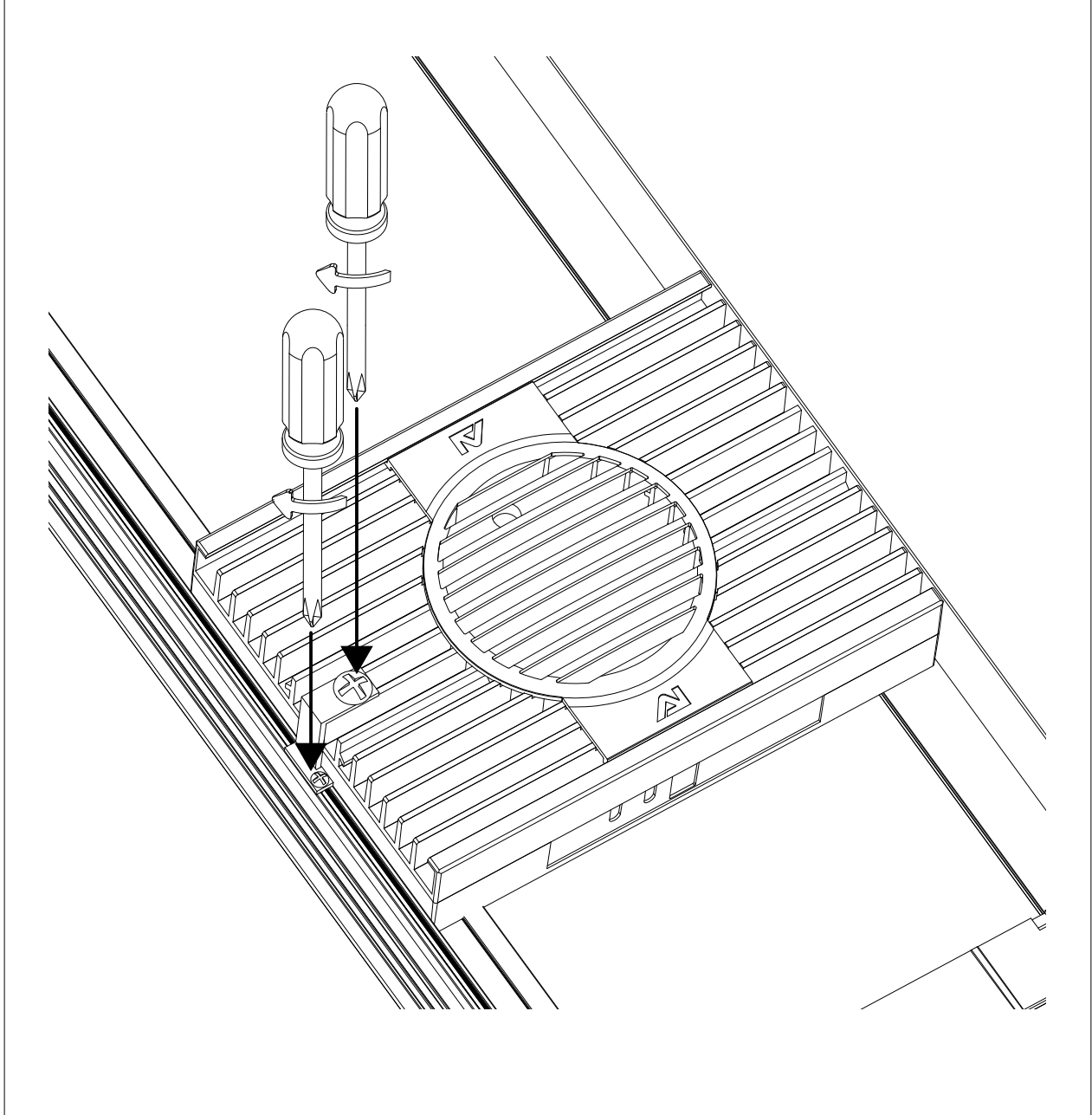
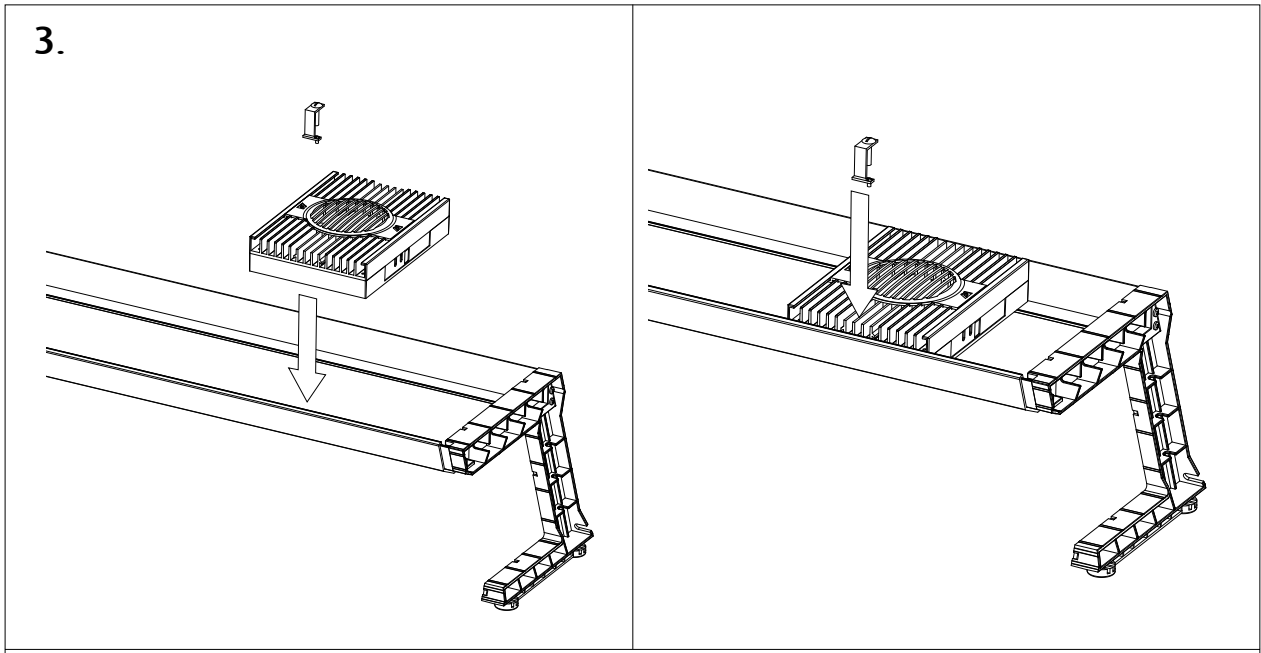

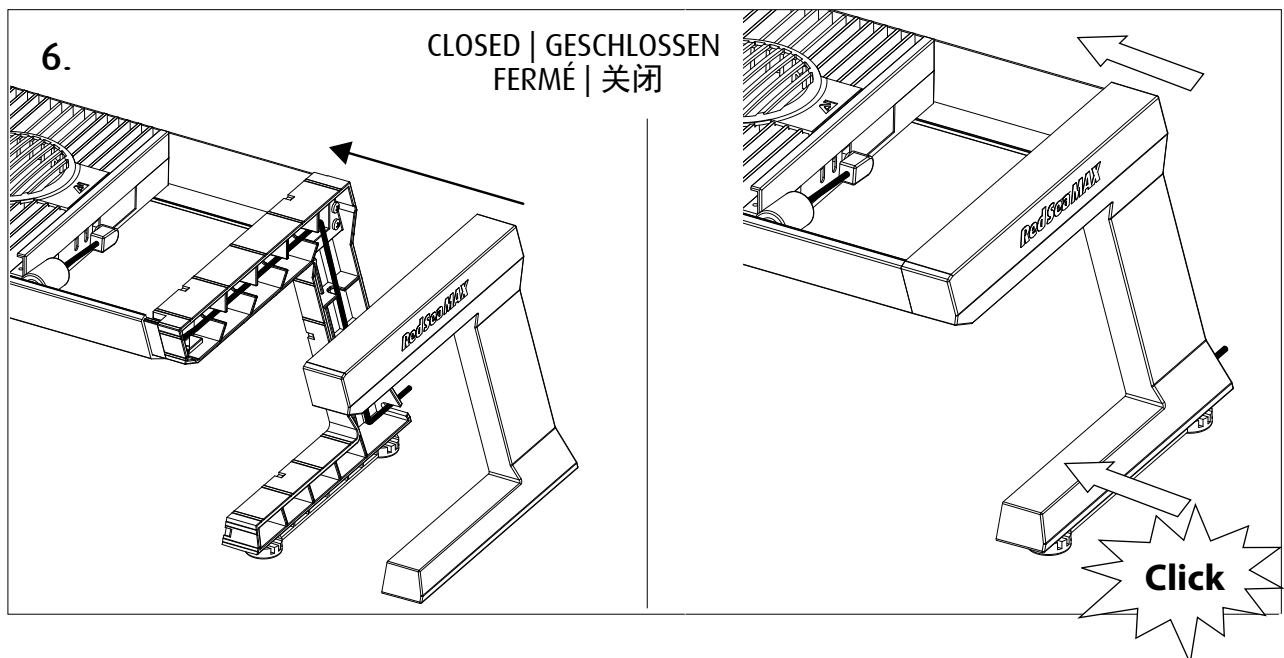
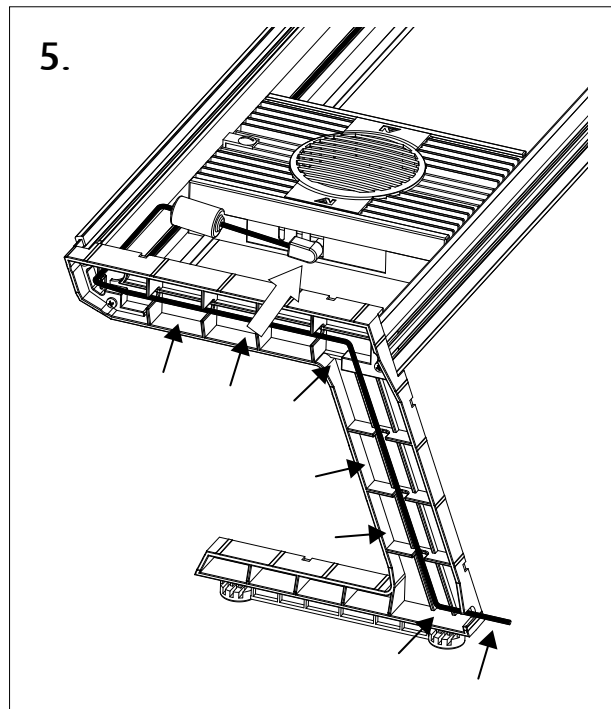
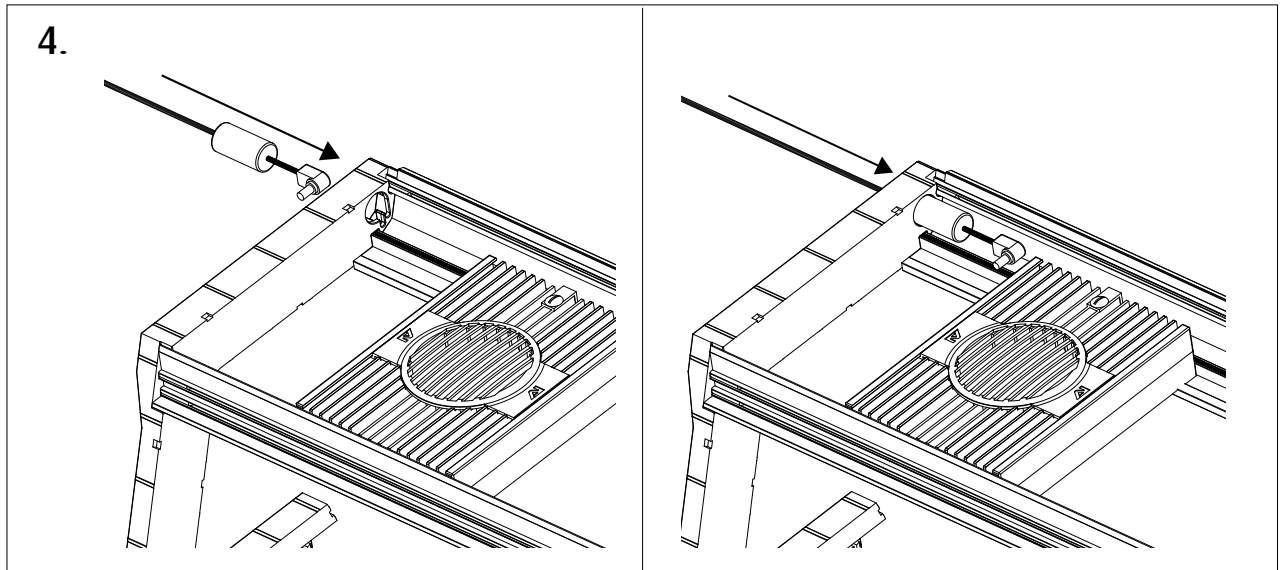

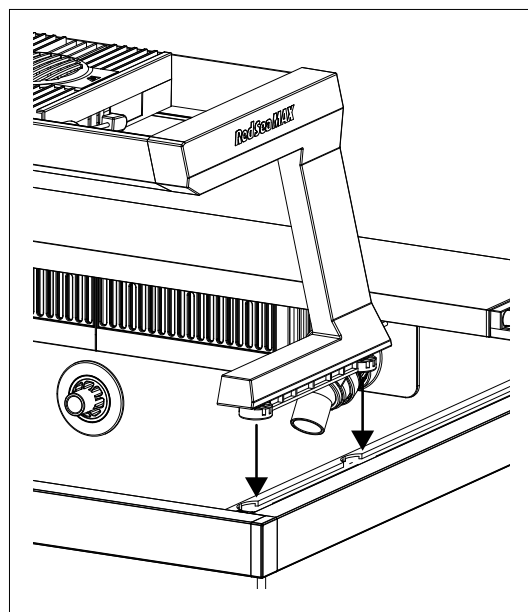
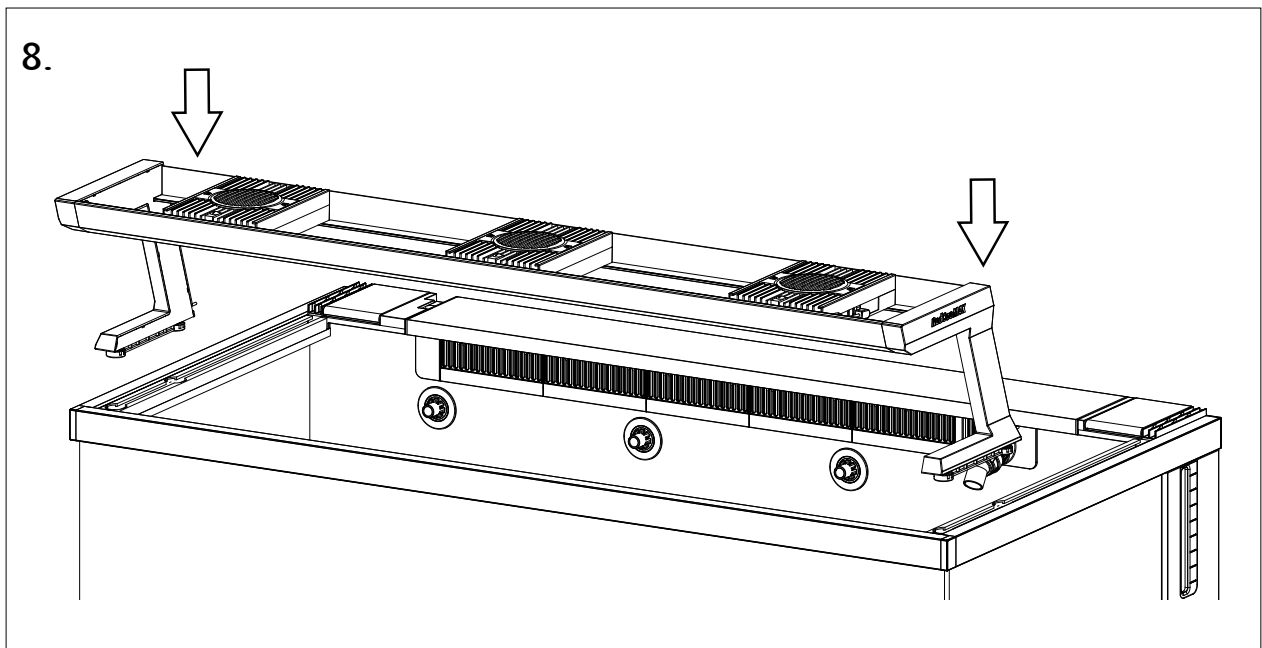
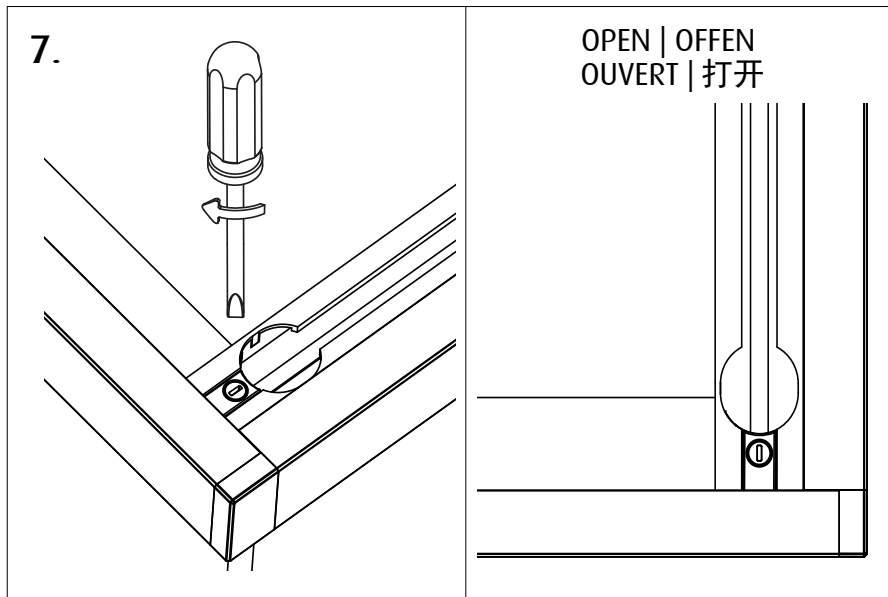

9.

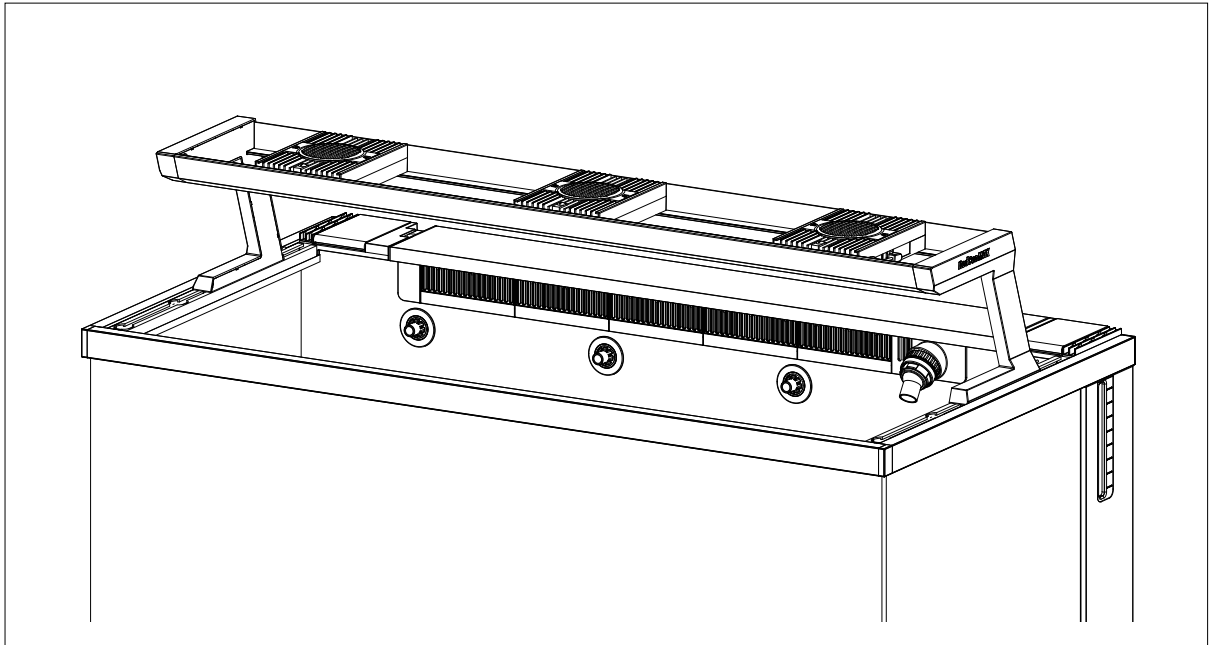
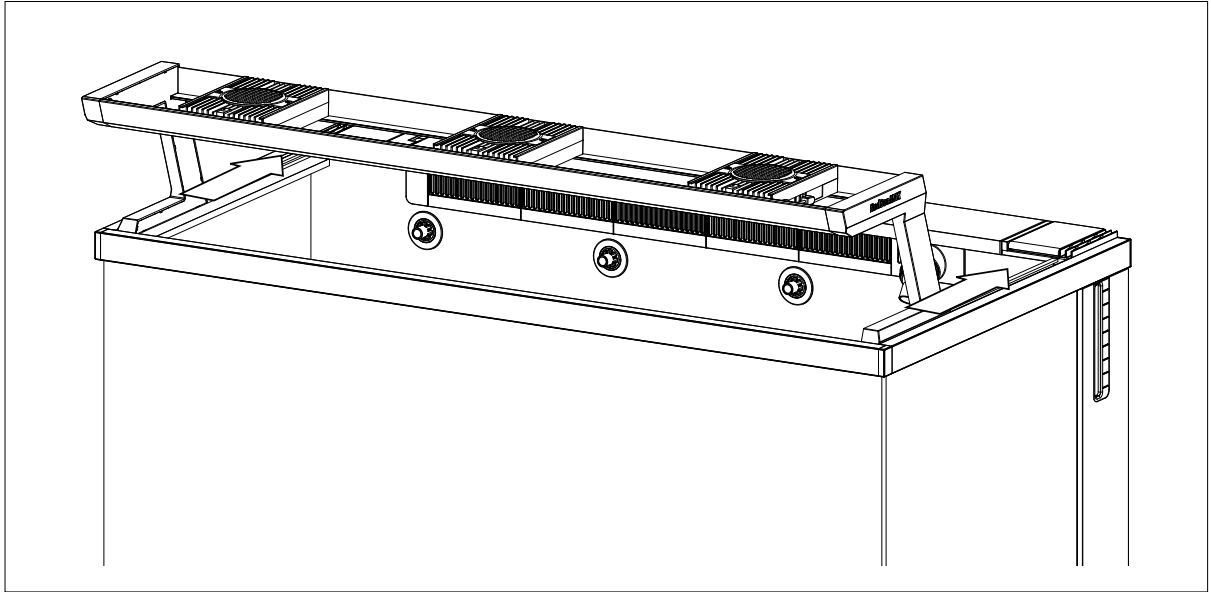

10.

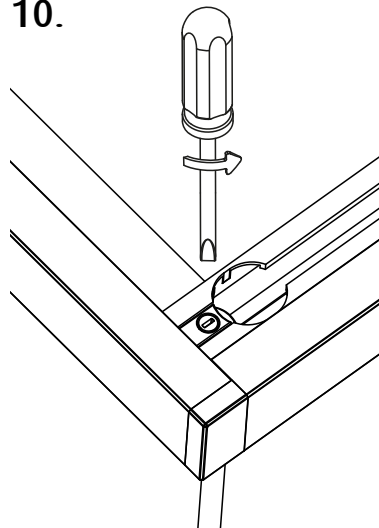

CLOSED | GESCHLOSSEN
FERMÉ | 关闭

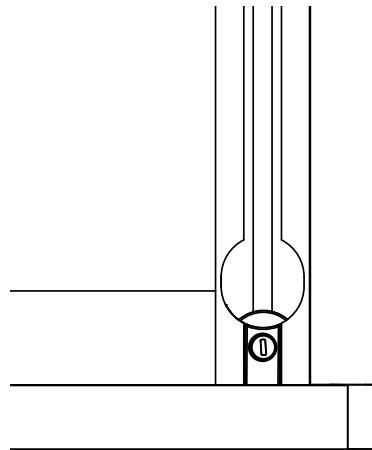

11.

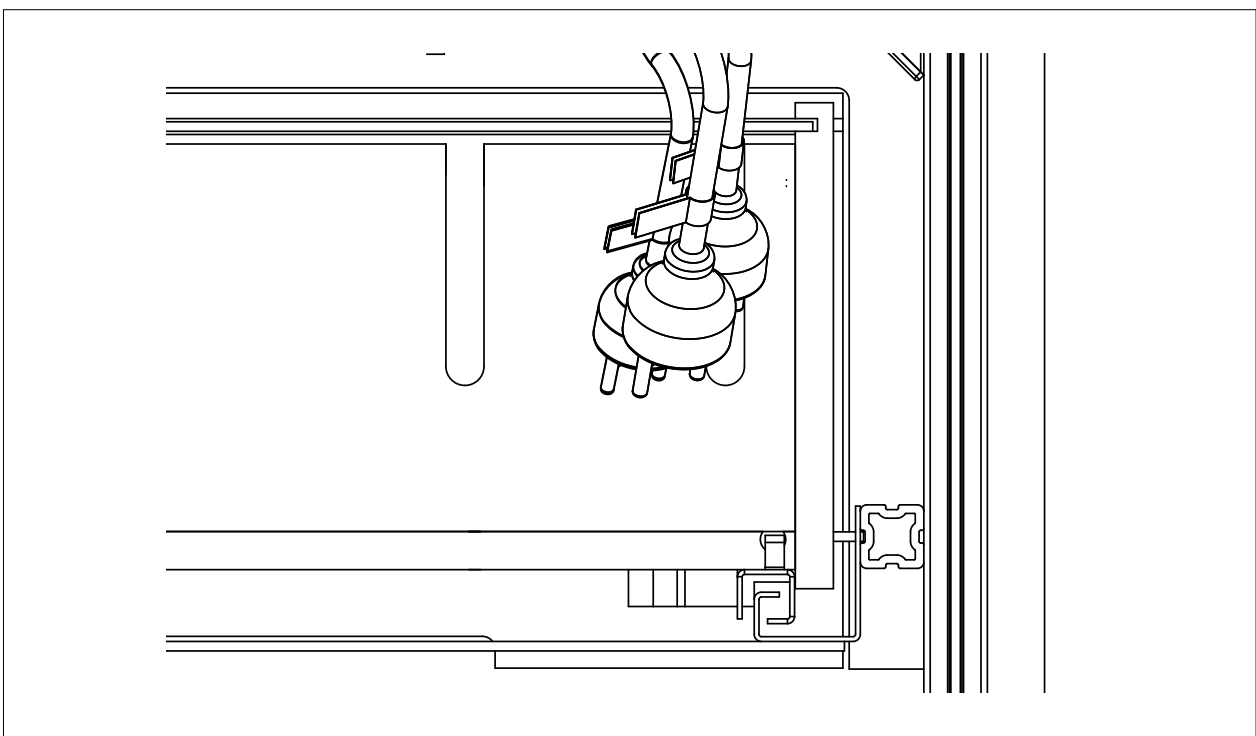
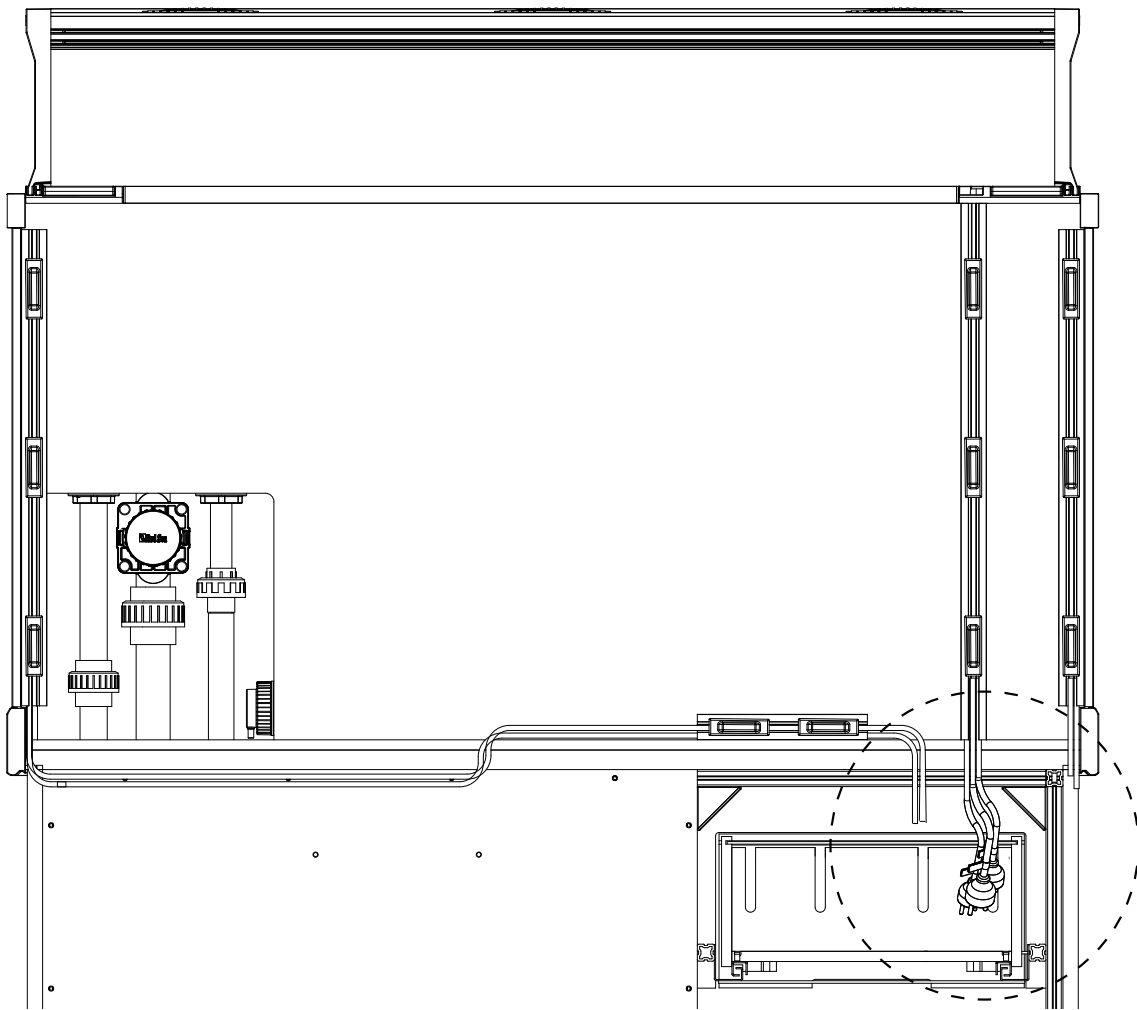

12.

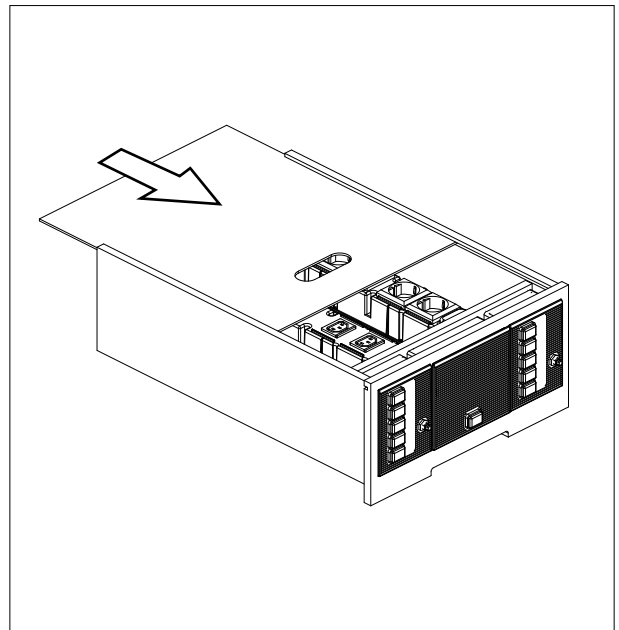
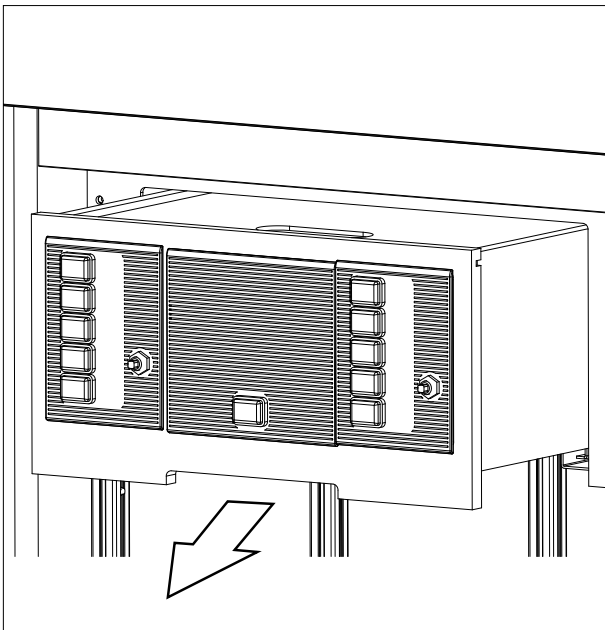
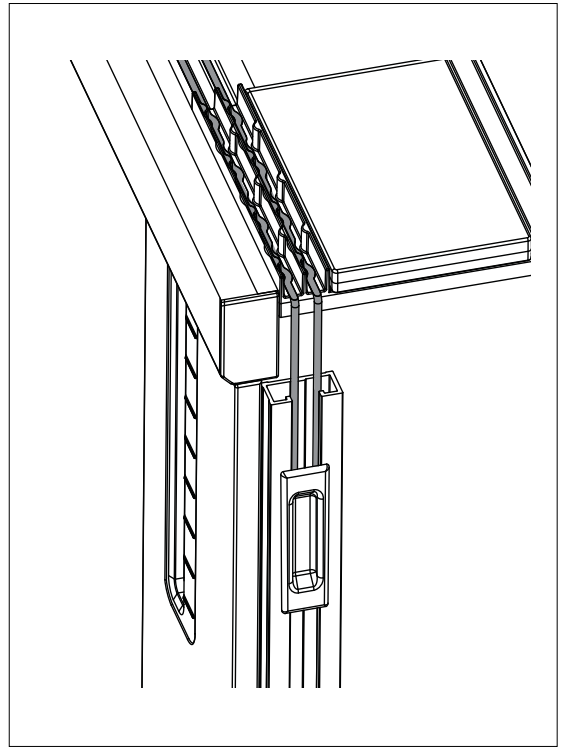
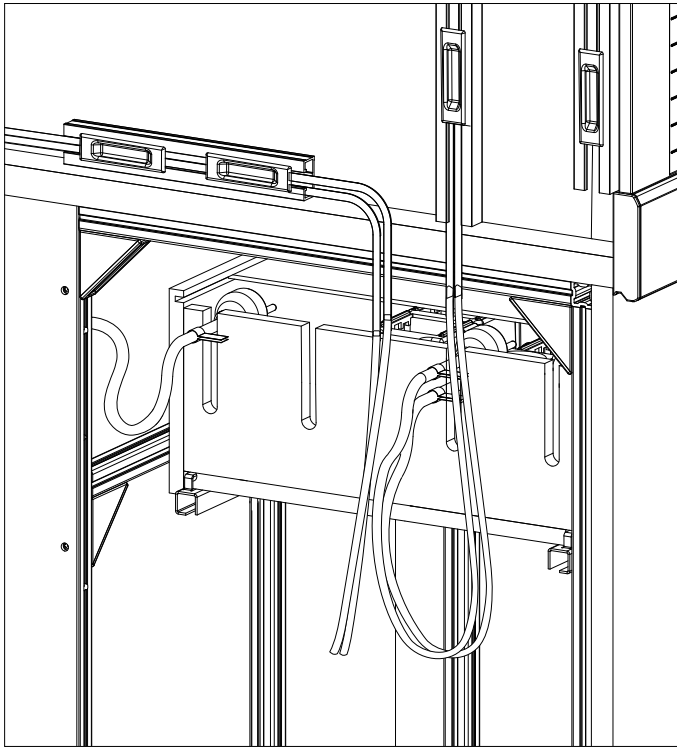

North America

Red Sea U.S.A & Canada
18125 Ammi Trail
Houston, TX 77060
Tel. : +1-888-RED-SEA9
usa.info@redseafish.com

UK & Ireland

Red Sea Aquatics (UK) Ltd
PO Box 1237
Cheddar, BS279AG
Tel. : +44 (0) 203 3711437
Fax : +44 (0) 800 0073169
uk.info@redseafish.com

Europe

Red Sea Europe
ZA de la St-Denis
F-27130 Verneuil s/Avre,
France
Tel: (33) 2 32 37 71 37
eur.info@redseafish.com

Germany & Austria

Red Sea Deutschland
Büro Deutschland
Prinzenallee 7 (Prinzenpark)
40549 Düsseldorf
Tel: 0211-52391 481
info.de@redseafish.com

Asia Pacific

Red Sea Aquatics Ltd
2310 Dominion Centre
43-59 Queen's Road East
Hong Kong
Tel: +86-020-6625 3828
info.china@redseafish.com

China

Red Sea Aquatics (GZ) Ltd.
Block A3, No.33 Hongmian Road,
Xinhua Industrial Park,
Huadu District, Guangzhou City,
China, Postal code 510800.
Tel: +86-020-6625 3828
info.china@redseafish.com



PRINTING INSTRUCTIONS

To print **only** the Assembly Instructions Manual, print pages 58-114.

Red Sea MAX[®] S-650 LED

Complete Coral Reef Systems



MAX[®]S-650 LED







Assembly Instructions | Montageanleitungen

Notice de montage | 安装指南

Index

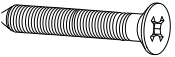
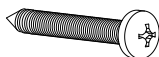
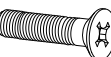
Frame Rahmen Structure 框架	5
Cabinet Unterschrank Meuble 底柜	17
Positioning Ausrichtung Emplacement 摆放位置	27
Aquarium & Sump Aquarium & Filtersumpf Aquarium et decantation 水族箱和过滤缸	29
Pumps & Skimmer Pumpen & Abschäumer Pompes et écumeur 循环泵和蛋分	49
Lighting & Power Beleuchtung und Strom Eclairage et Power Center 照明设备和电源中心	53

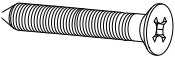
Screw List | Liste der Schrauben | Liste des vis | 螺丝清单

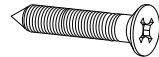
Screw # Schraube # Vis # 螺丝 #	Picture Bild Dessin 图片	Description Beschreibung Description 介绍	Pack Paket Sachet 包装	Quantity Anzahl mfsdijf Quantité 数量
S (V) 1		Torx Head Rundkopf Tête ronde ST 5 x 12mm	A Screw Pack Schraubenpaket Sachet de vis 螺丝包	3 X 50
S (V) 2		Countersunk Senkkopf Tête fraisée ST 5 x 14mm	B Screw Pack Schraubenpaket Sachet de vis 螺丝包	28
S (V) 3		Countersunk Senkkopf Tête fraisée ST 4 x 35mm	B Screw Pack Schraubenpaket Sachet de vis 螺丝包	6
S (V) 8		Round Head Rundkopf Tête ronde ST 3.5 x 30mm	B Screw Pack Schraubenpaket Sachet de vis 螺丝包	3
S (V) 4		Countersunk Senkkopf Tête fraisée M4 x 25mm	Cabinet Parts Pack Paket für Unterschrank-Teile Visserie meuble 木柜板材螺丝包	8
S (V) 6		Countersunk Senkkopf Tête fraisée 4 x 16mm	Hinge Set Scharnier-Set Charnières 门铰链螺丝包	36
S (V) 3		Countersunk Senkkopf Tête fraisée ST 4 x 35mm	Pipe Clip Pack Rohrclip-Paket Fixation tuyaux 管夹螺丝包	3
S (V) 5		Countersunk Senkkopf Tête fraisée ST 6 x 16mm	Pipe Clip Pack Rohrclip-Paket Fixation tuyaux 管夹螺丝包	2
S (V) 7		Countersunk Senkkopf Tête fraisée ST 5 x 35mm	Internal Wall pack Innenwandpaket Cloison interne 内墙板螺丝包	4

#1

Frame | Rahmen

Structure | 框架

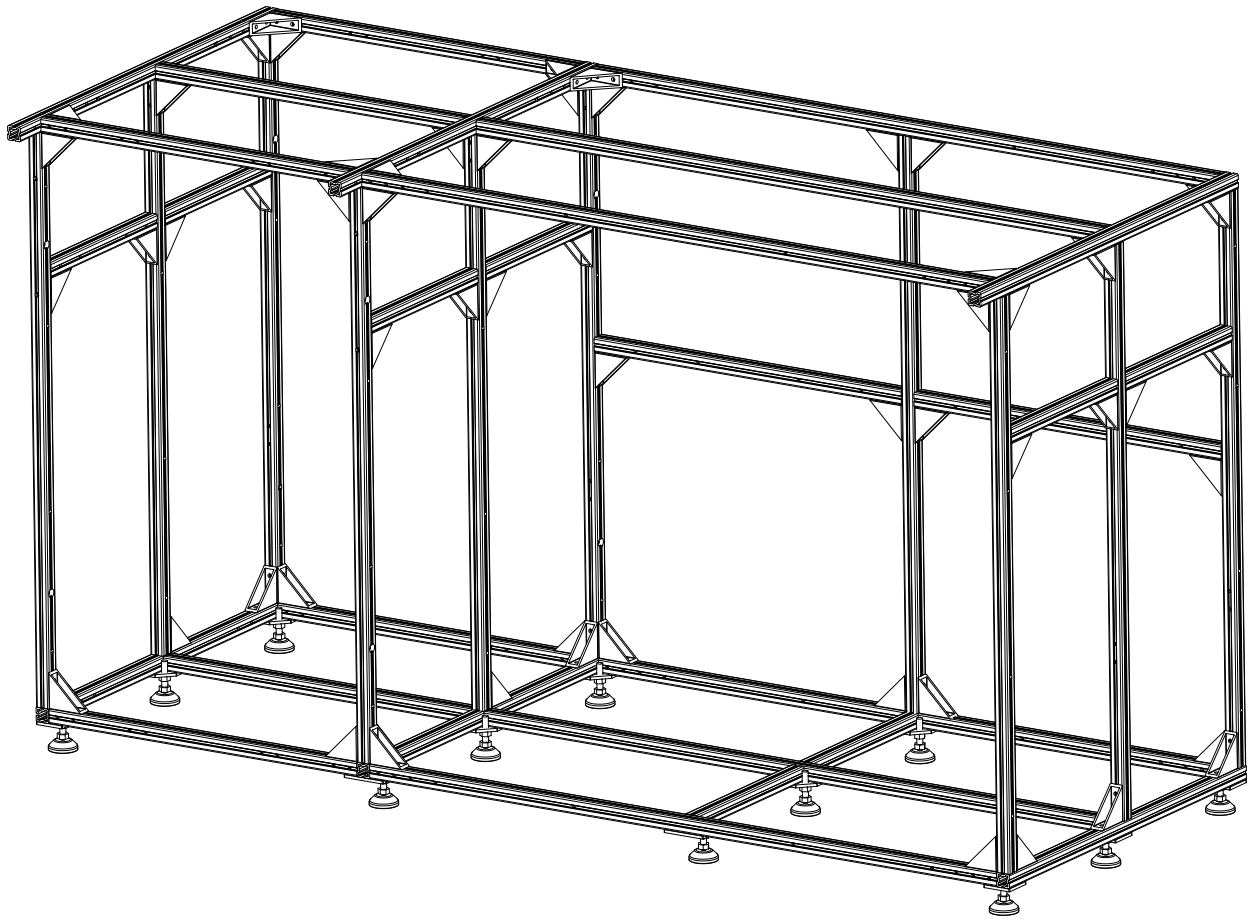

Parts | Teile | Eléments | 部件

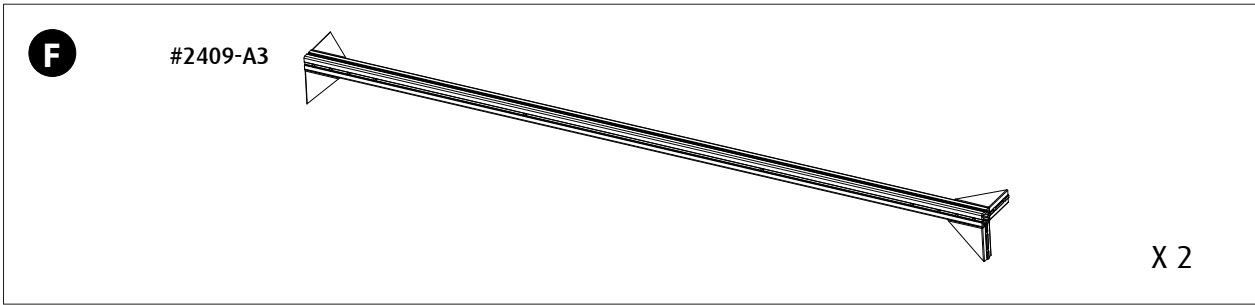
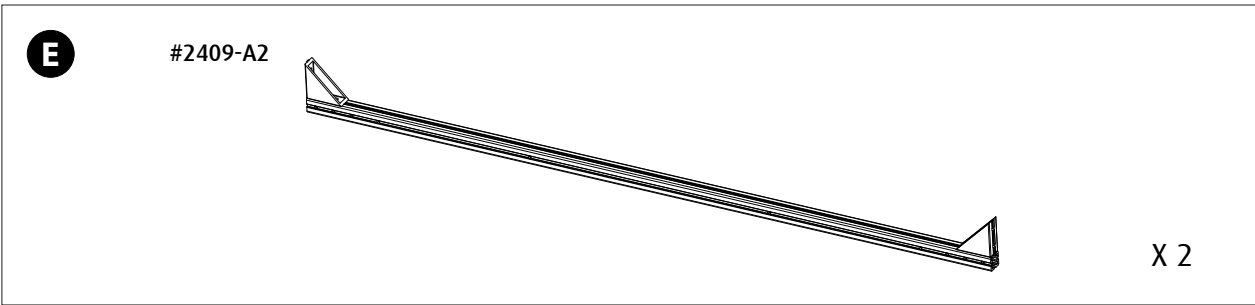
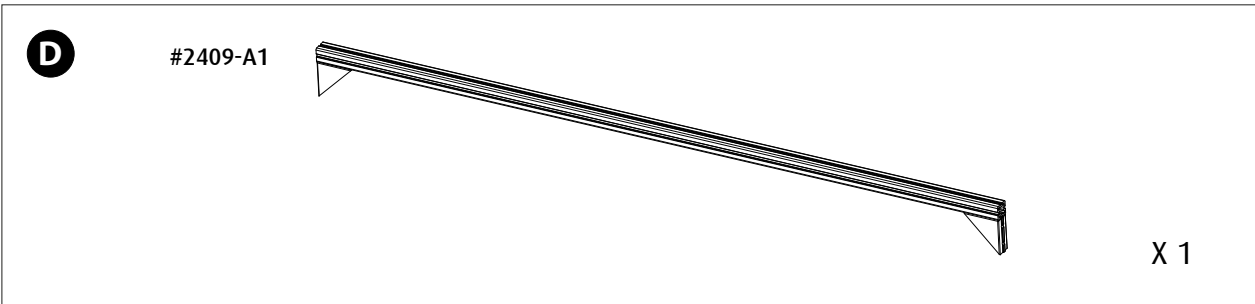
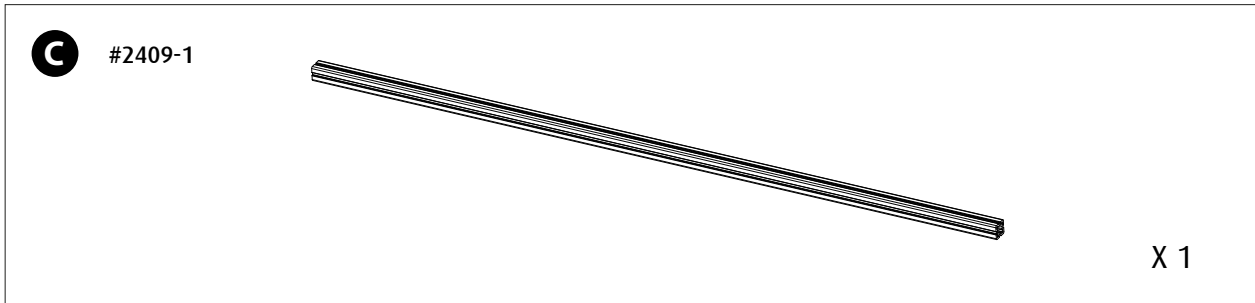
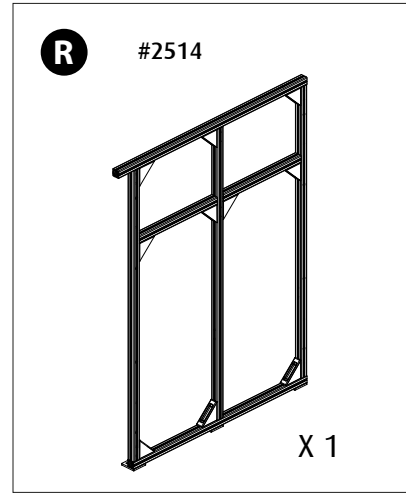
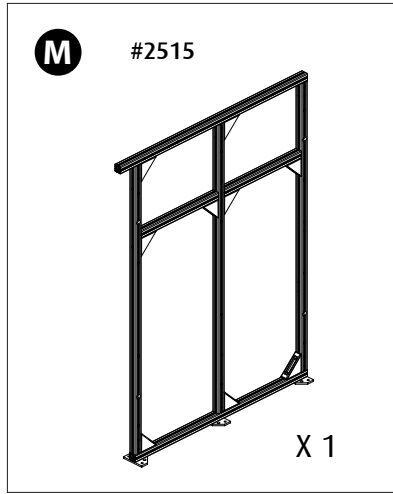
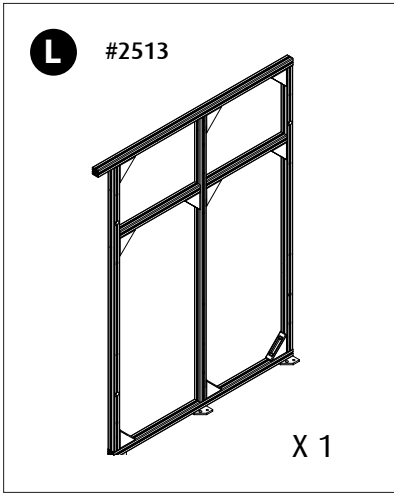

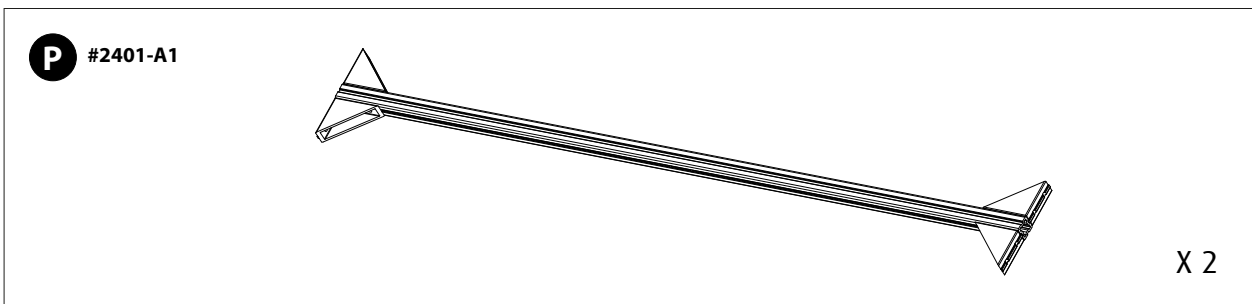
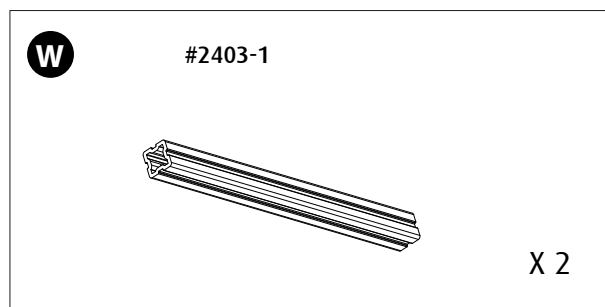
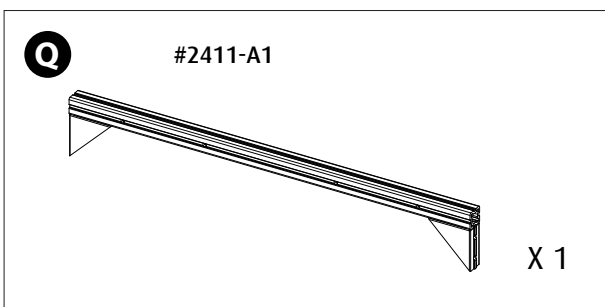
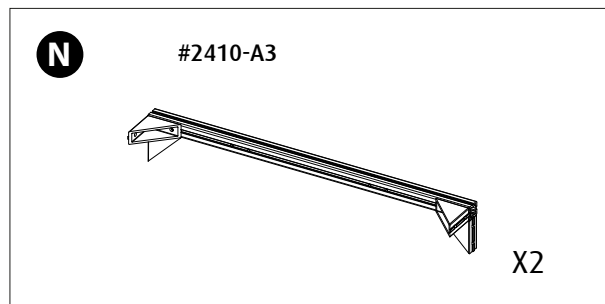
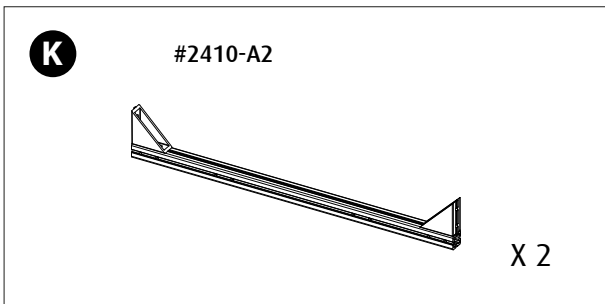
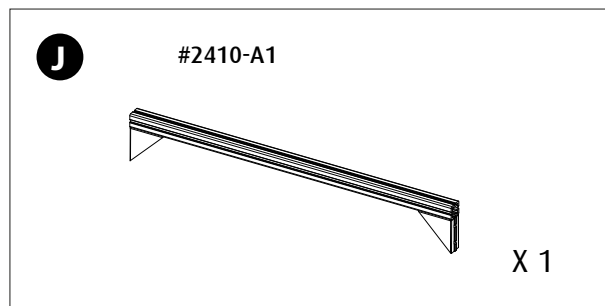
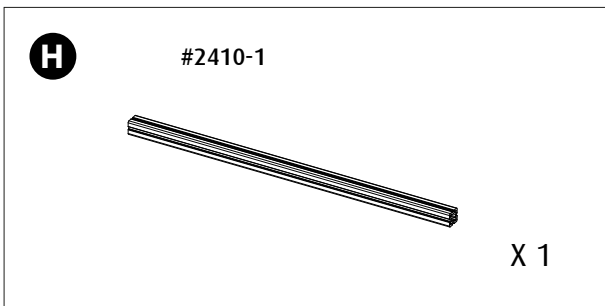

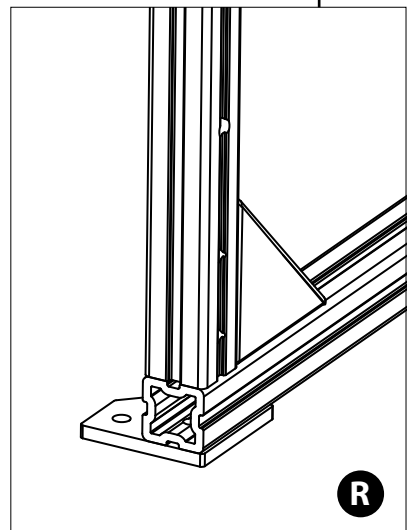
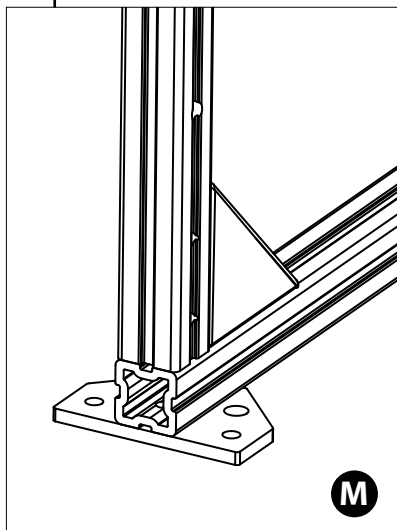
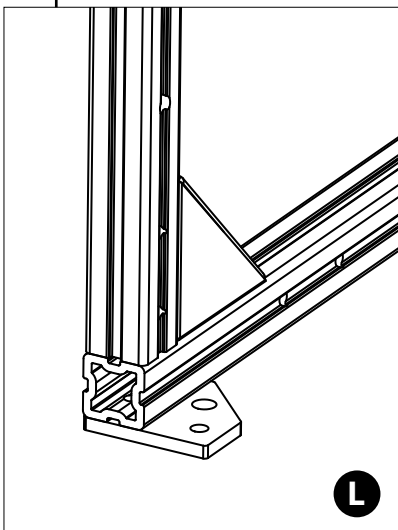
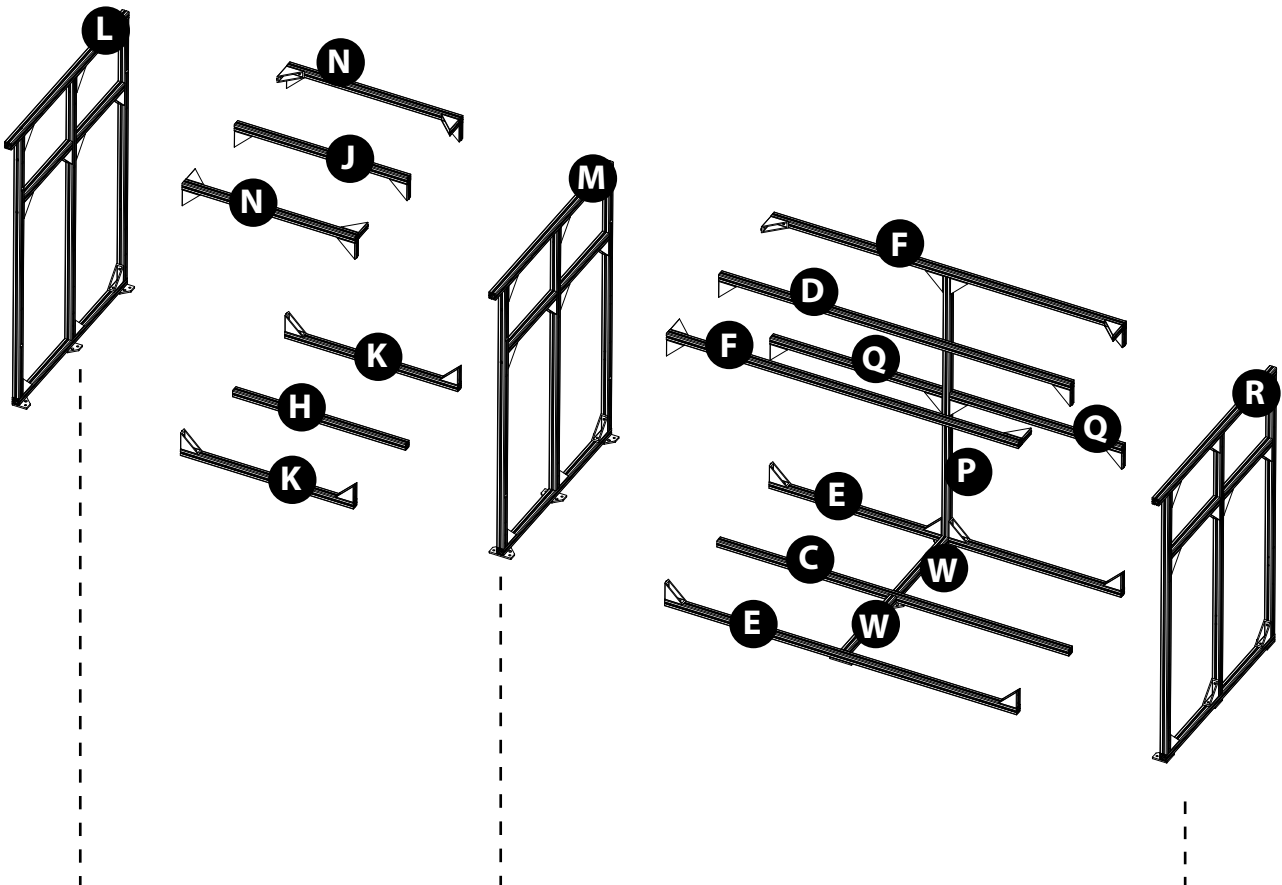
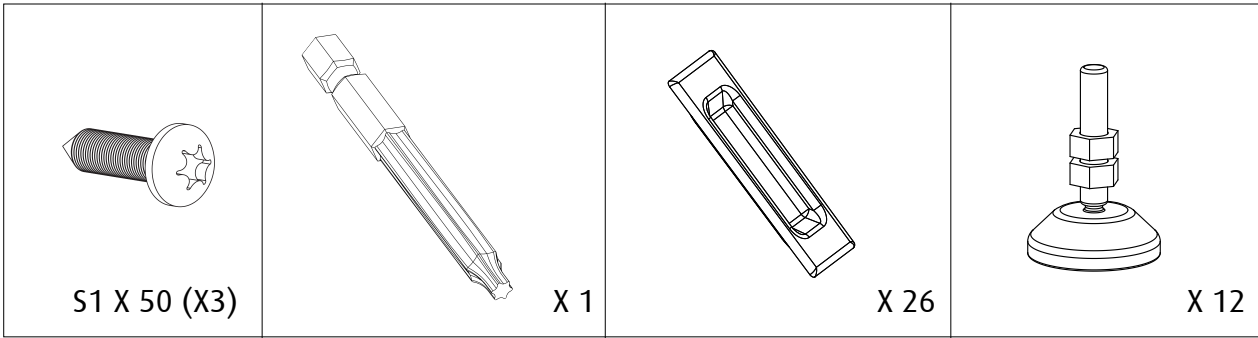

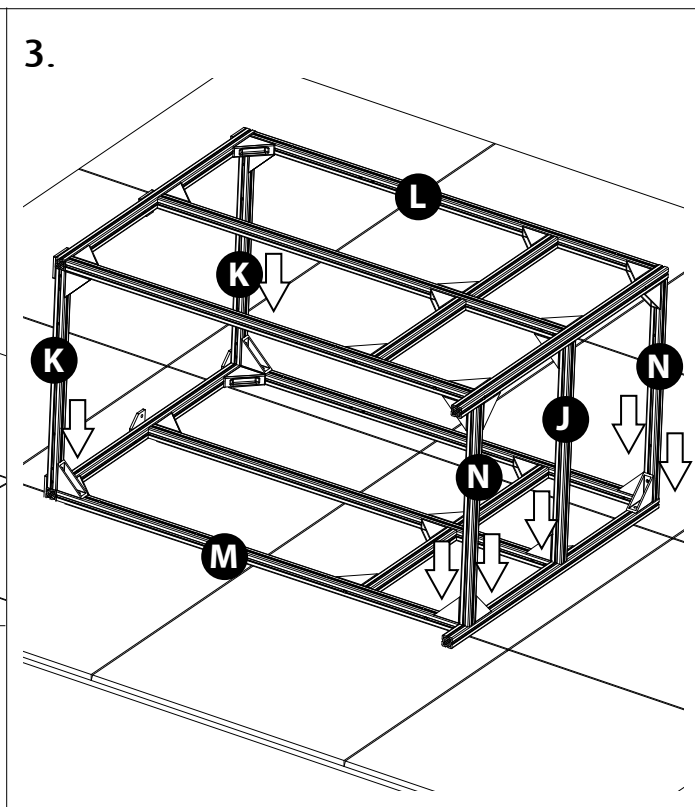
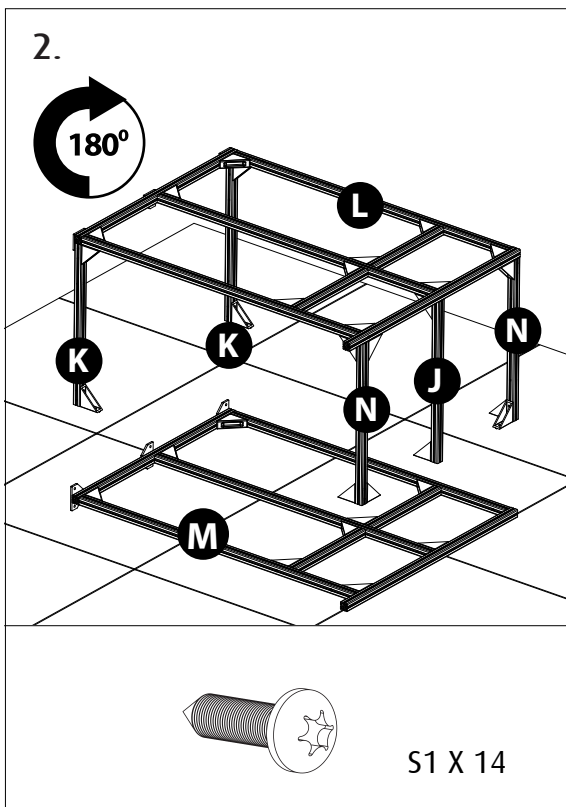
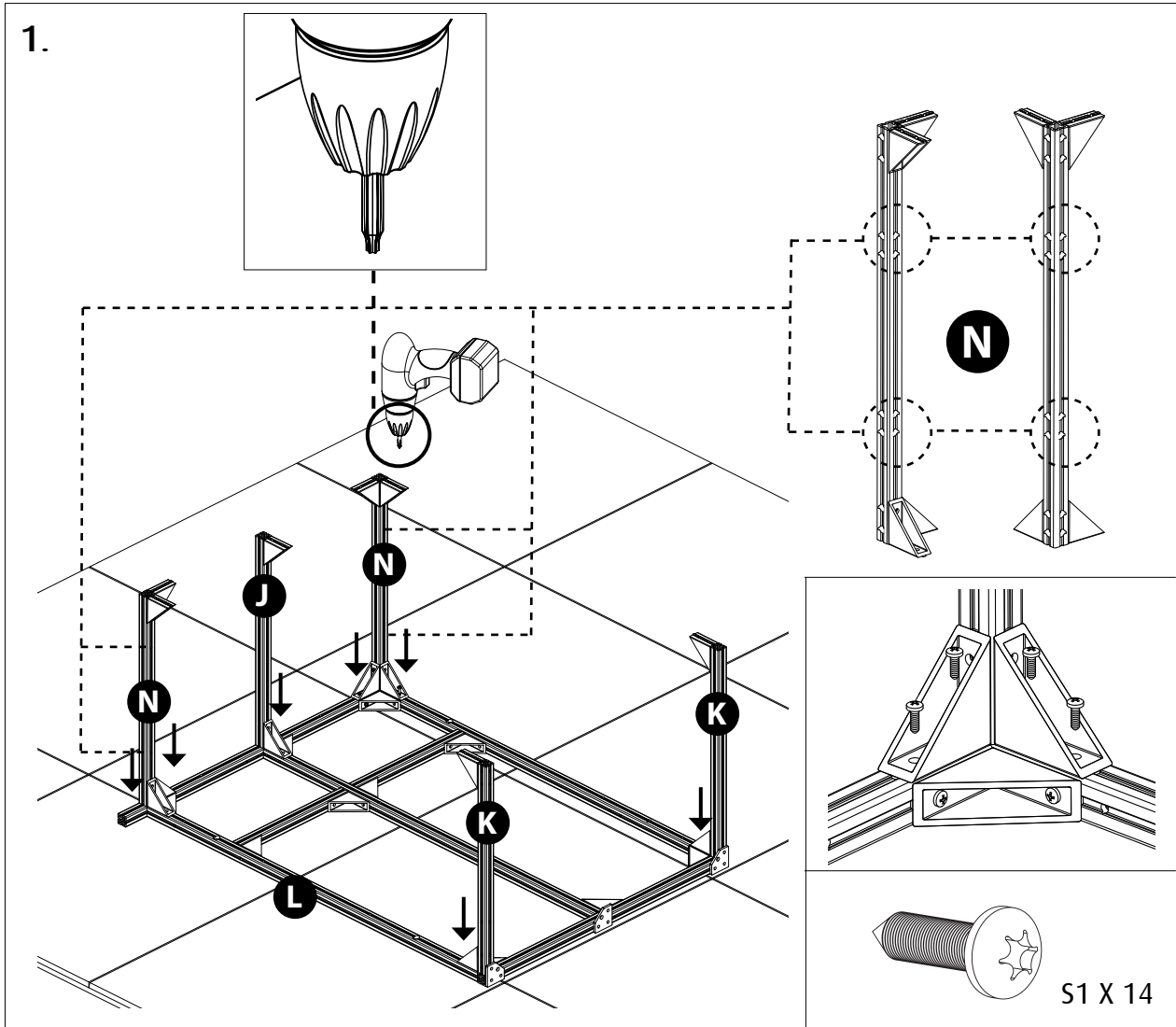

4.

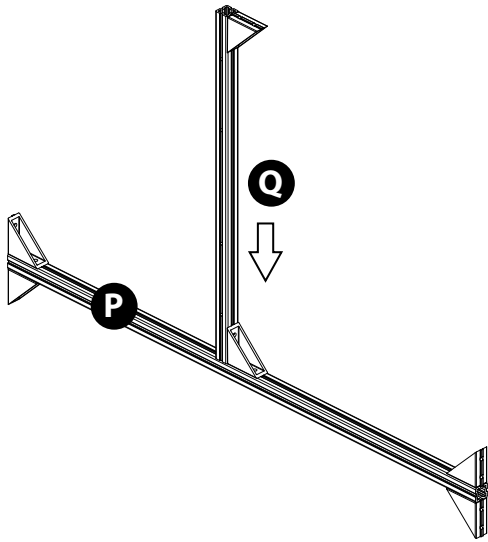

5.

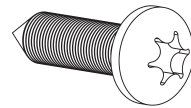
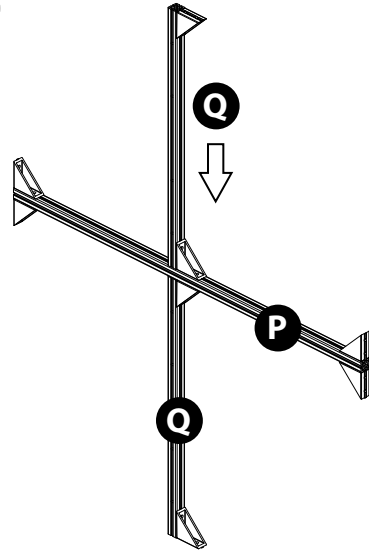
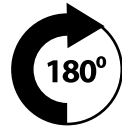

S1 X 4

6.

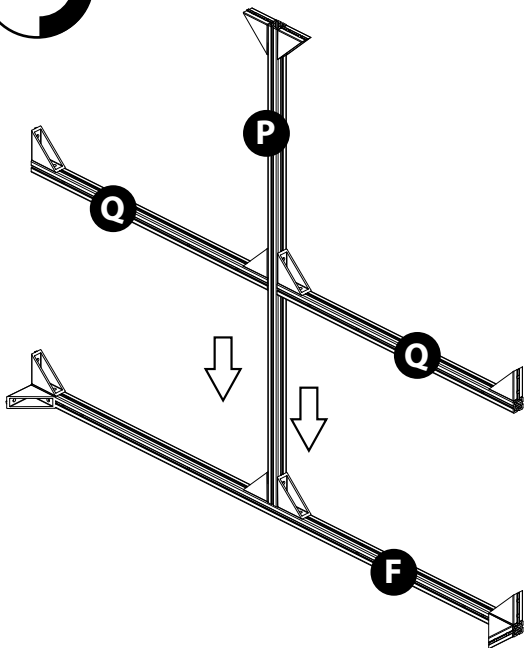
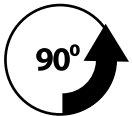

7.

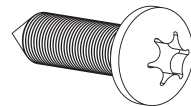
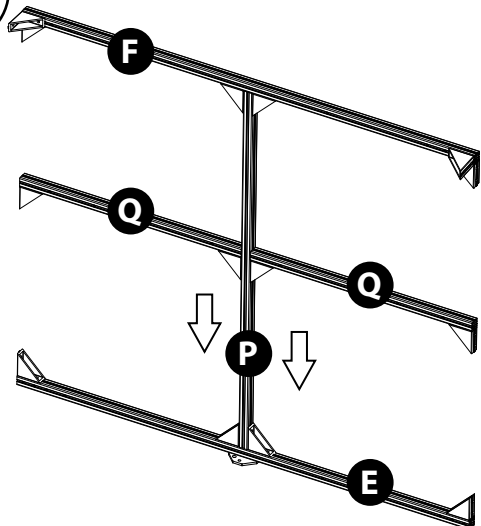
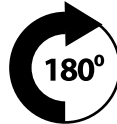

S1 X 8

8.

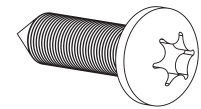
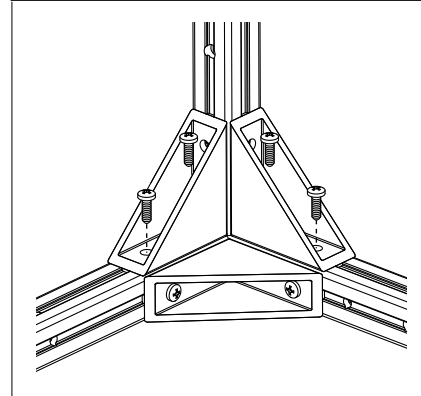
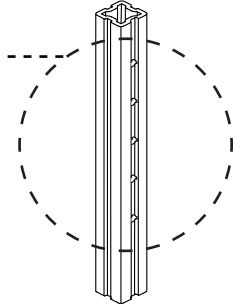
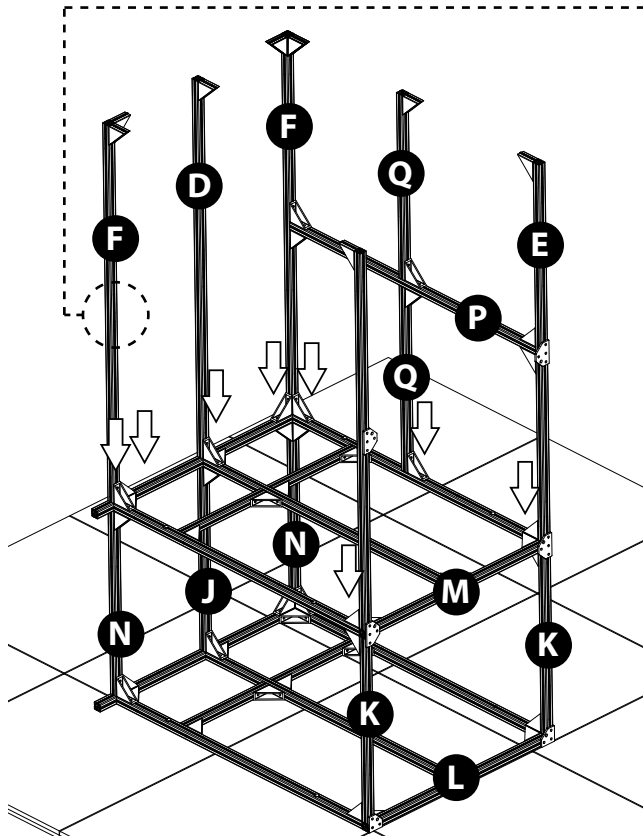

S1 X 16

9.

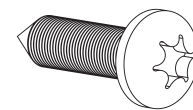
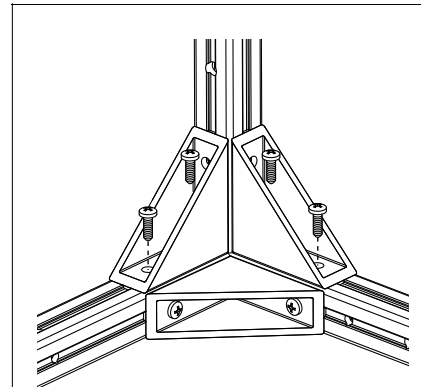
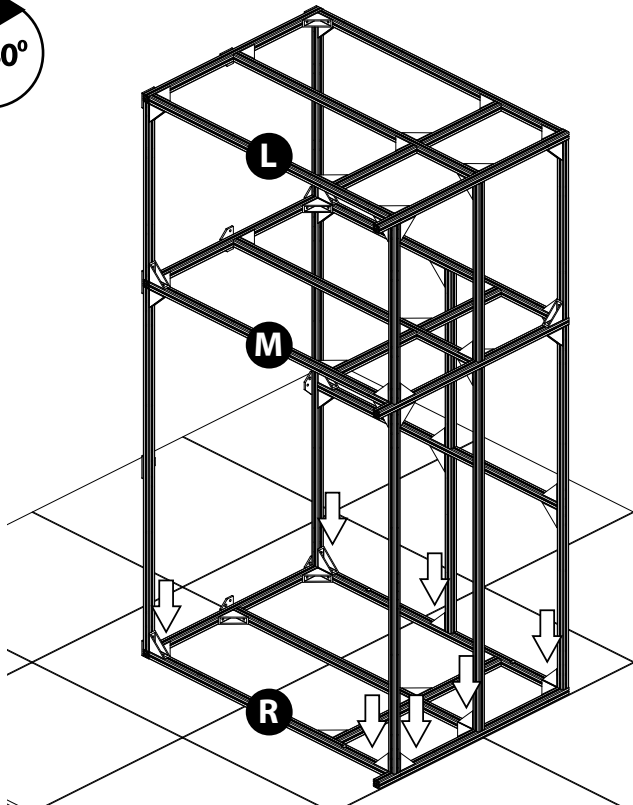
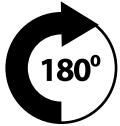

S1 X 14

10.

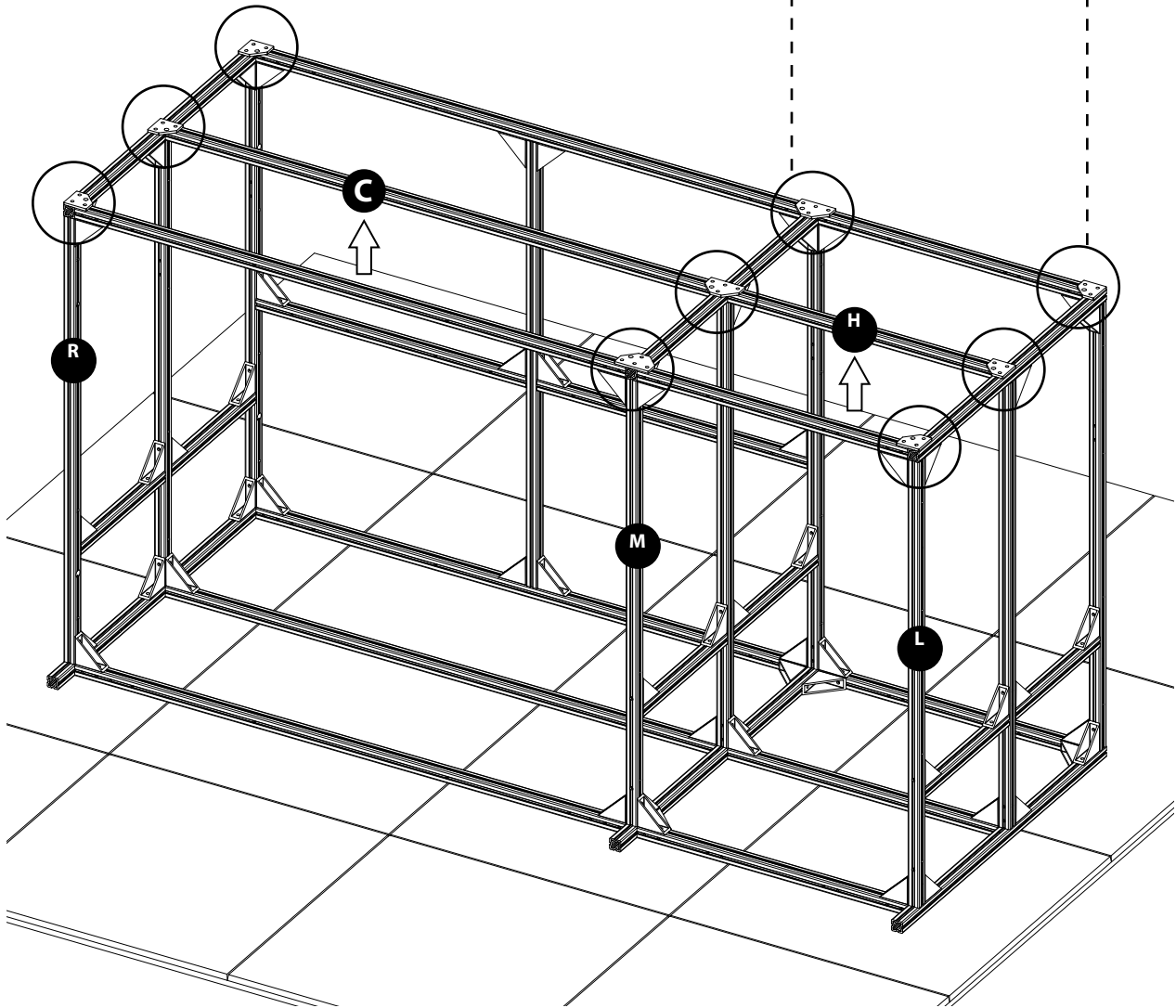
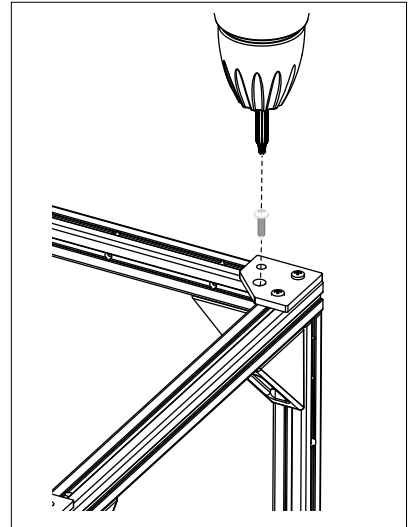
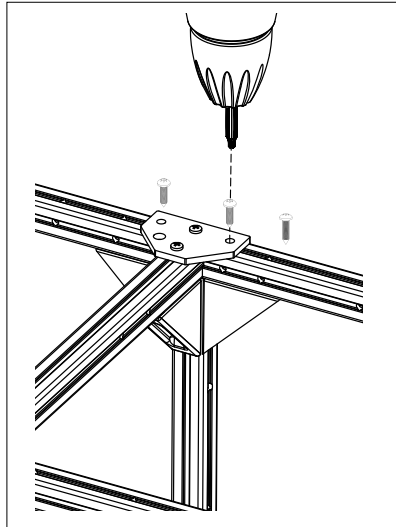
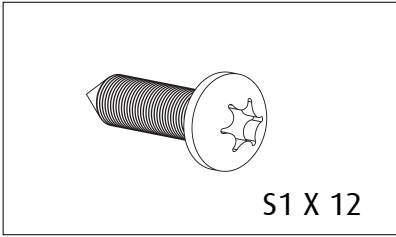

11.

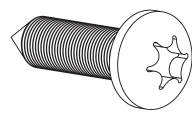
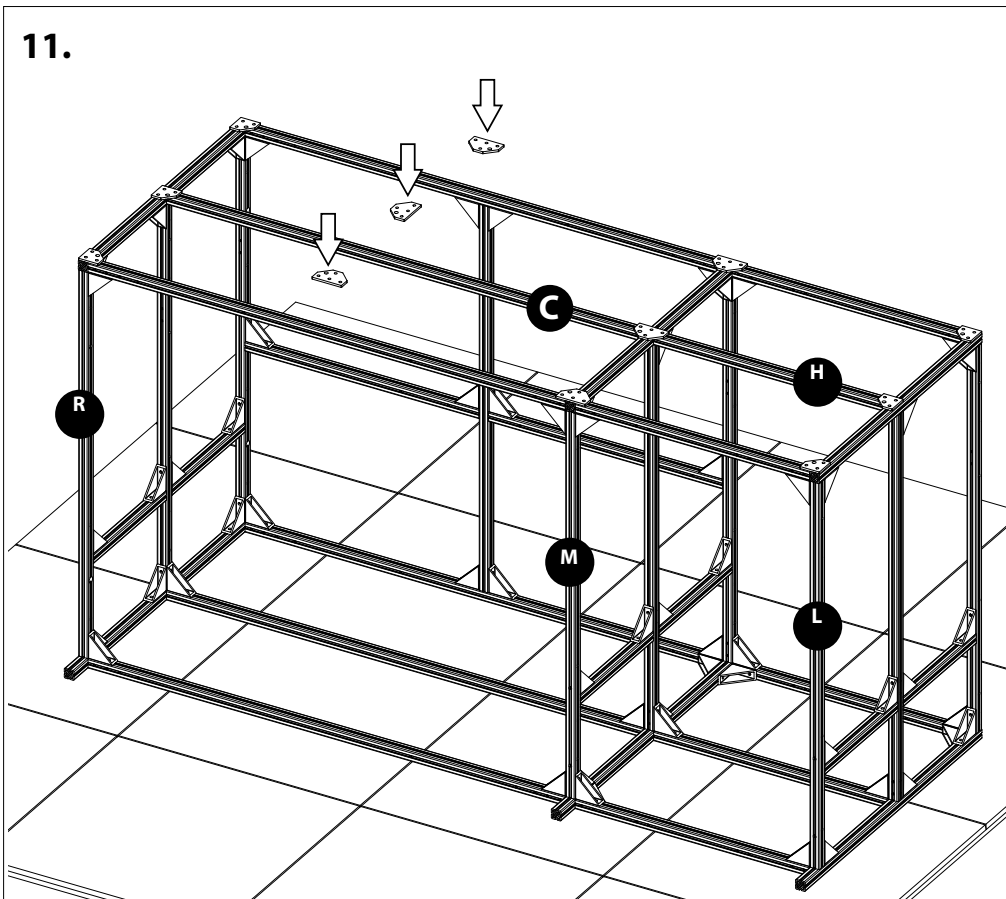

S1 X 9

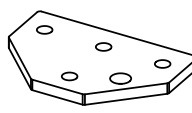

X 3

12.

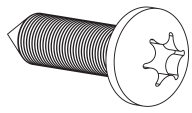
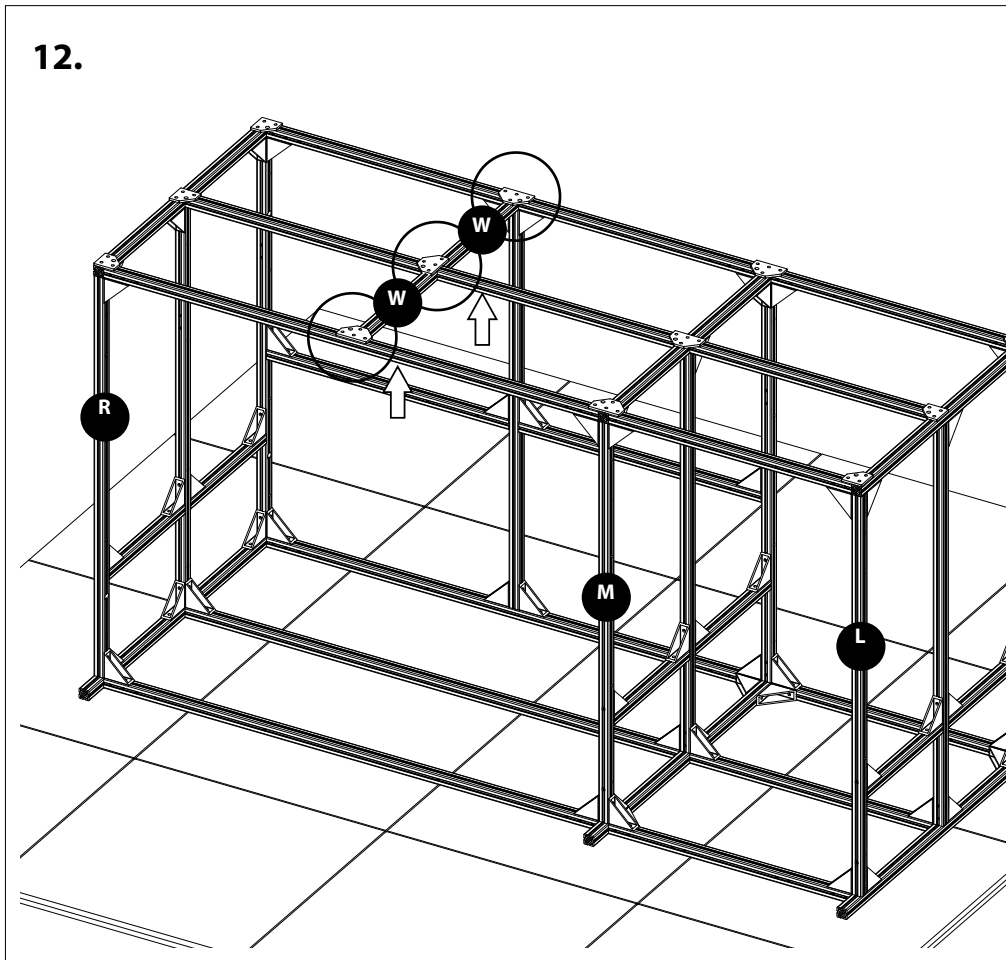

S1 X 4

13.

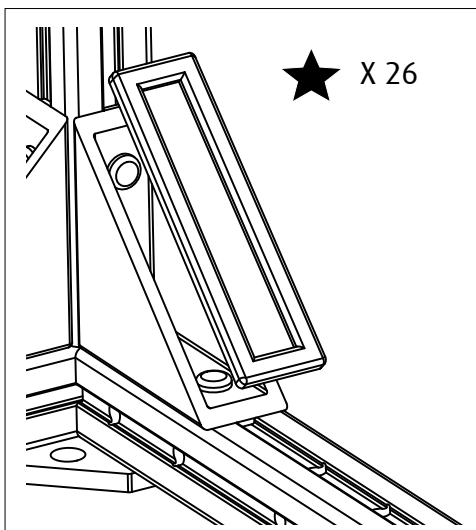
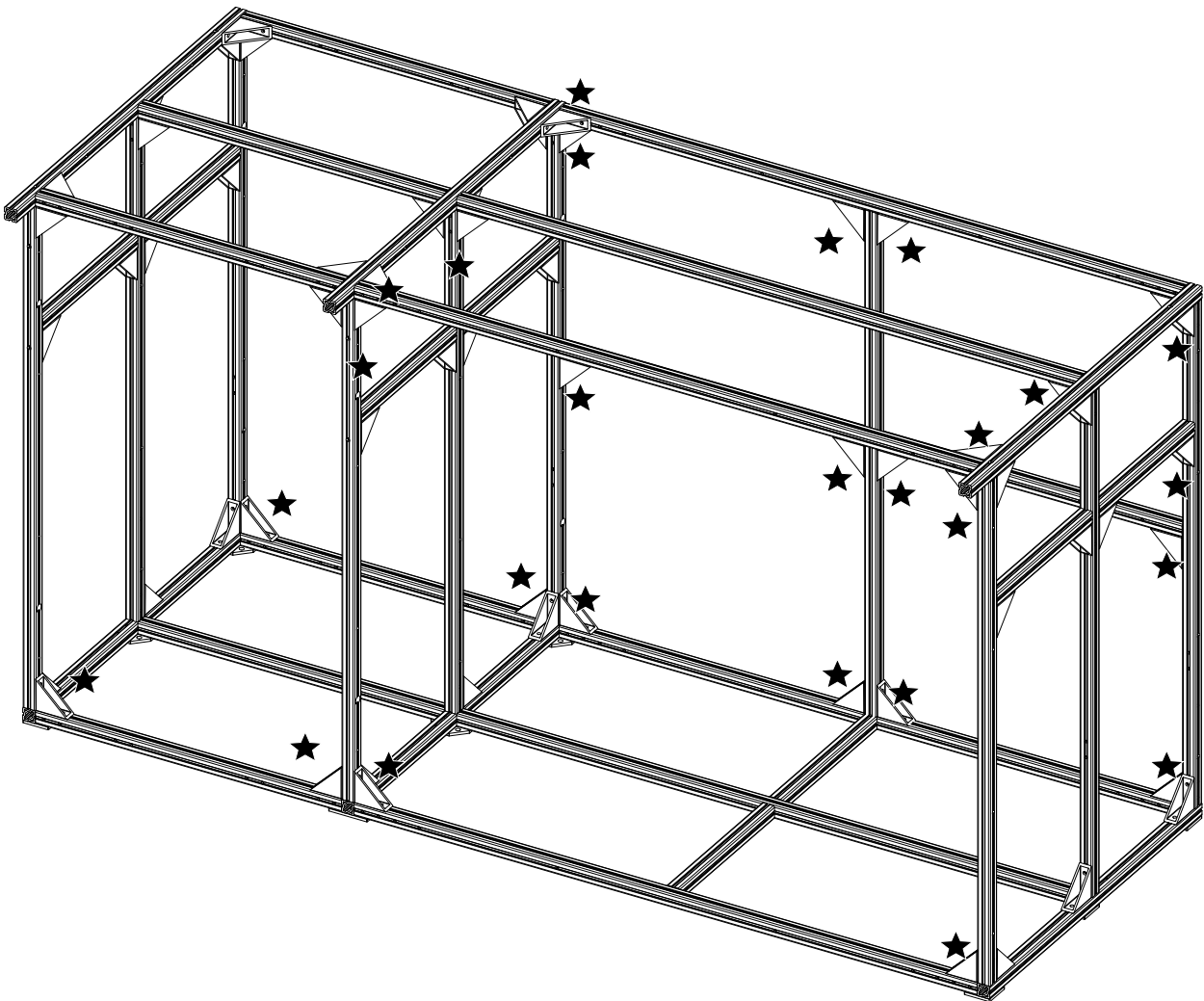

14.

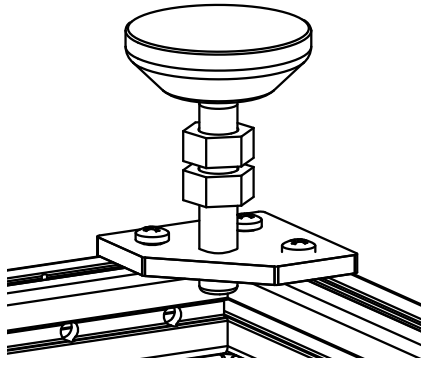

X 4

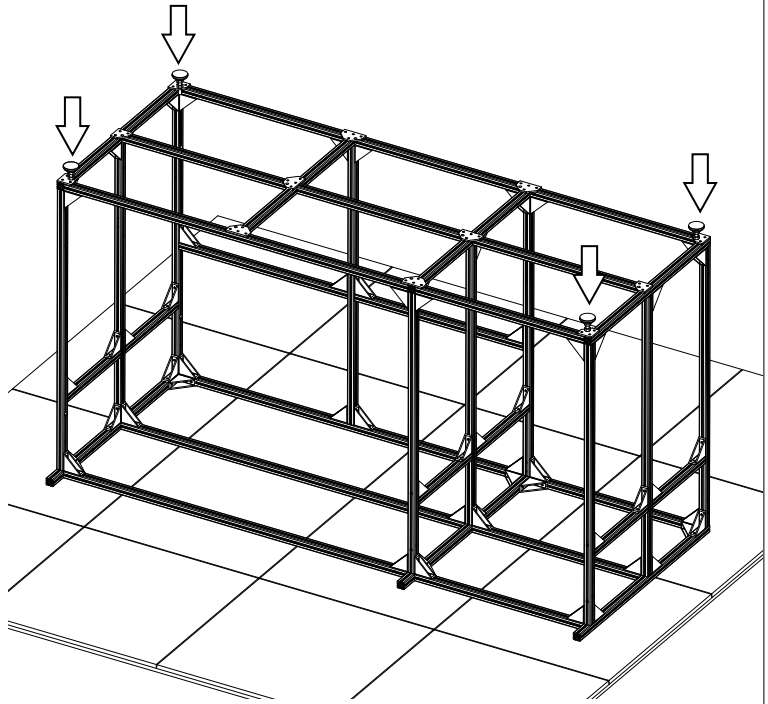

15.

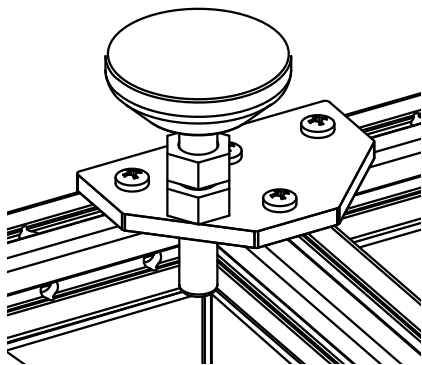

X 8

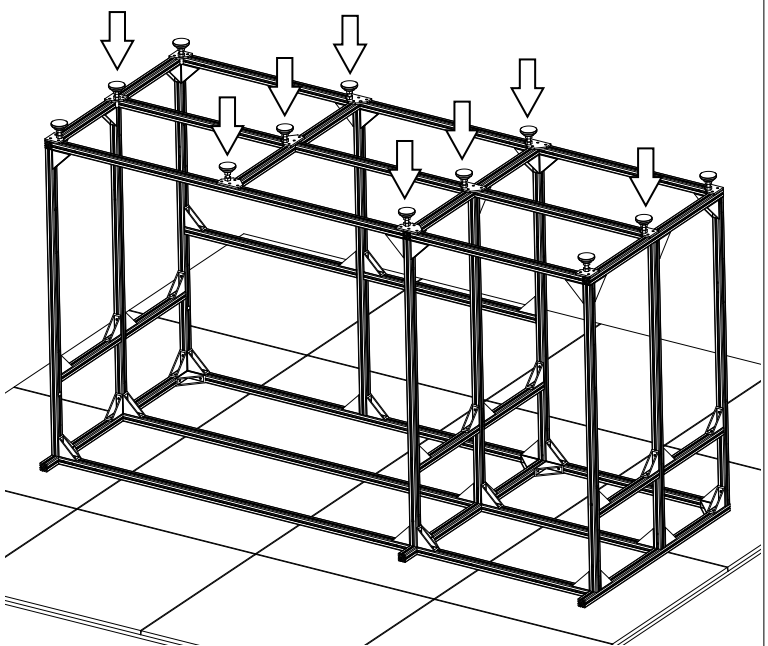

#2

Cabinet | Unterschrank

Meuble | 底柜

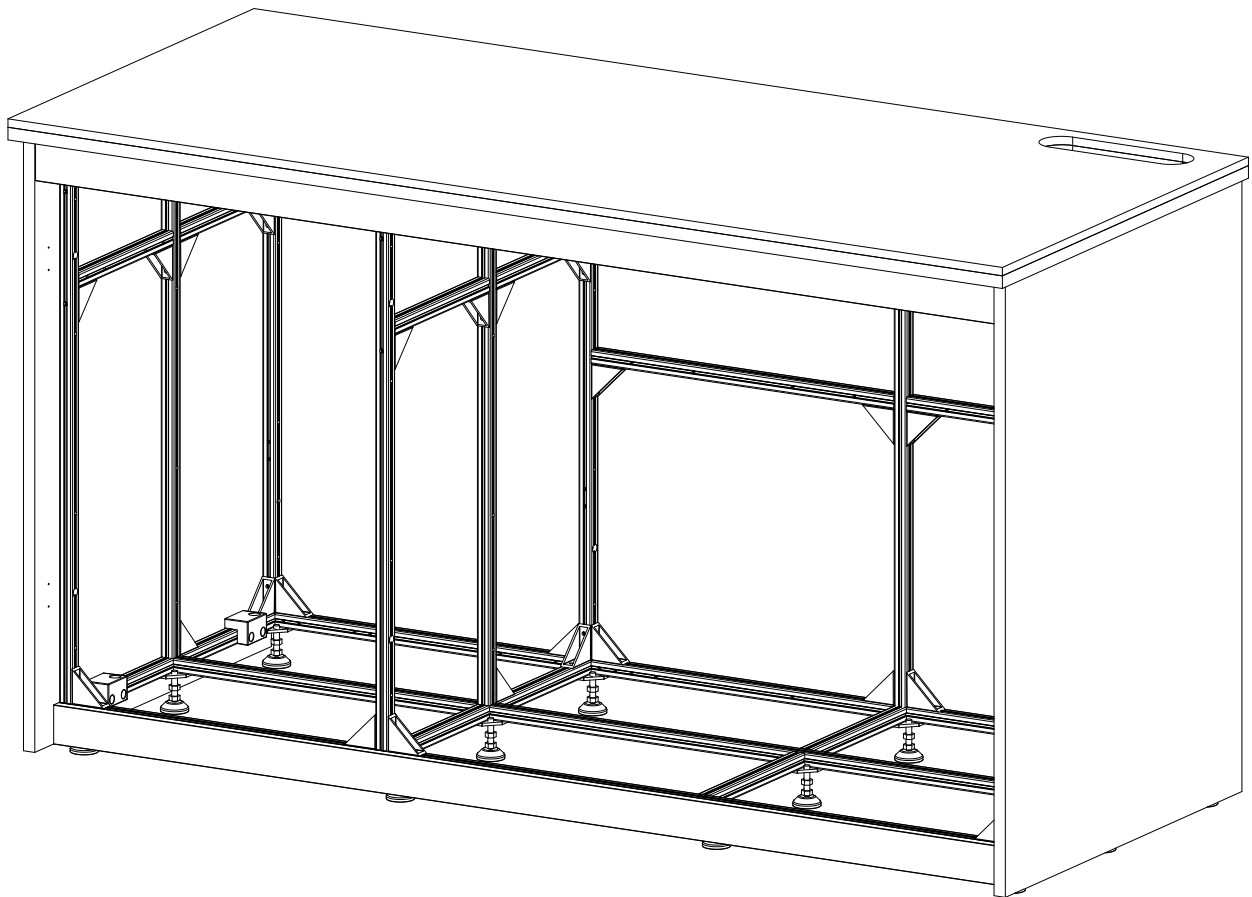

Parts | Teile | Éléments | 部品

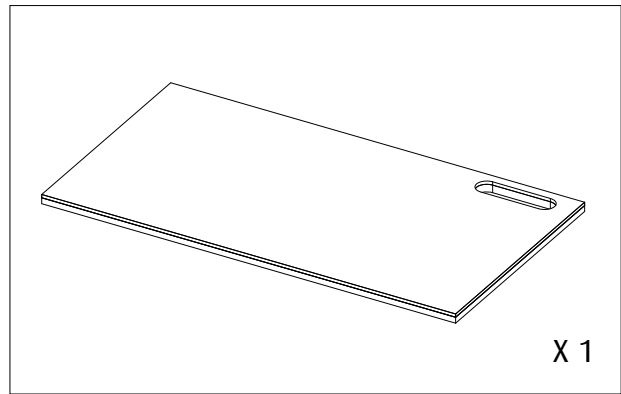
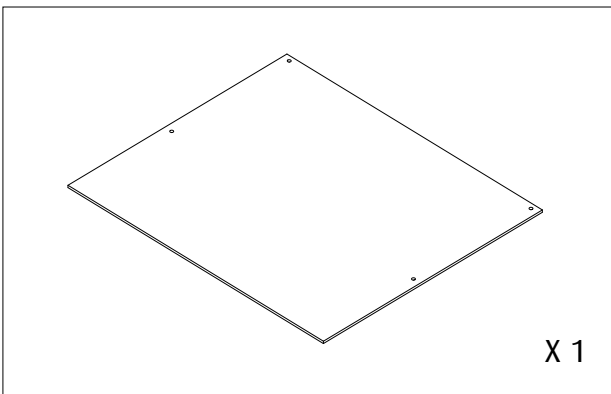
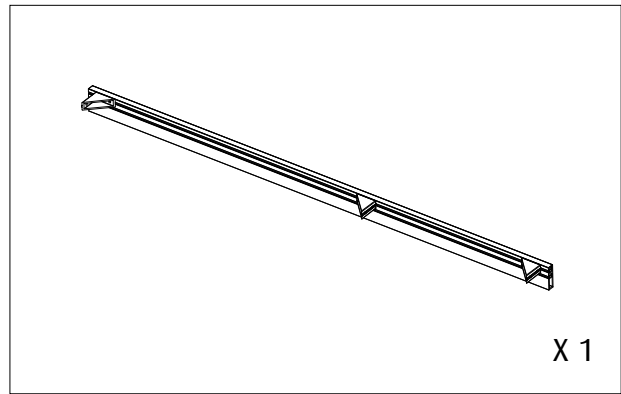
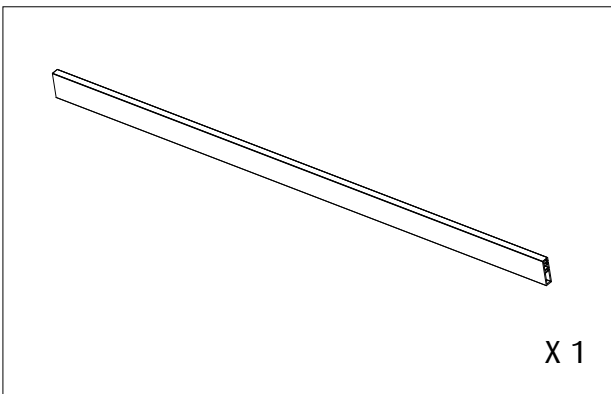
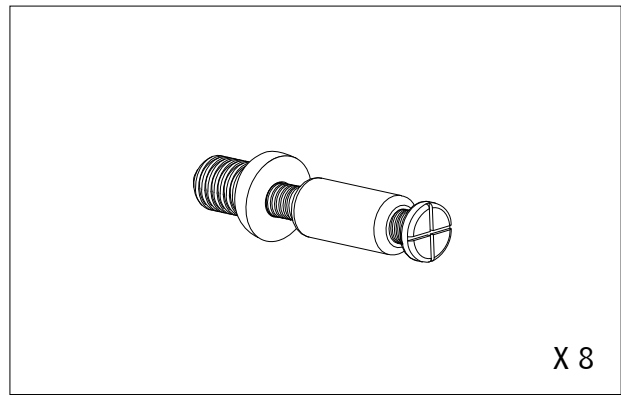
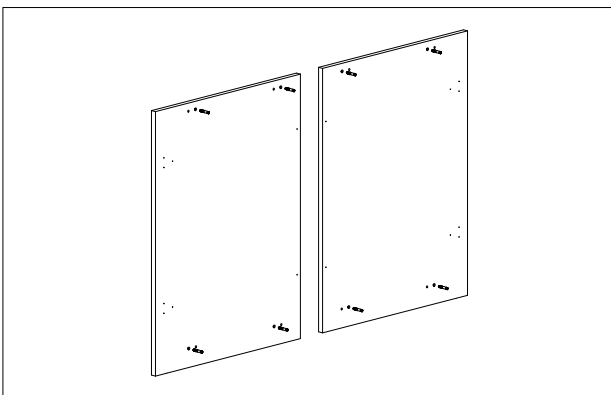
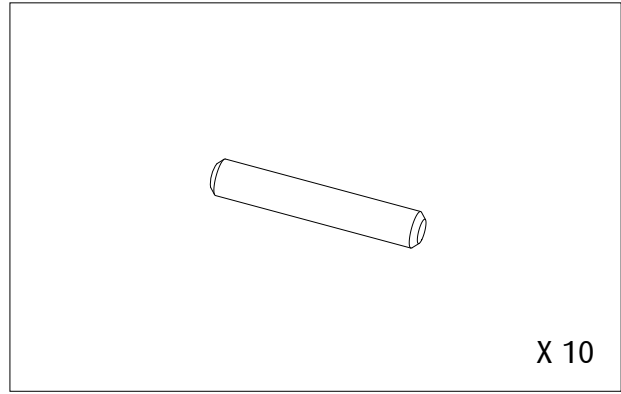
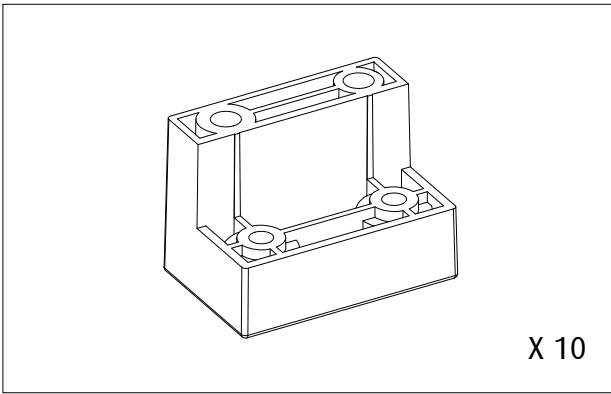

1.

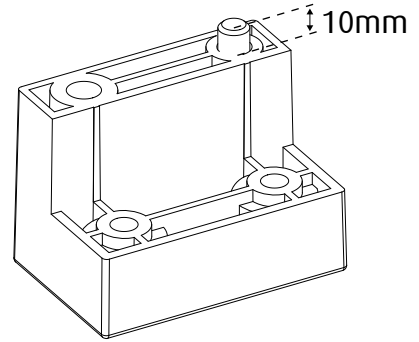
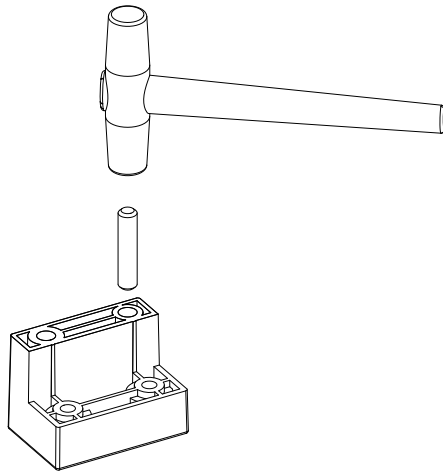

X 10

2.

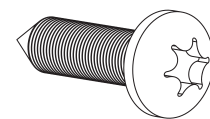
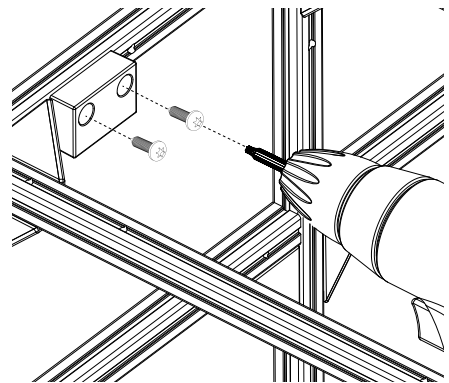
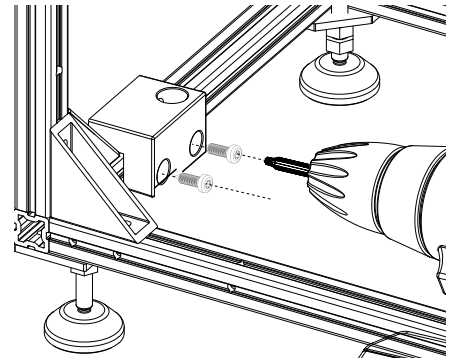
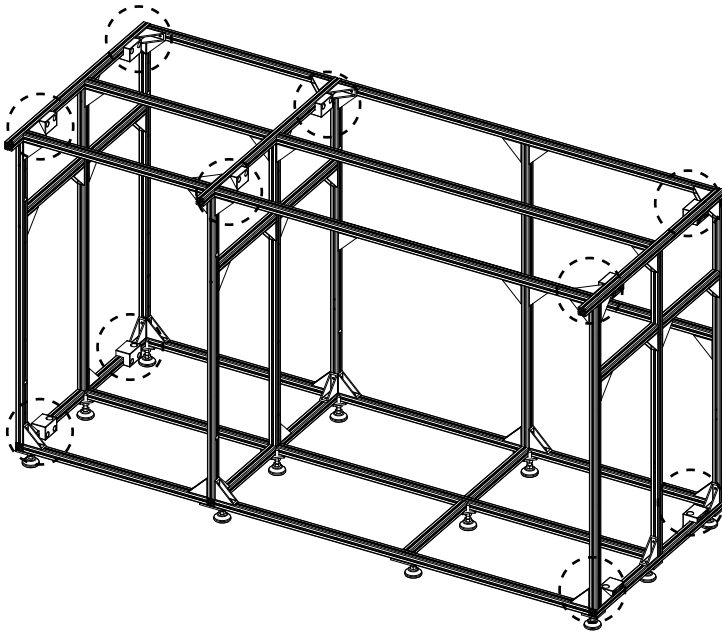

S1 X 20

3.

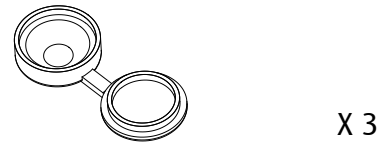
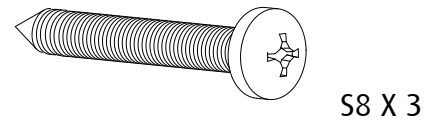
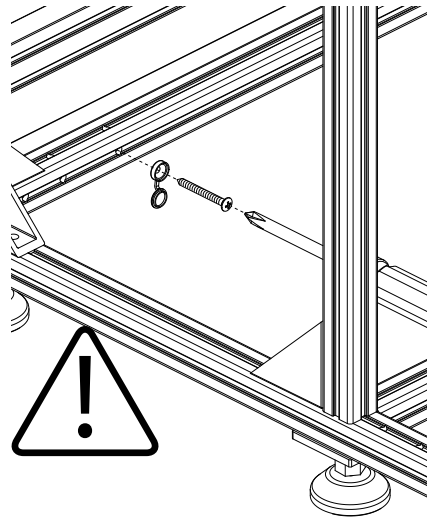
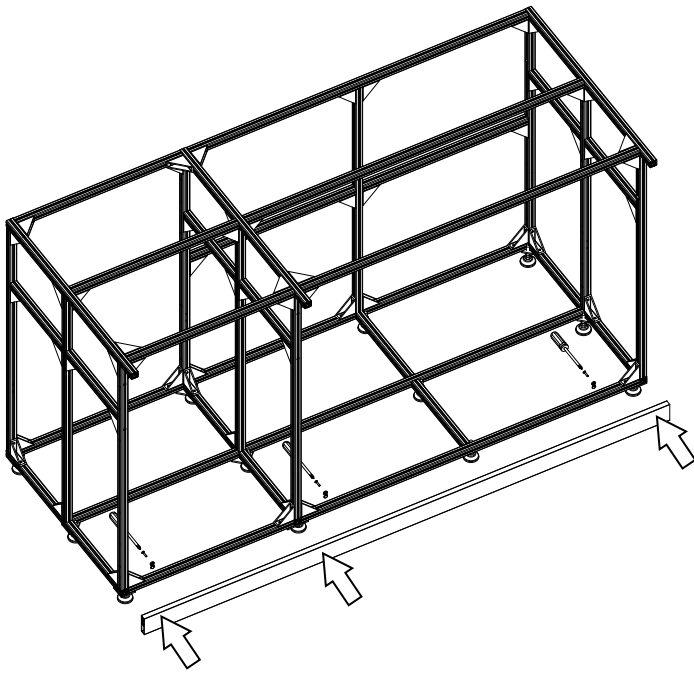

4.

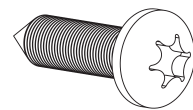
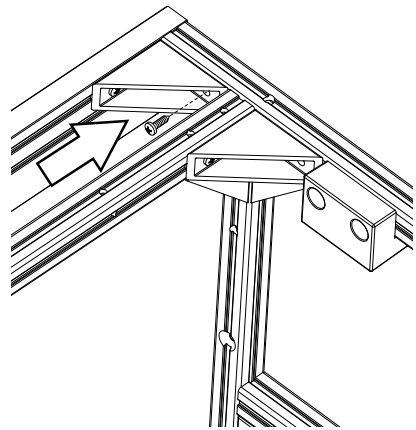
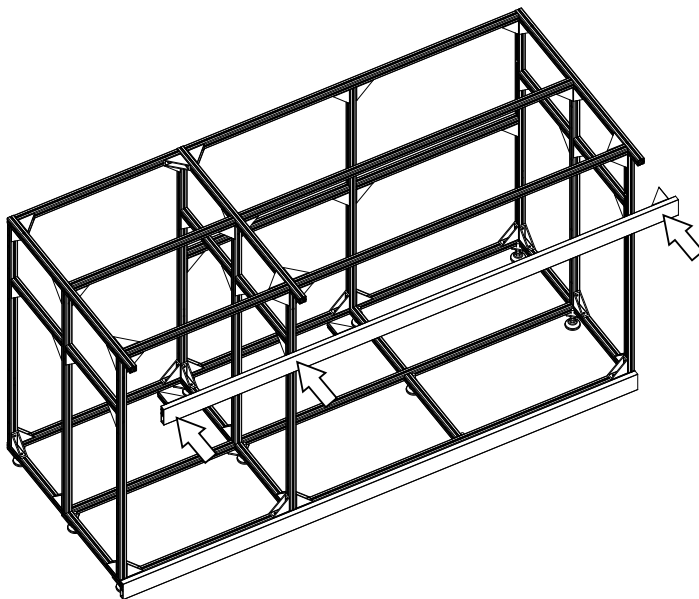
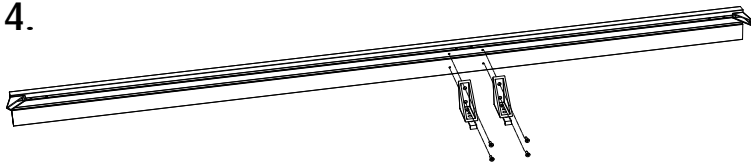

S1 X 3

5.

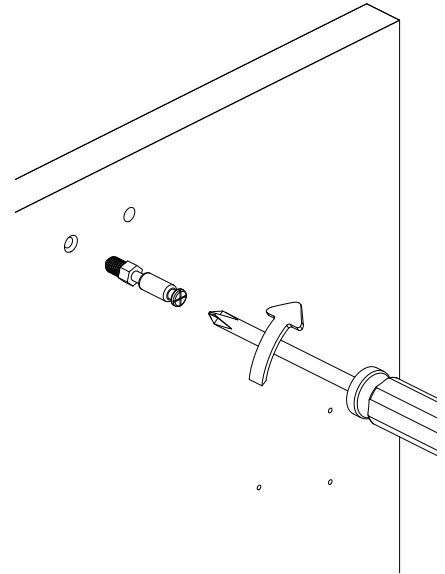
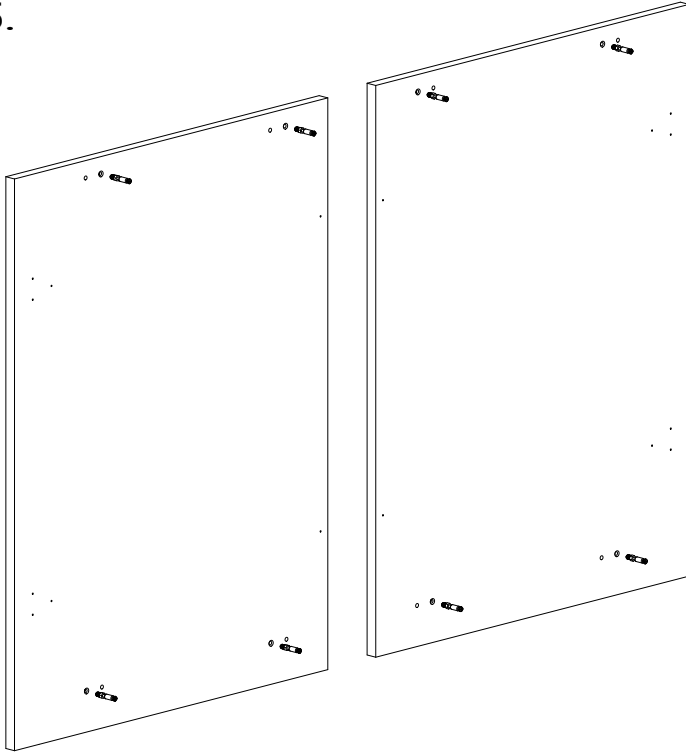

X 8

6.

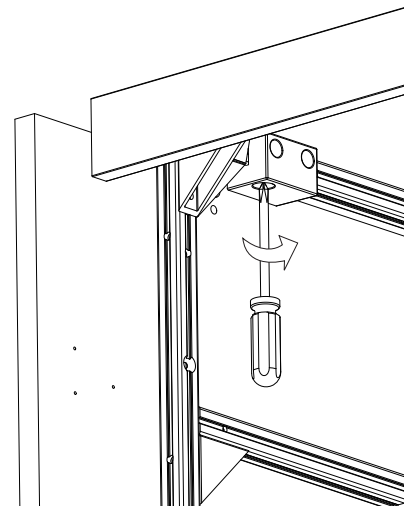
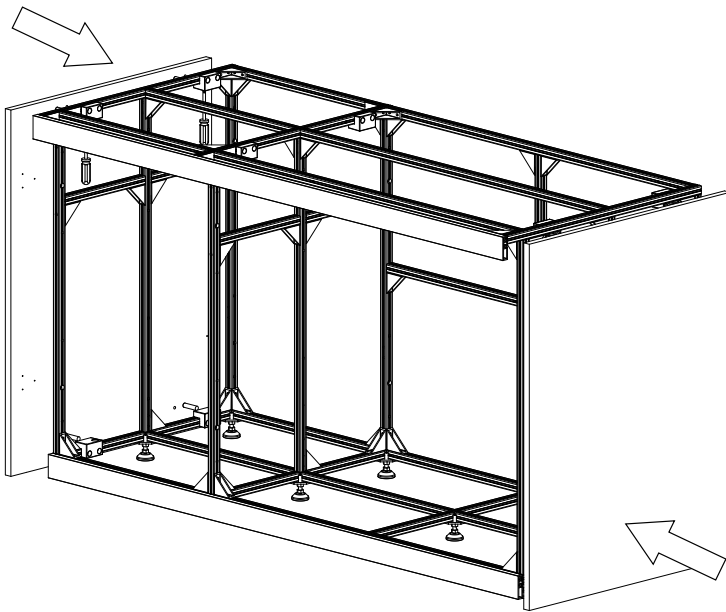

X 8

7.

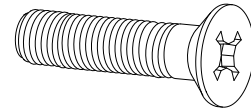
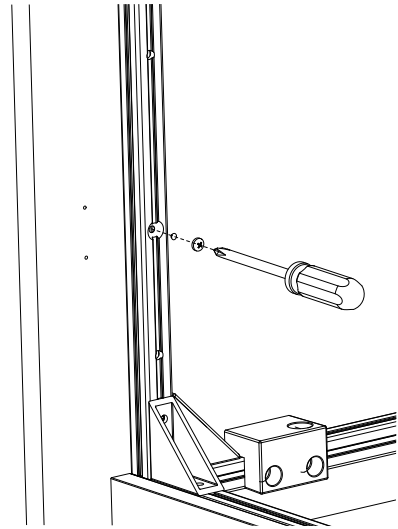
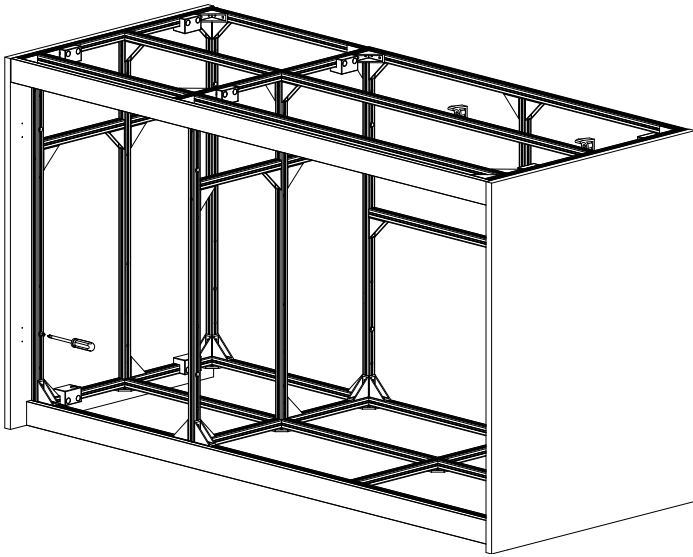

S4 X 8

8.

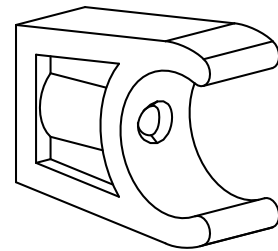
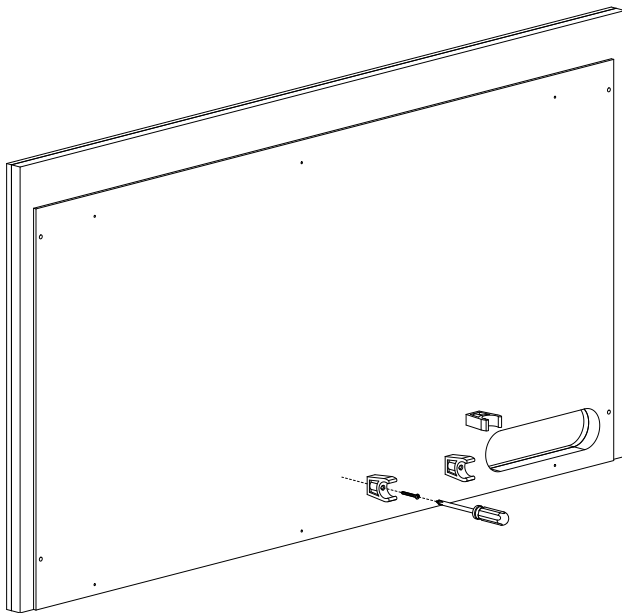

X 3

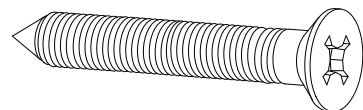

S3 X 3

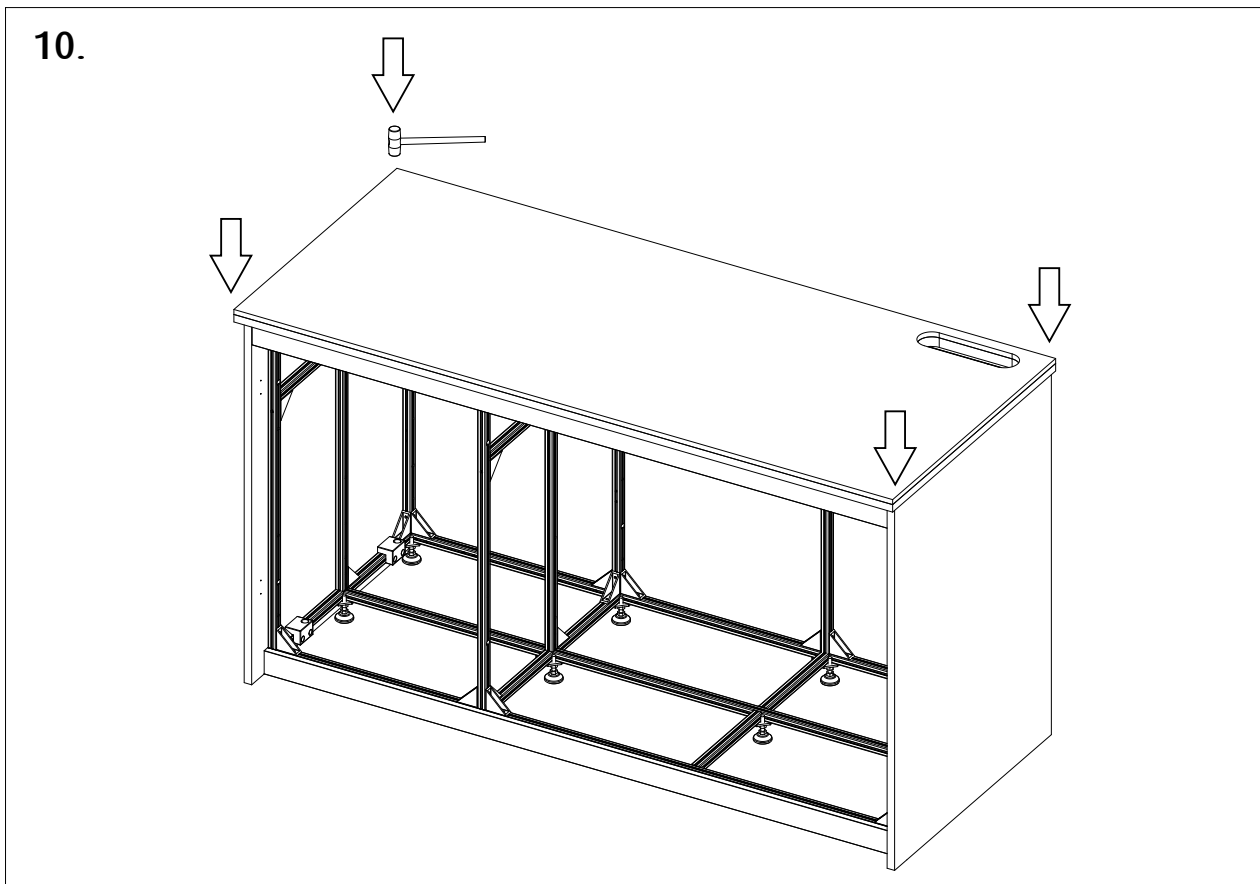
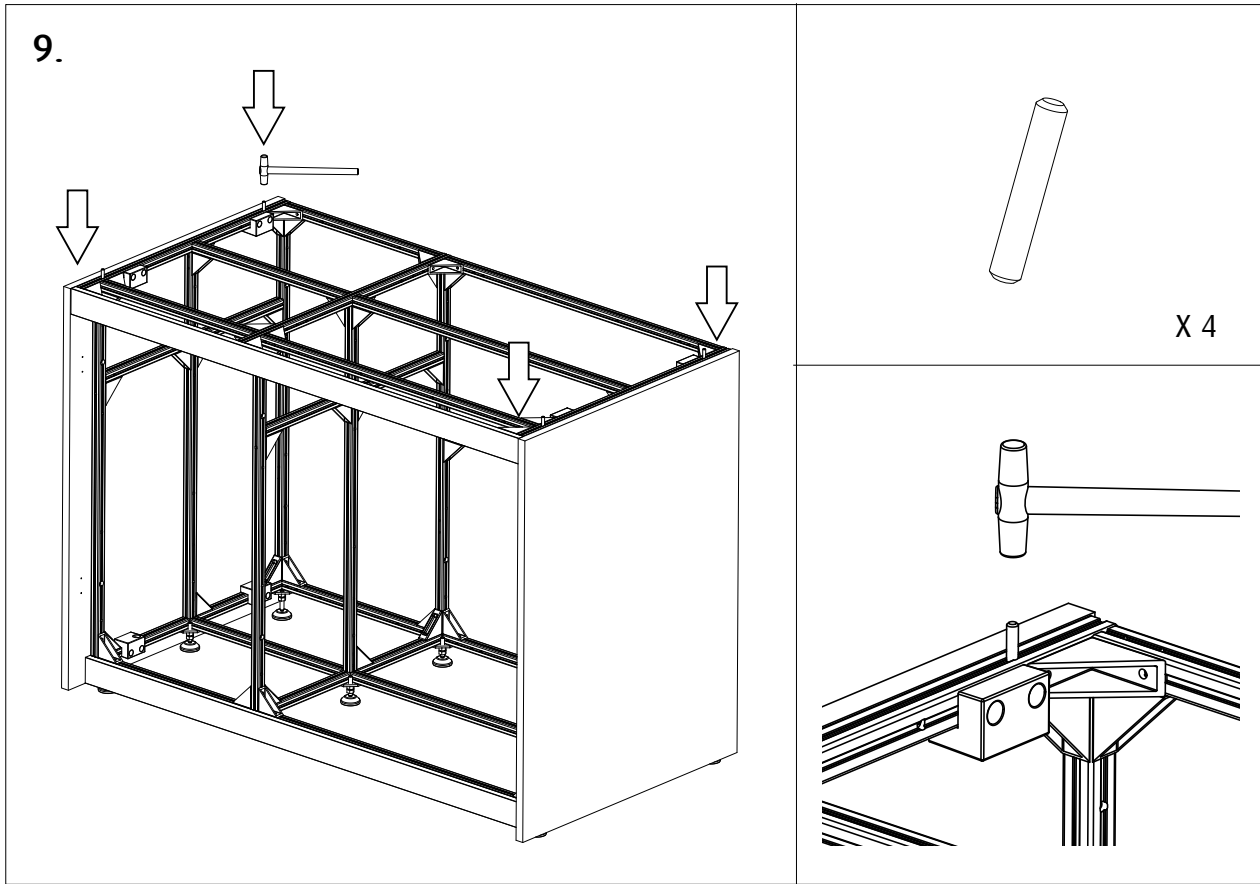

11.

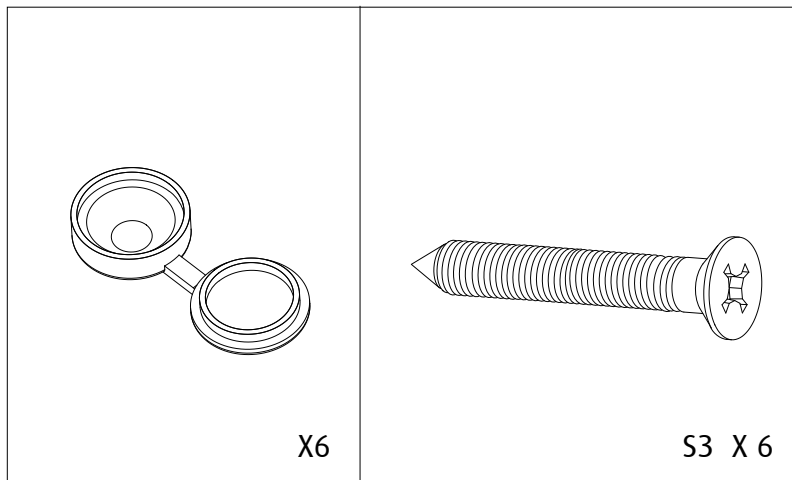
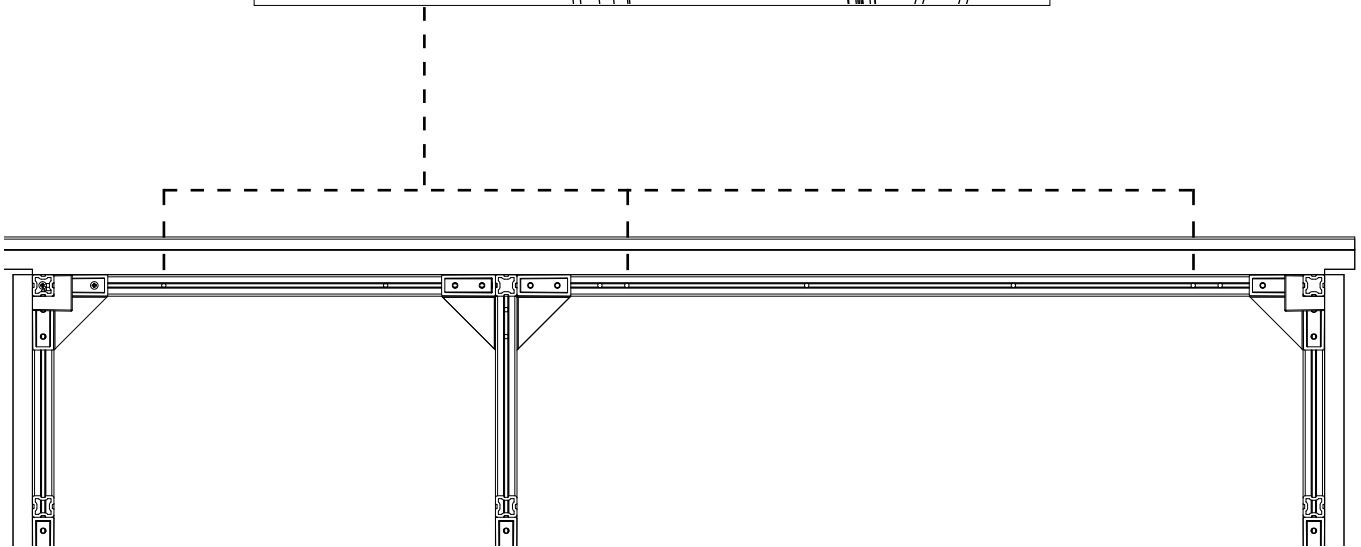
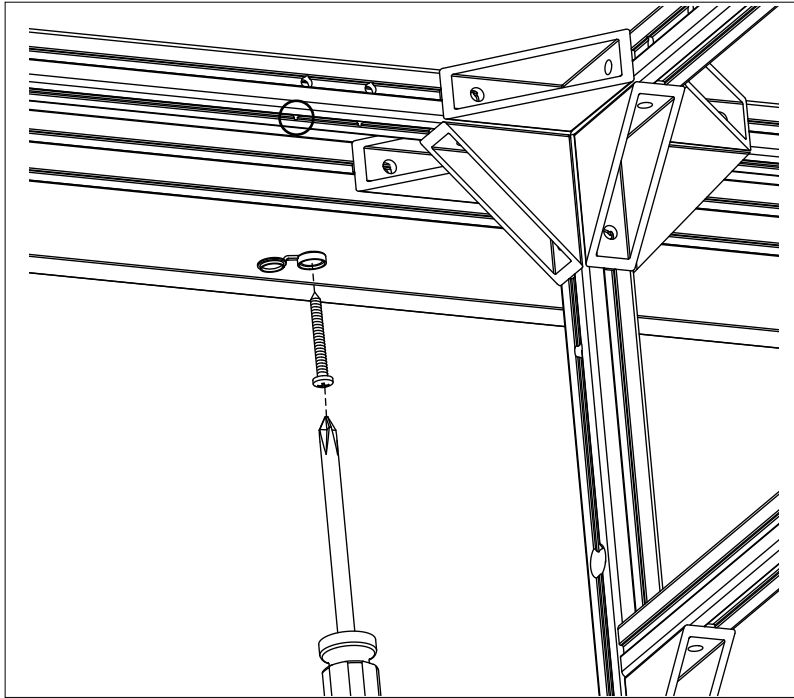

12.

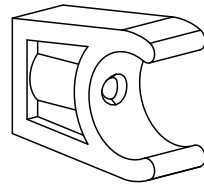
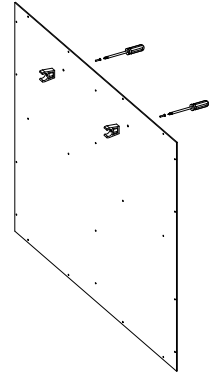
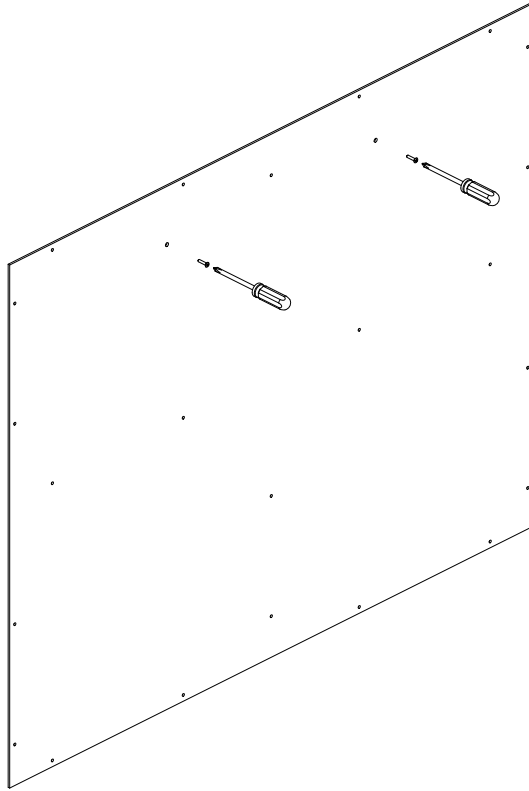

X 2

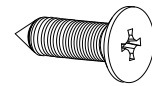

S5 X 2

13.

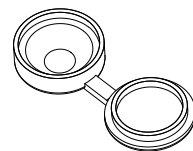
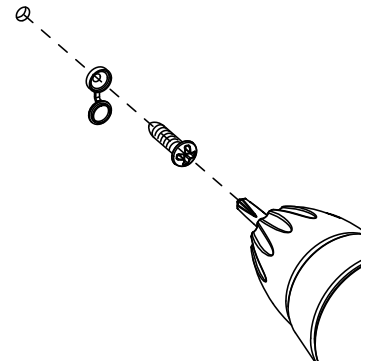
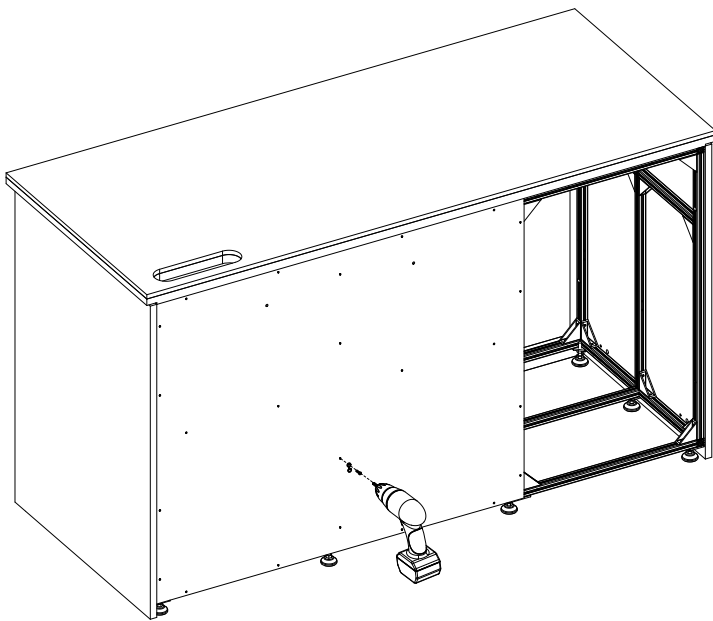

X 24

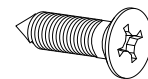

S2 X 24

#3

Positioning | Ausrichtung
Emplacement | 擺放位置

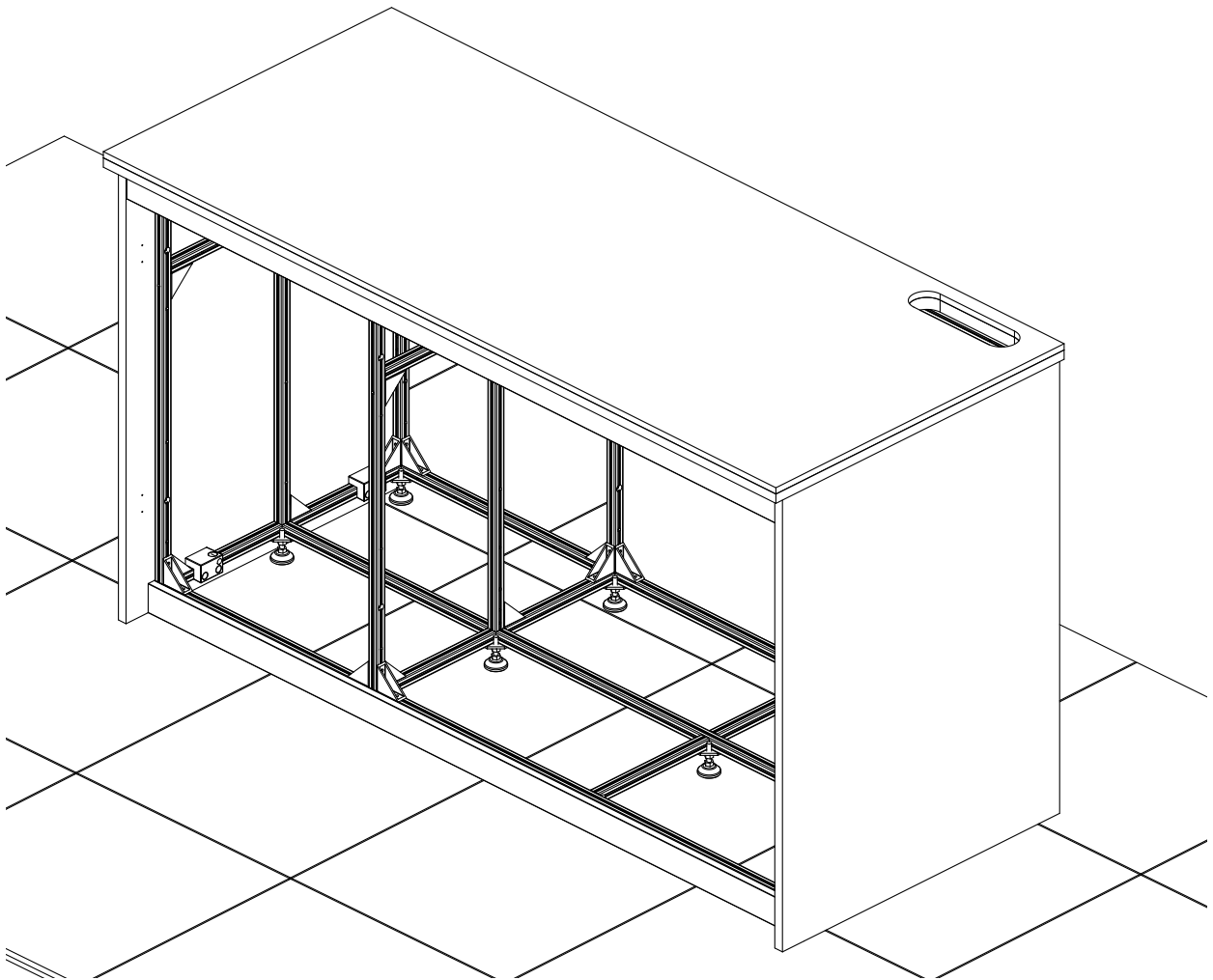

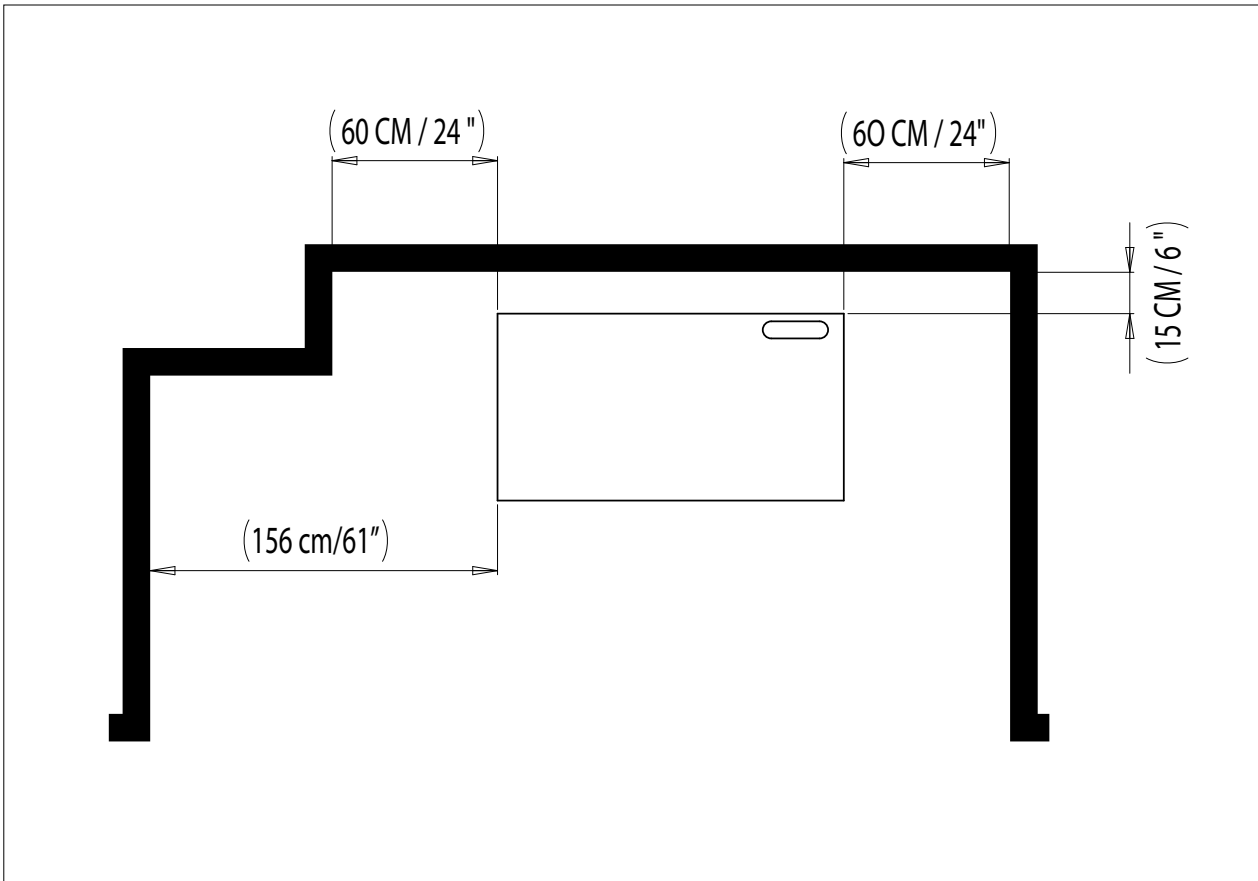
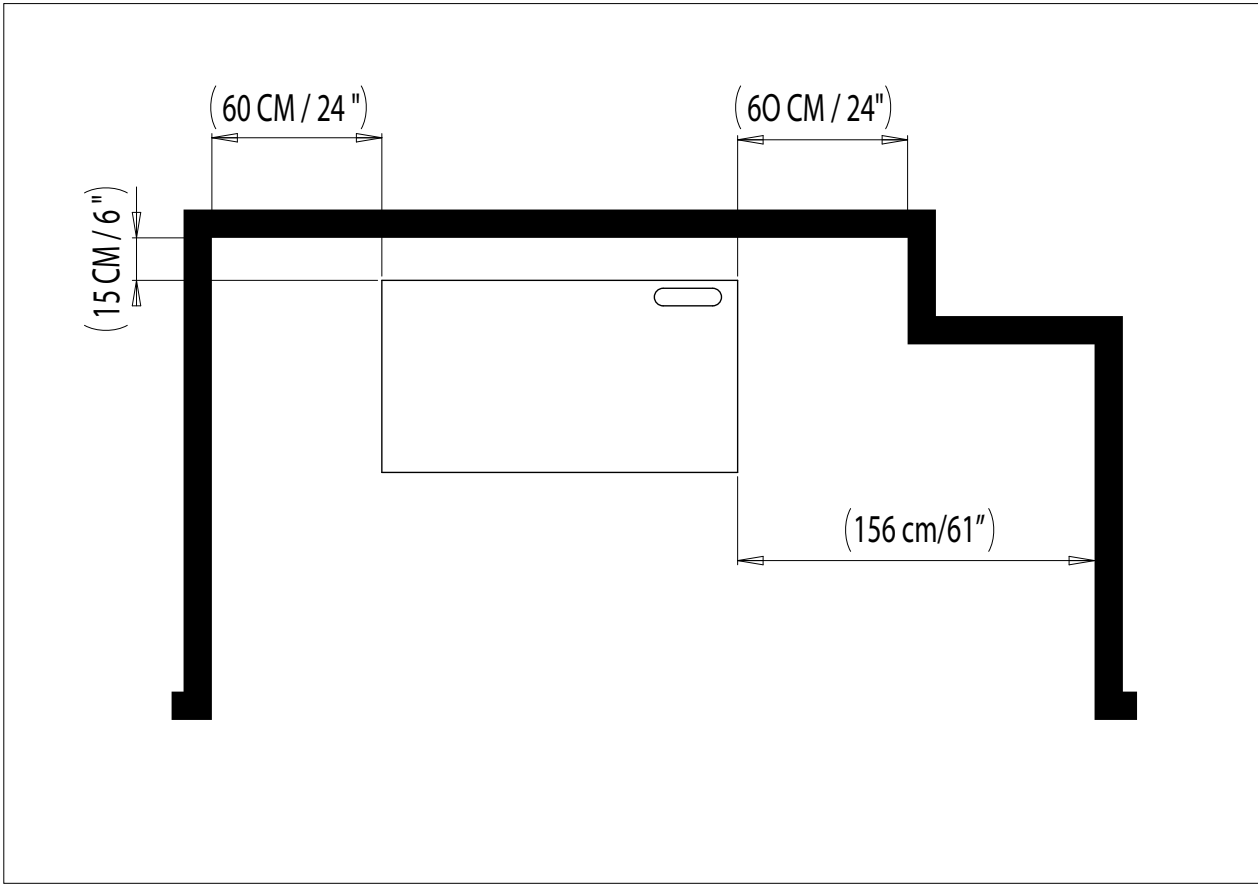

#4

Aquarium & Sump | Aquarium & Filtersumpf
Aquarium et decantation | 水族箱和过滤缸

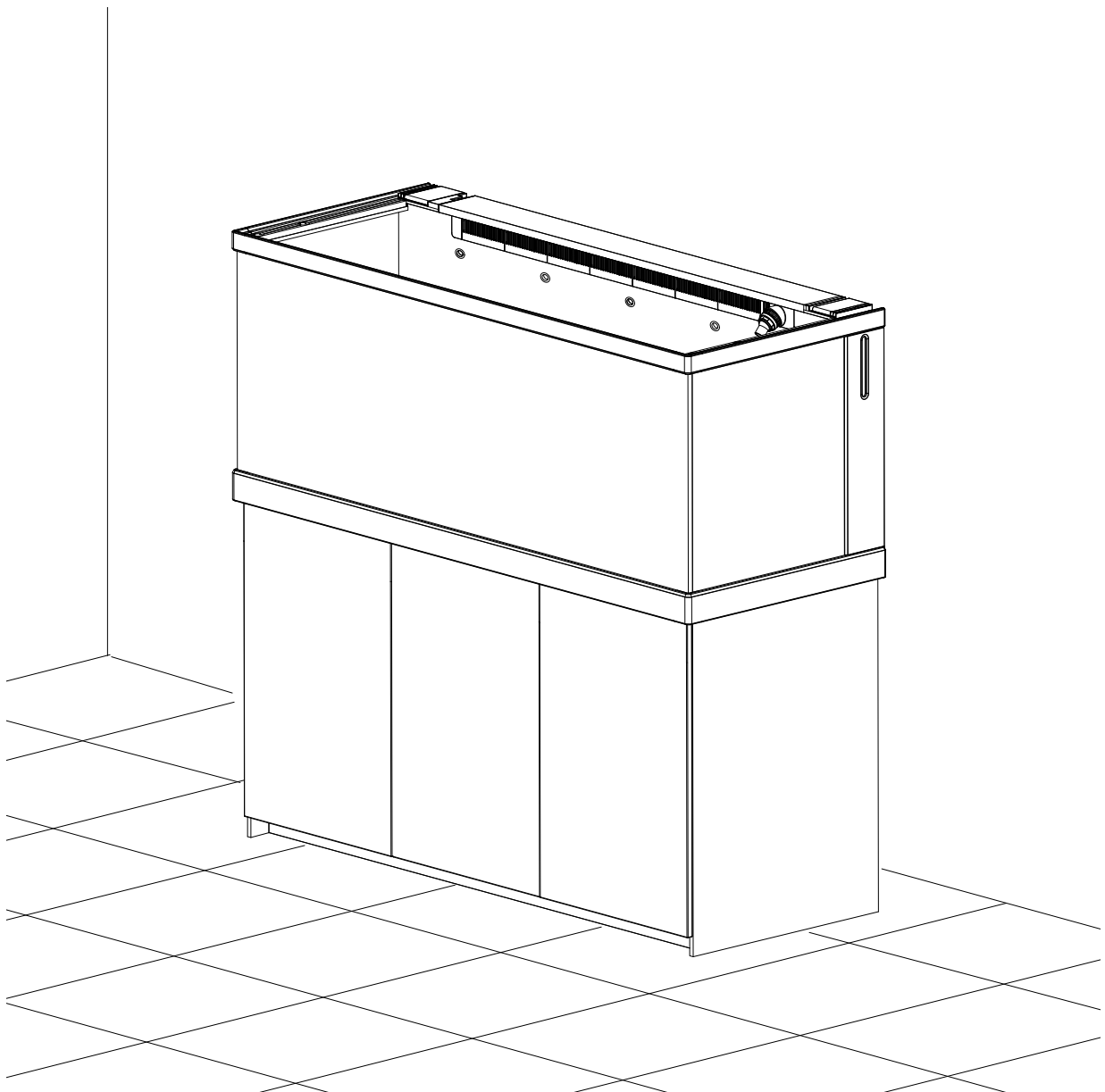

Parts | Teile | Éléments | 部件

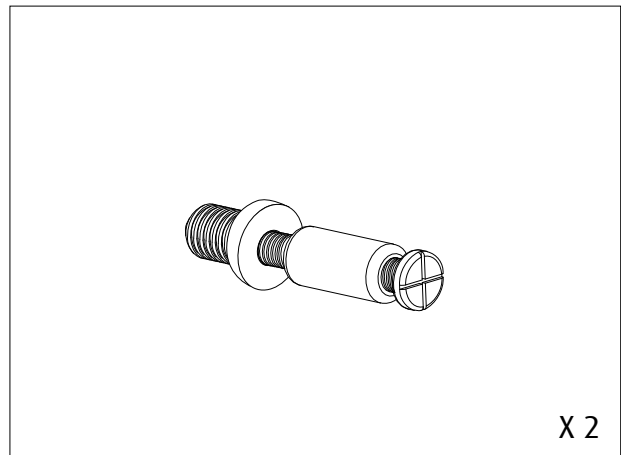
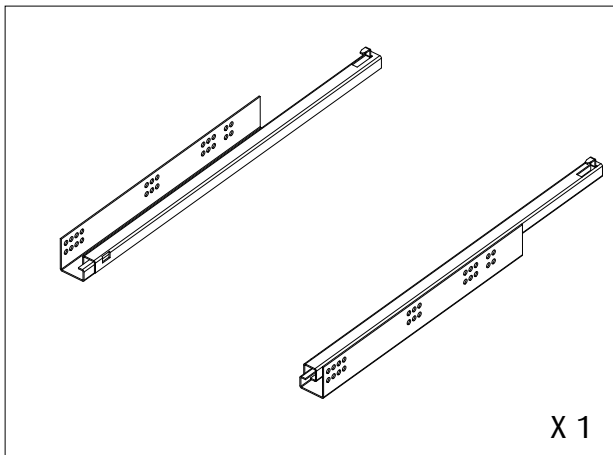
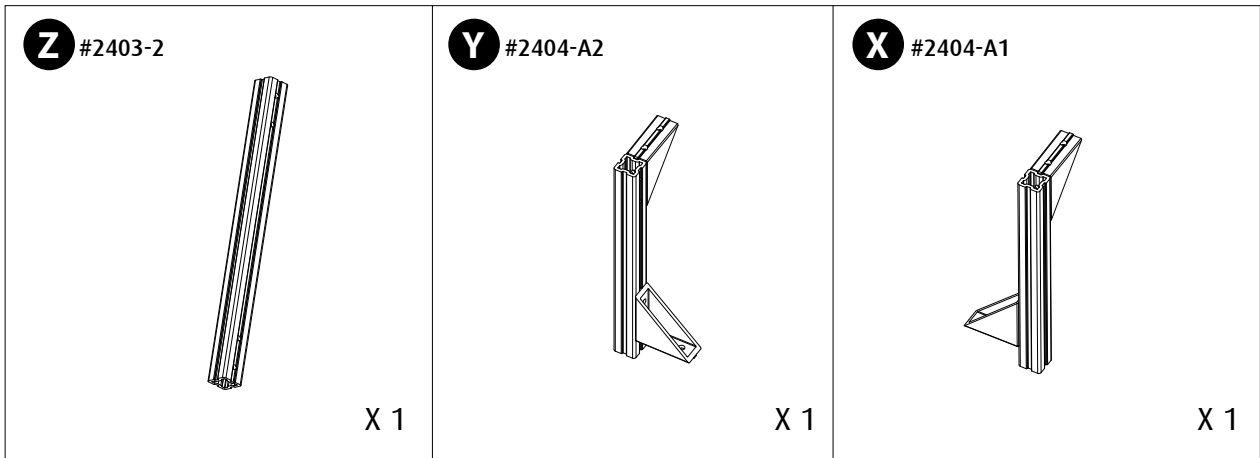

1.

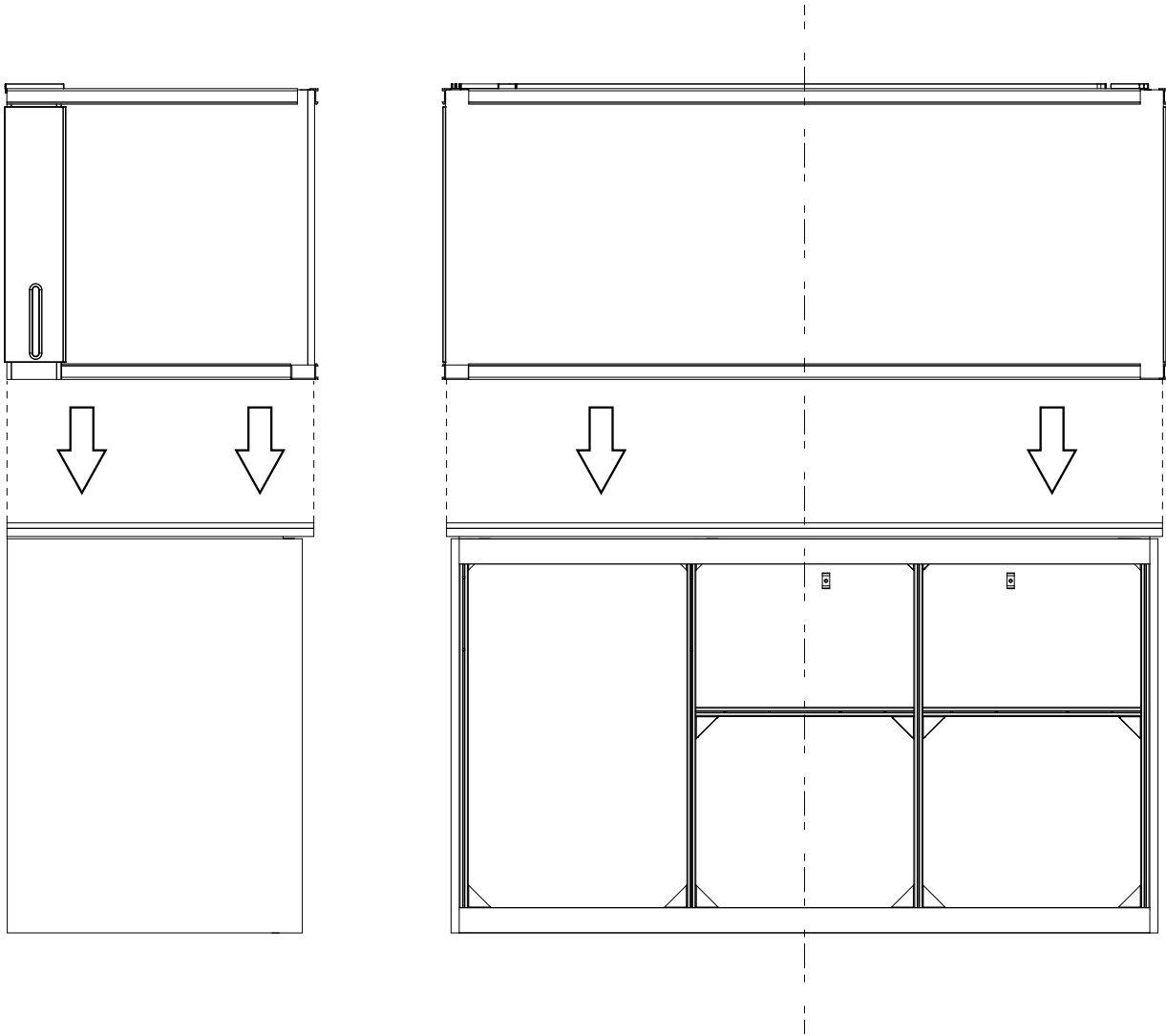

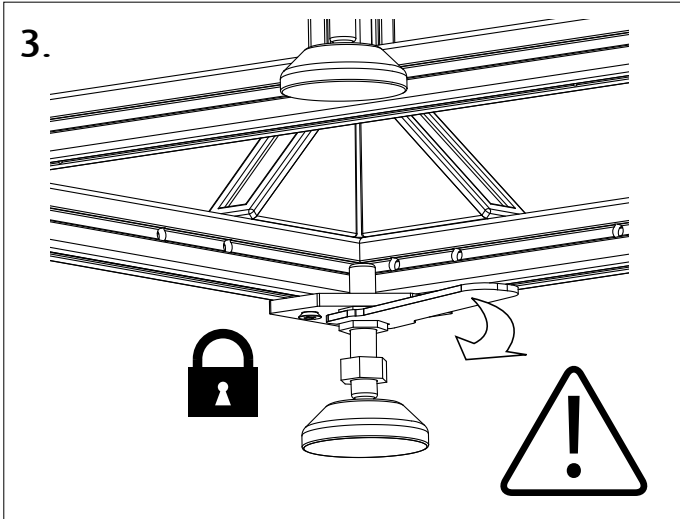
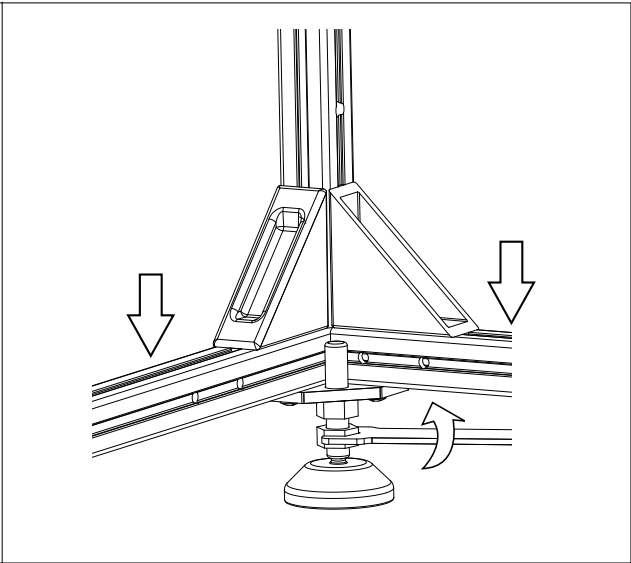
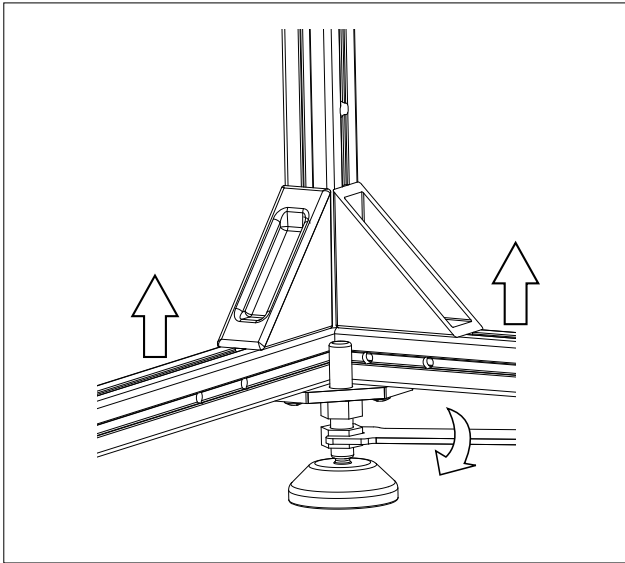
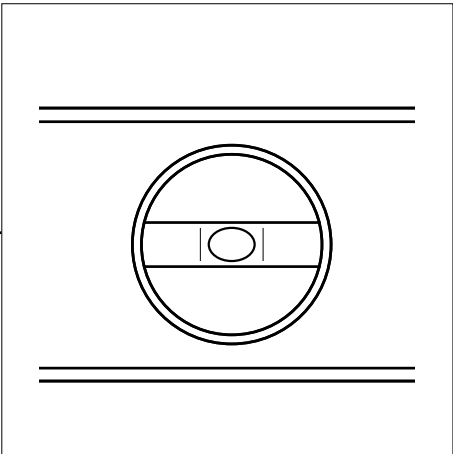
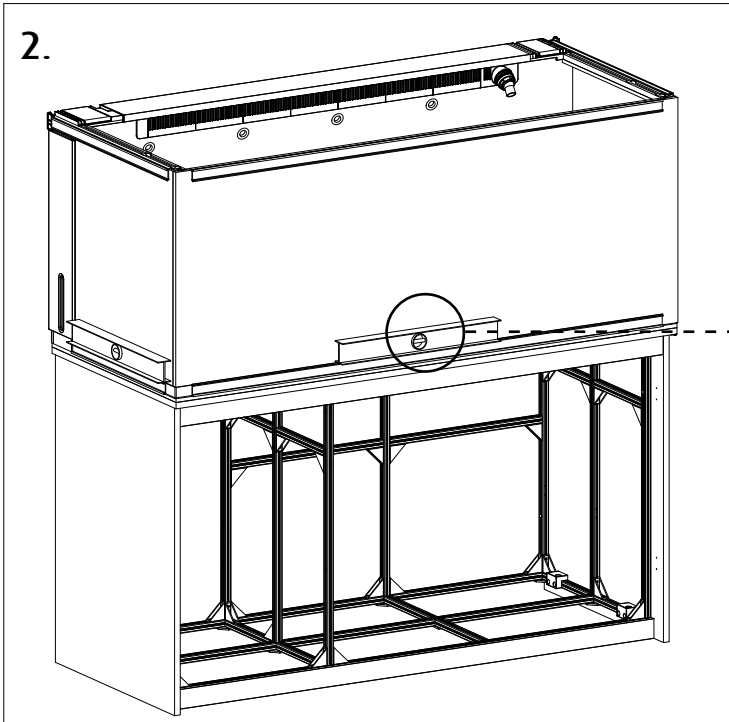

4.

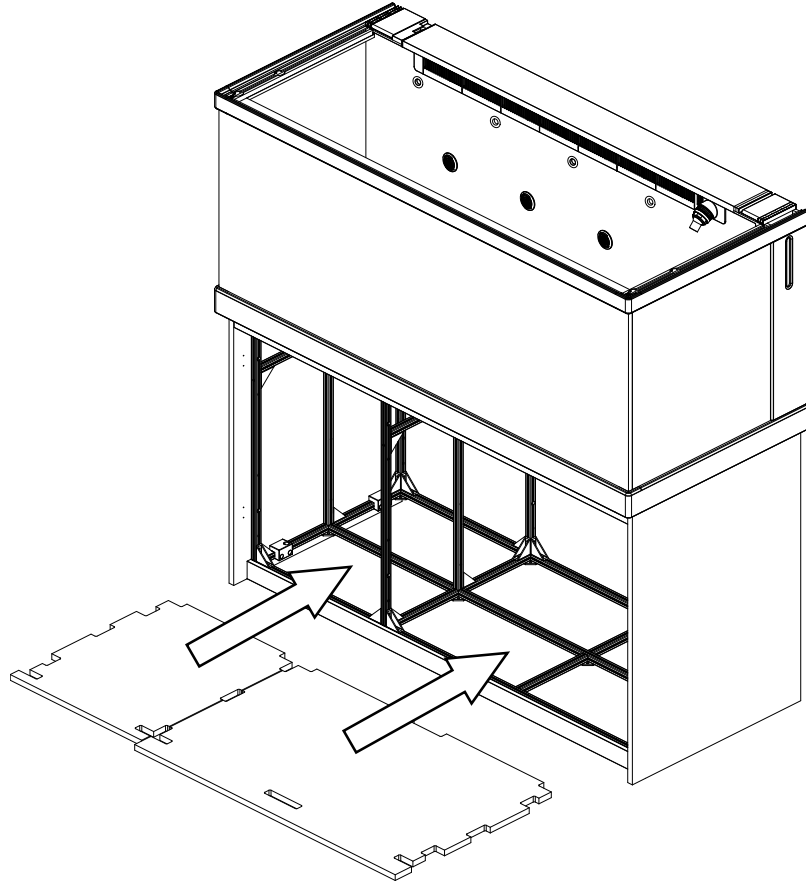

5.

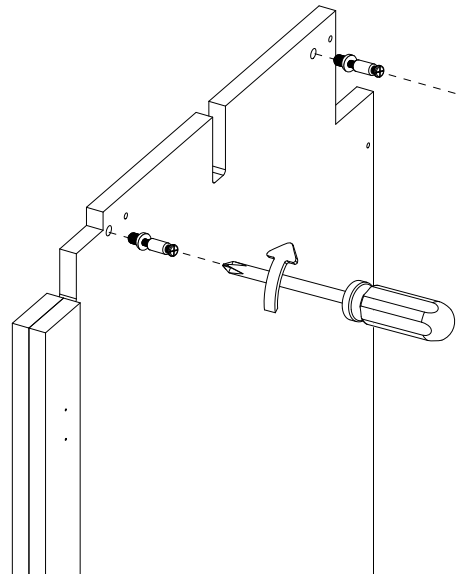
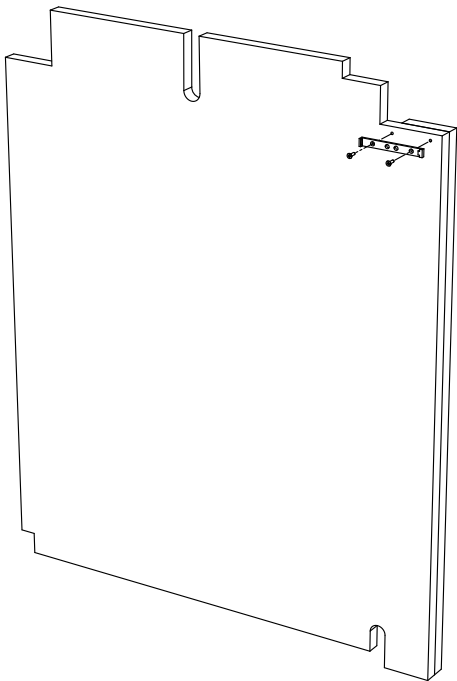

X 2

6.

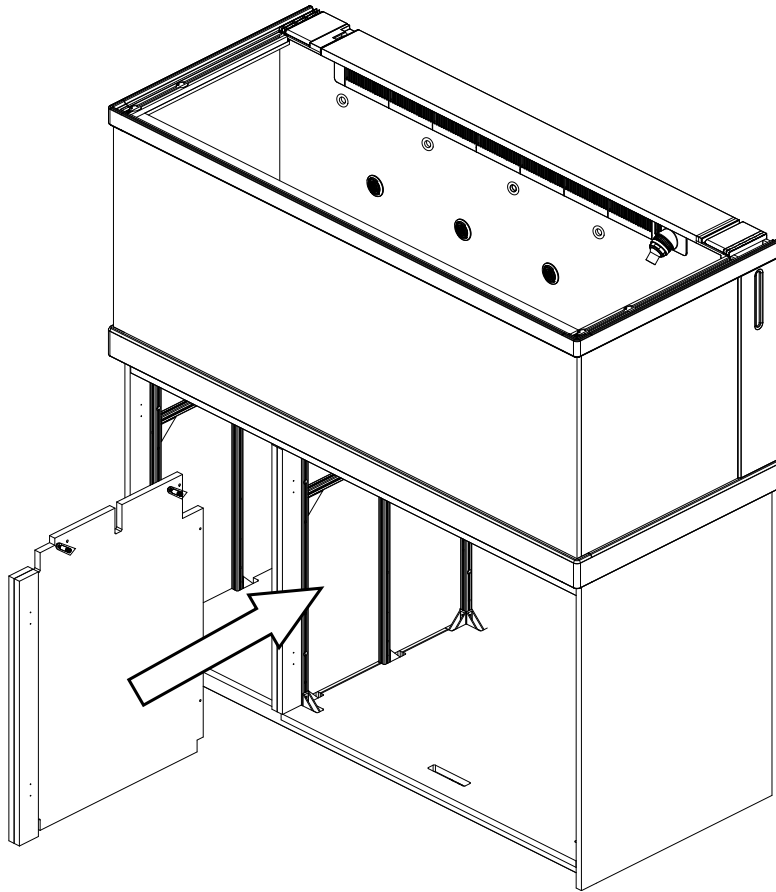

7.

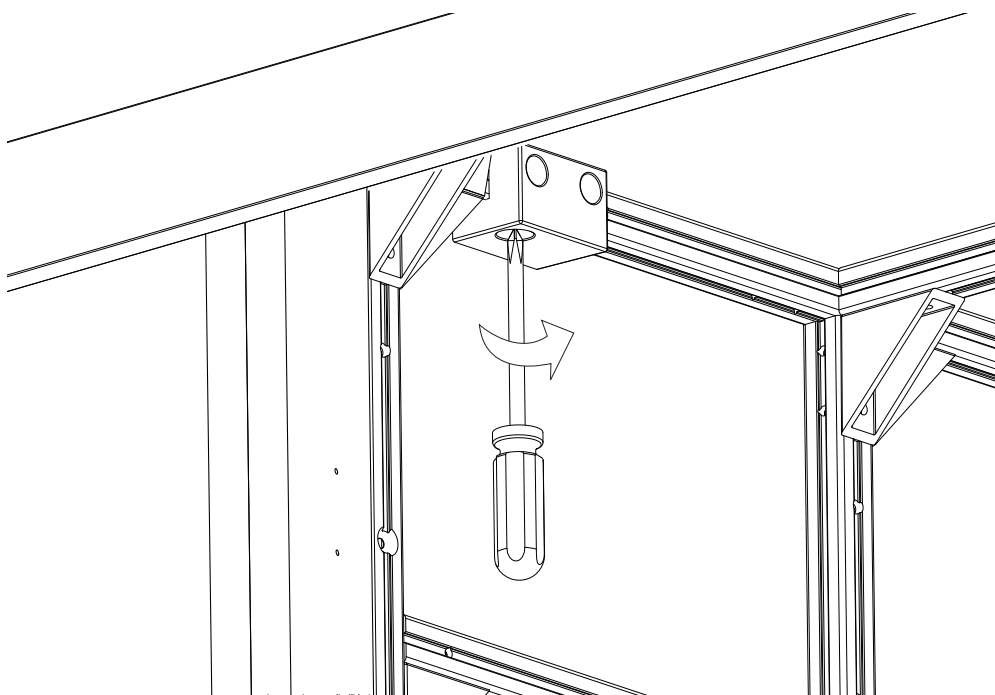

8.

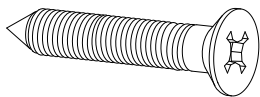
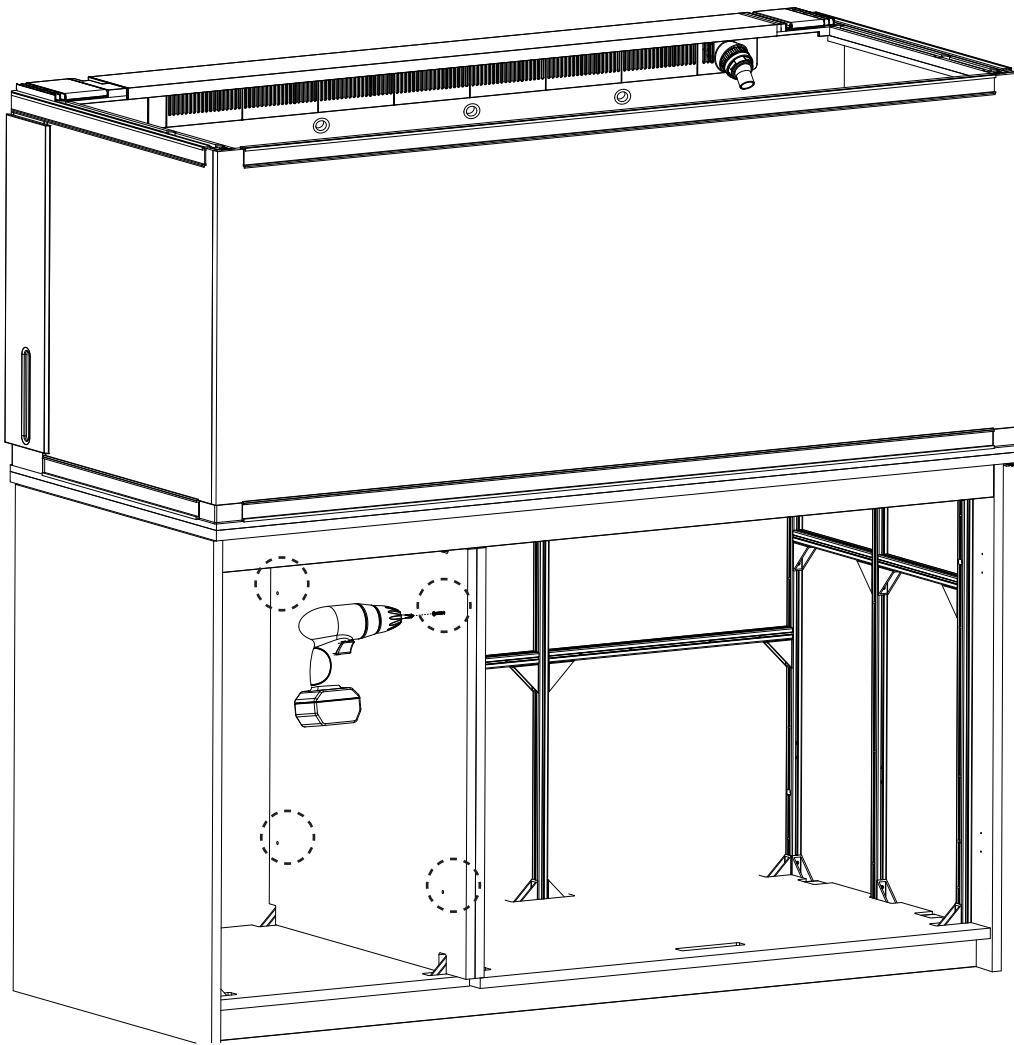

S7 X 4

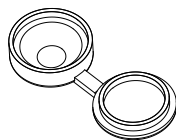

X 4

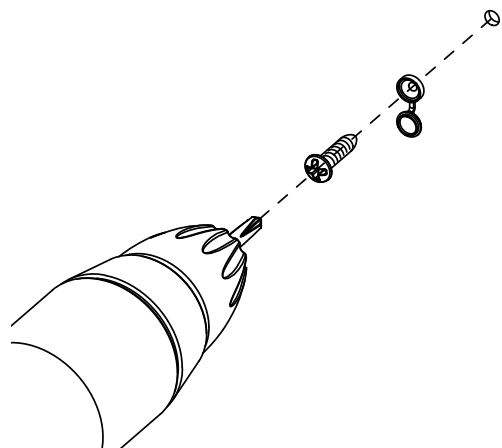

9.

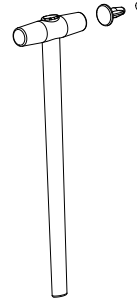
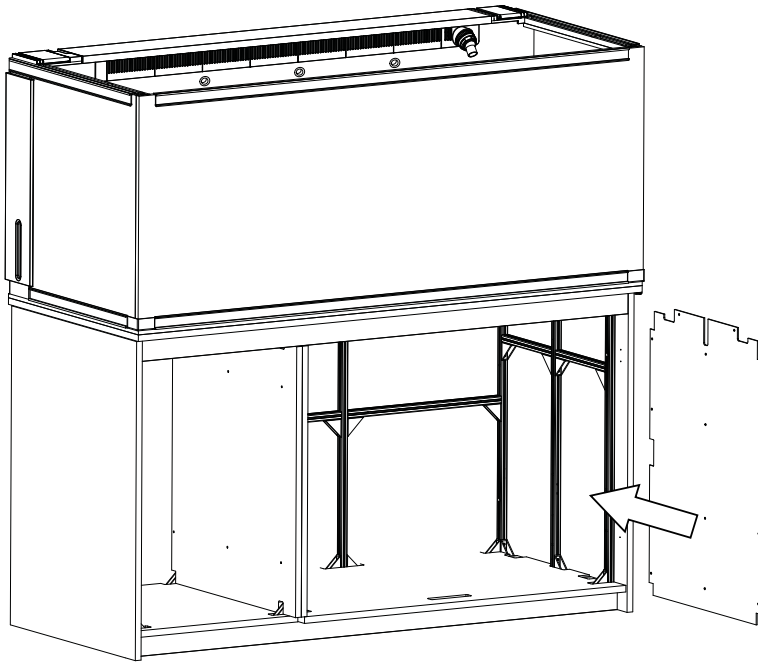

X 14

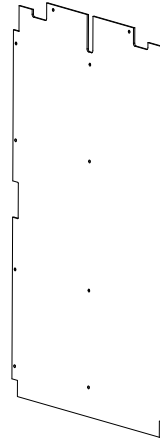

10.

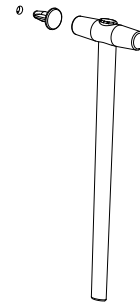
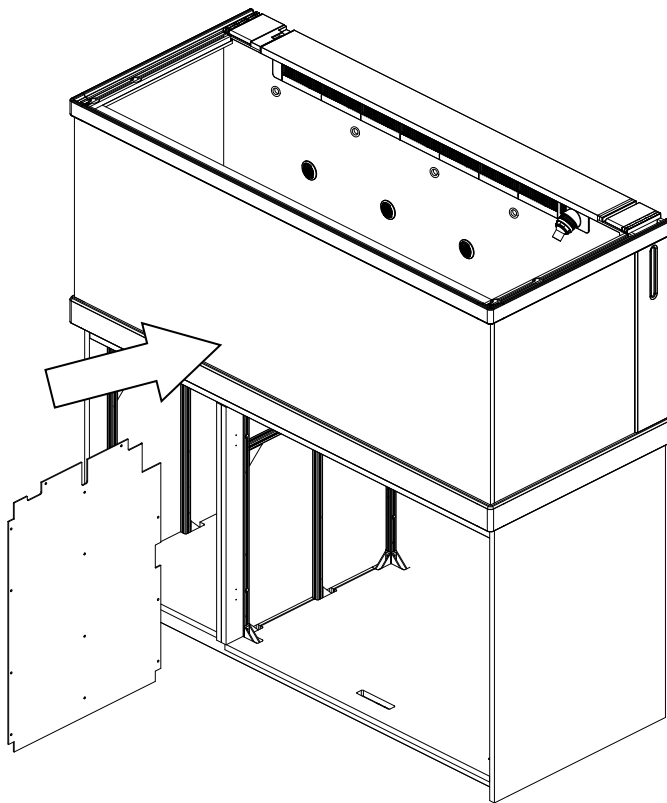

X 13

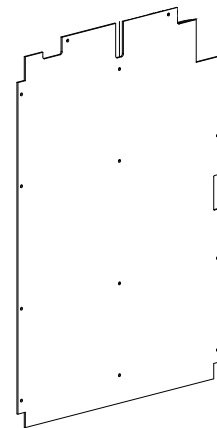

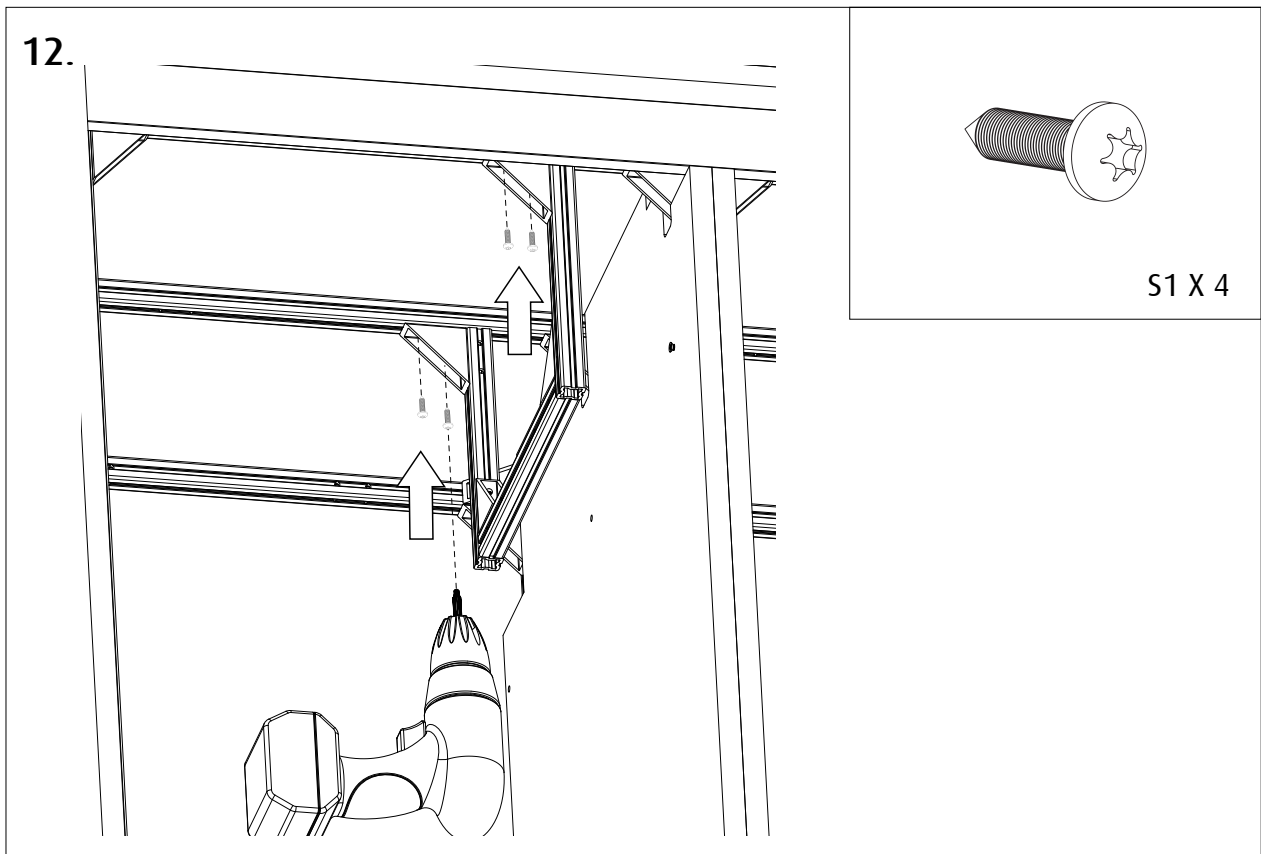
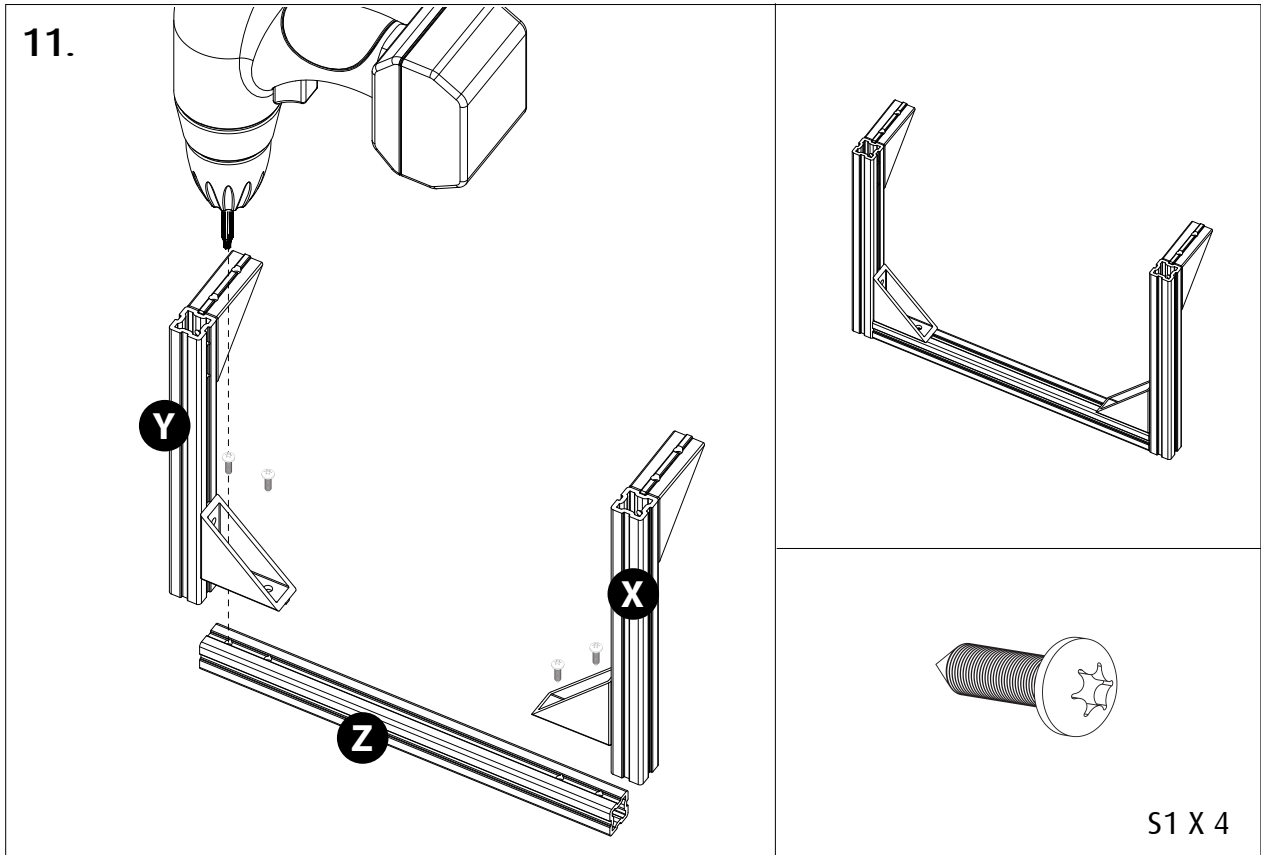

13.

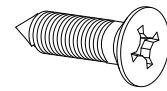
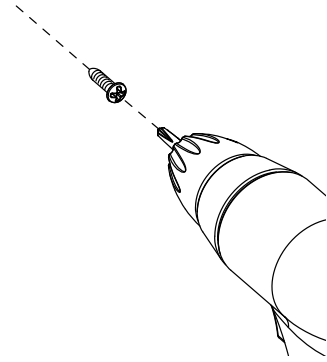
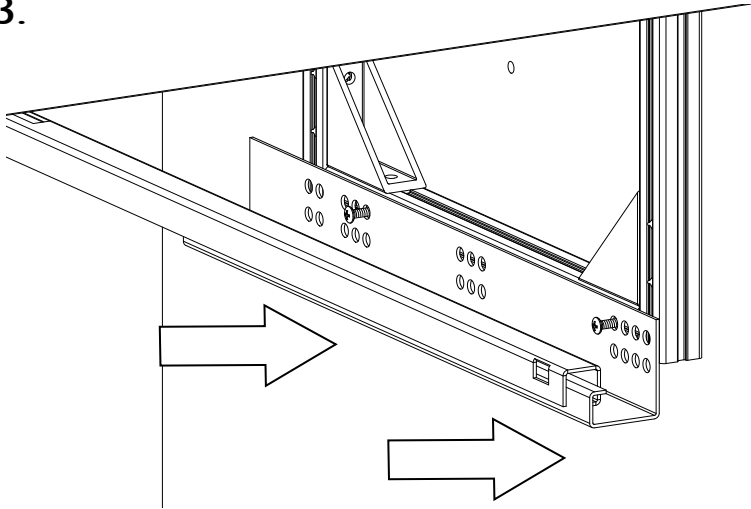

S2 X 2

14.a

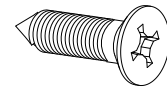
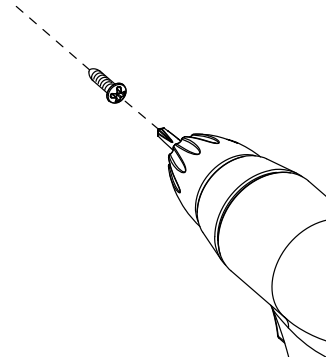
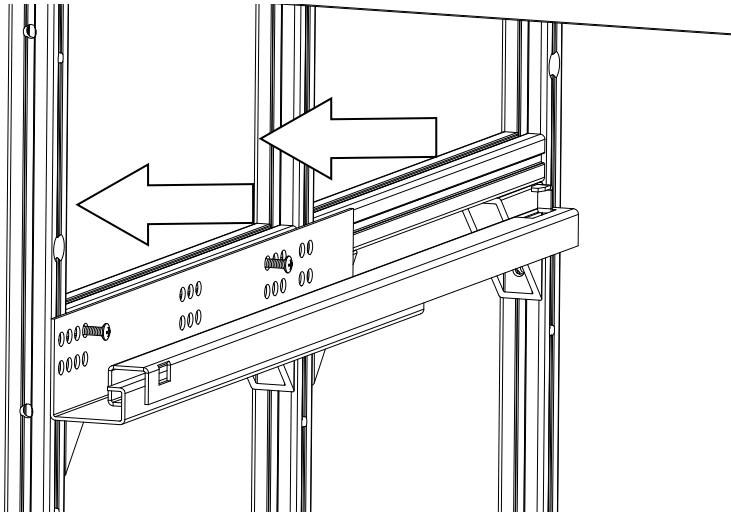

S2 X 2

14.b

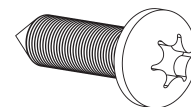
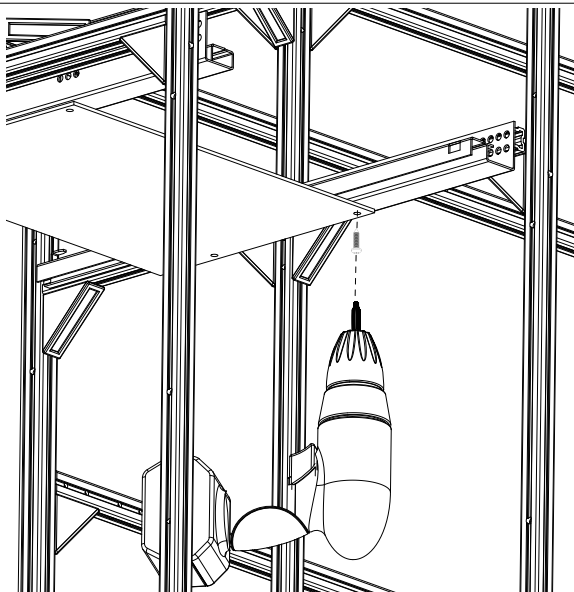

S1 X 4

15.

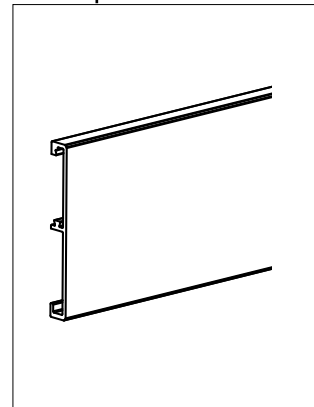
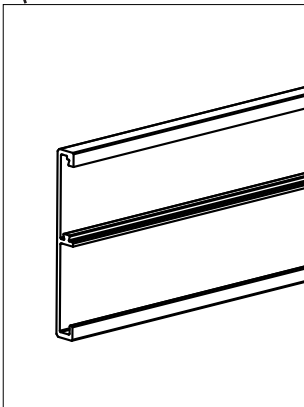
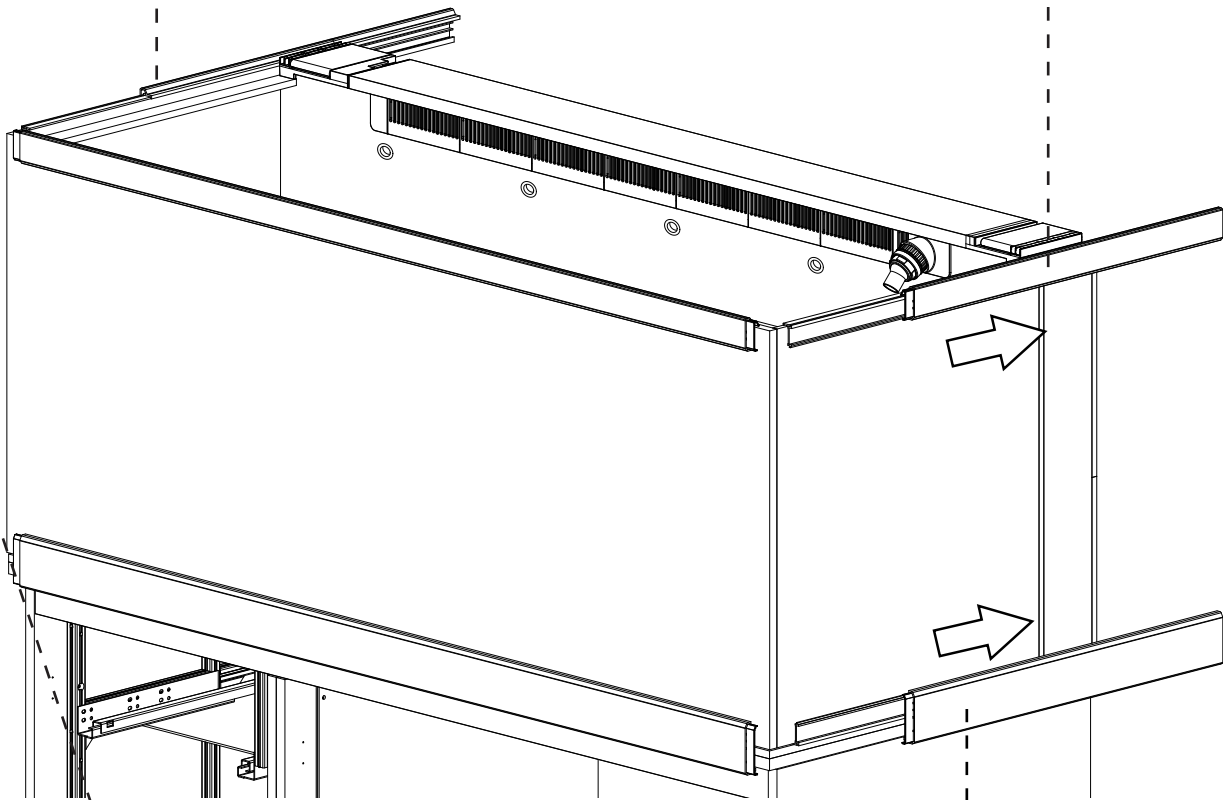
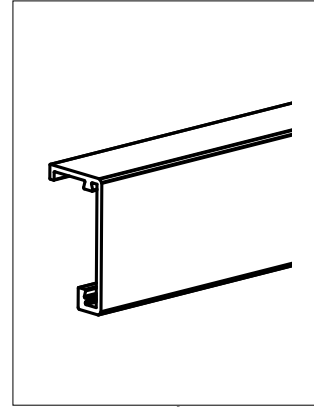
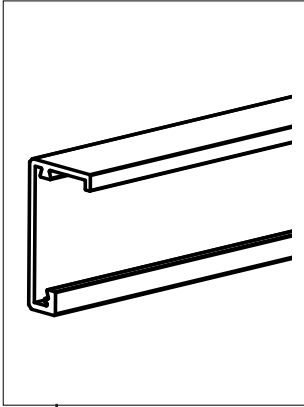

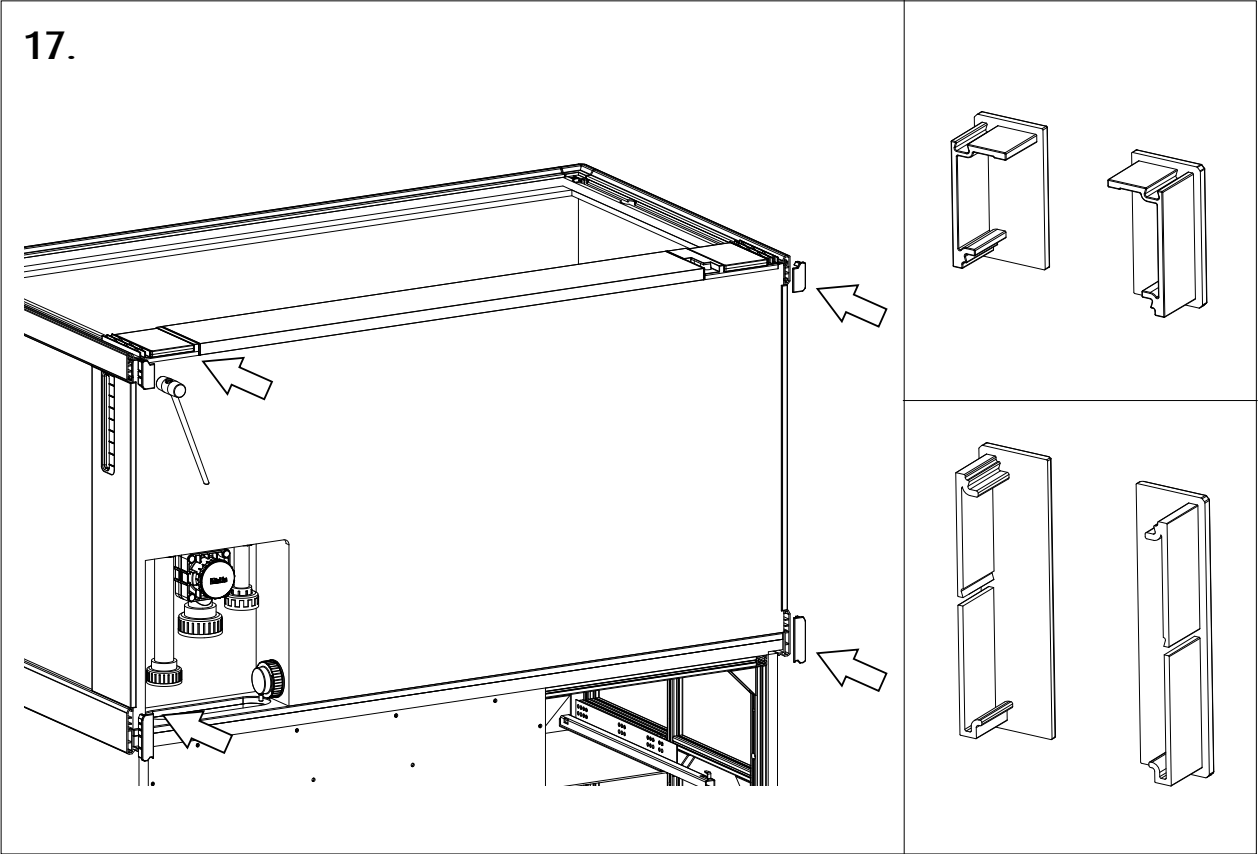
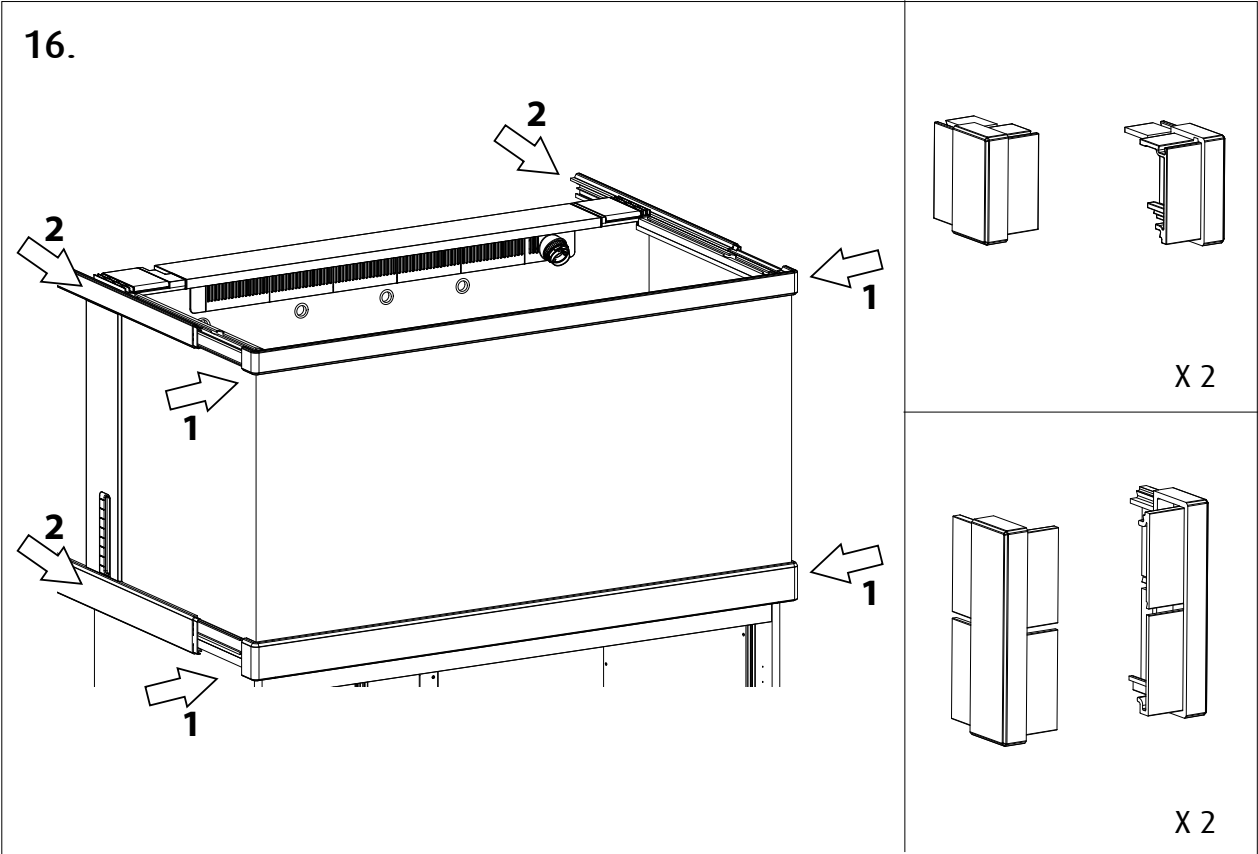

18.

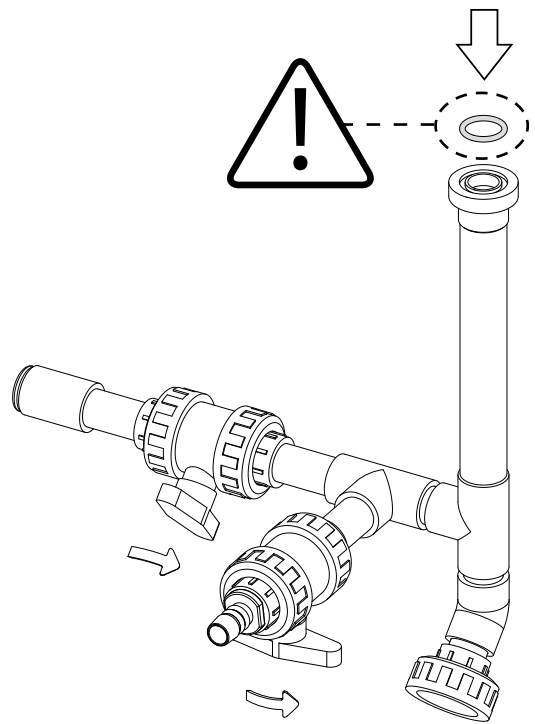
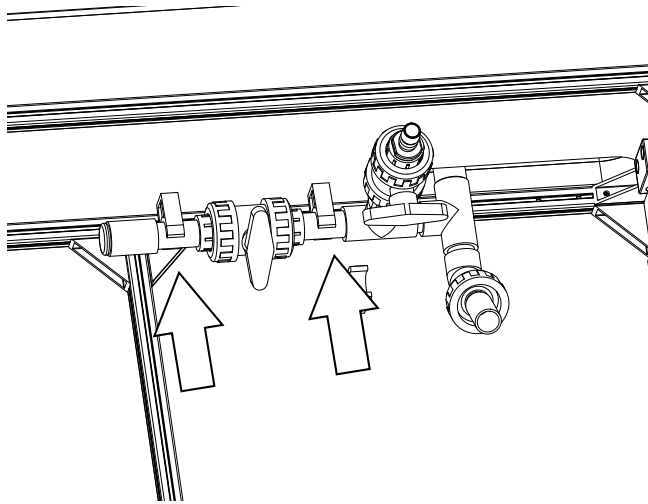

19.

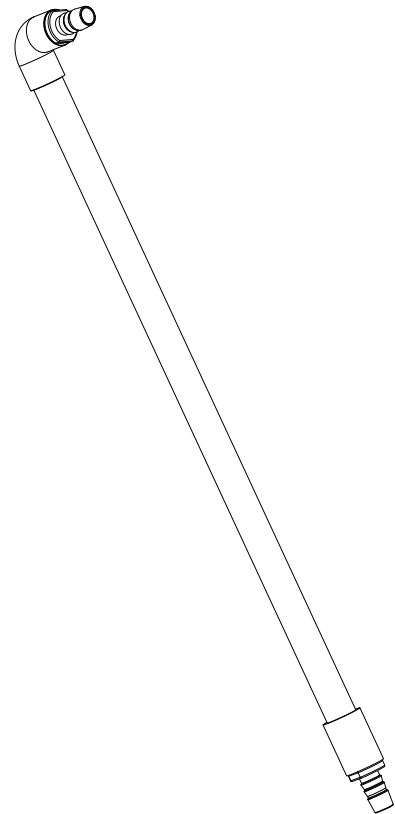
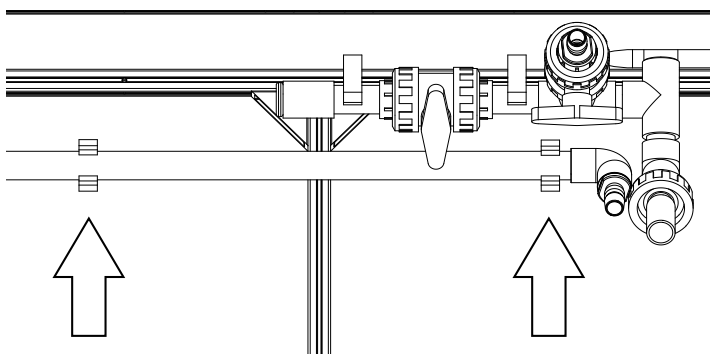

20.

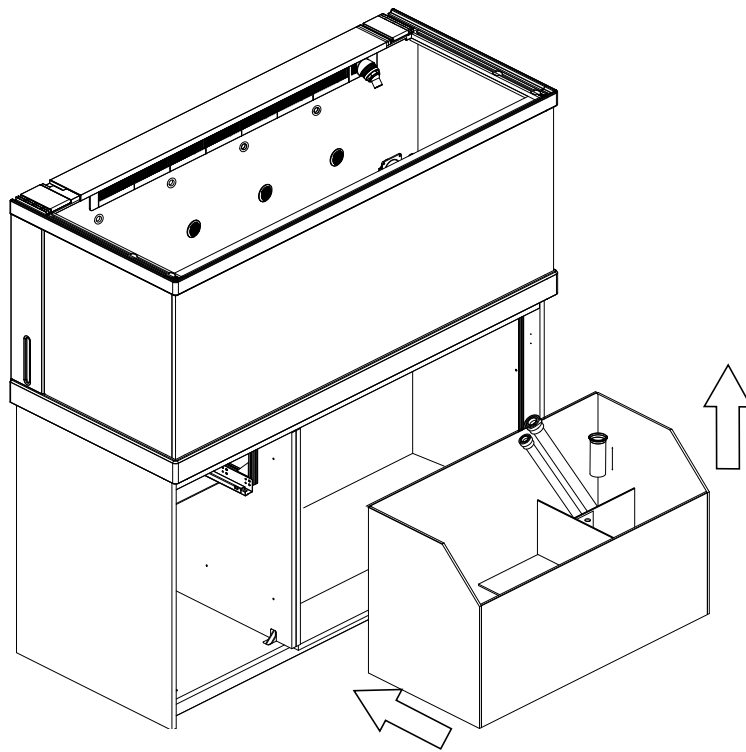

21.

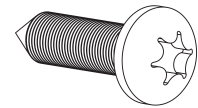
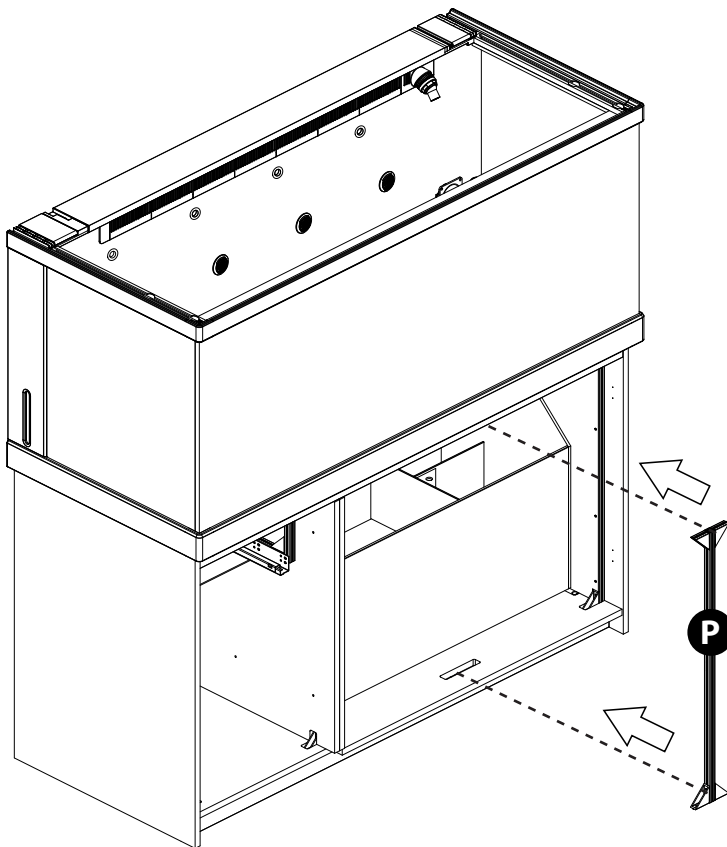

S1 X 8

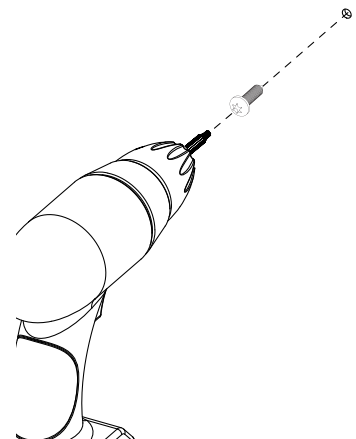

22.

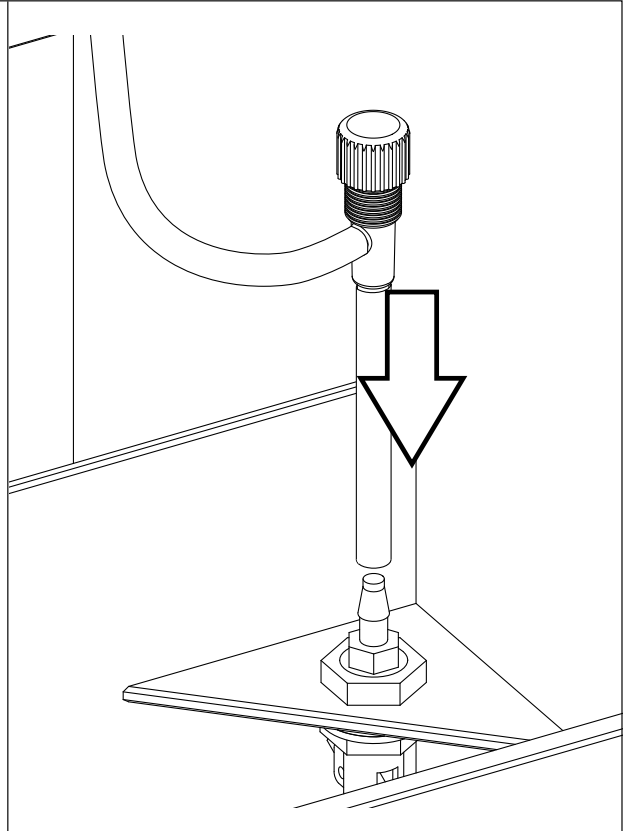
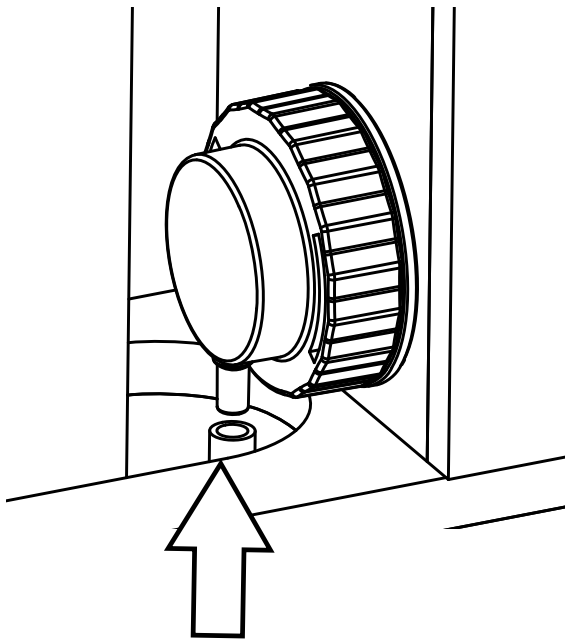

23.

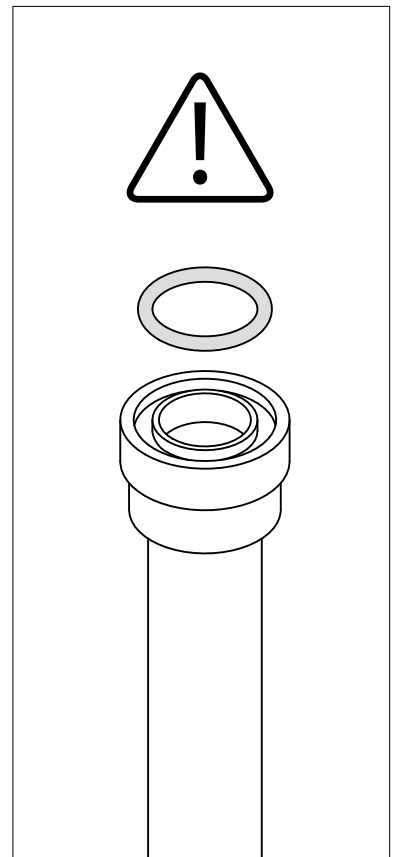
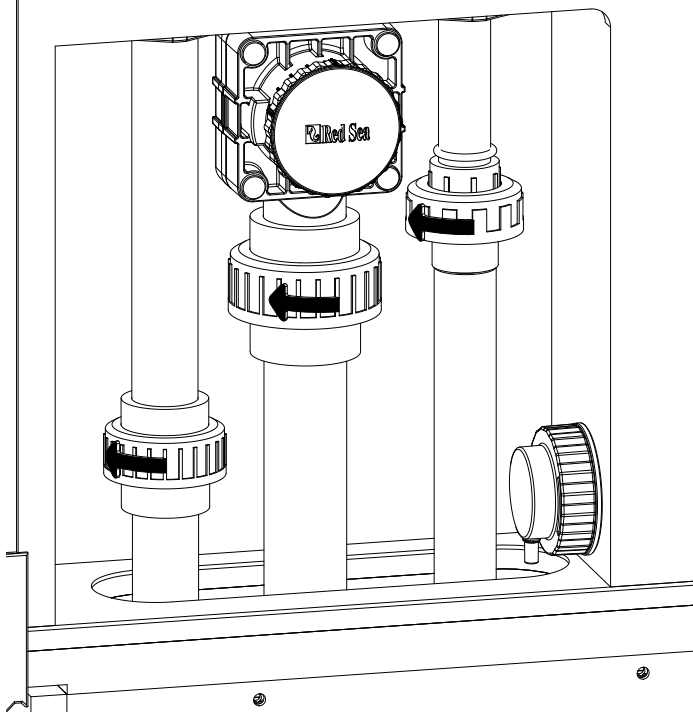

24.

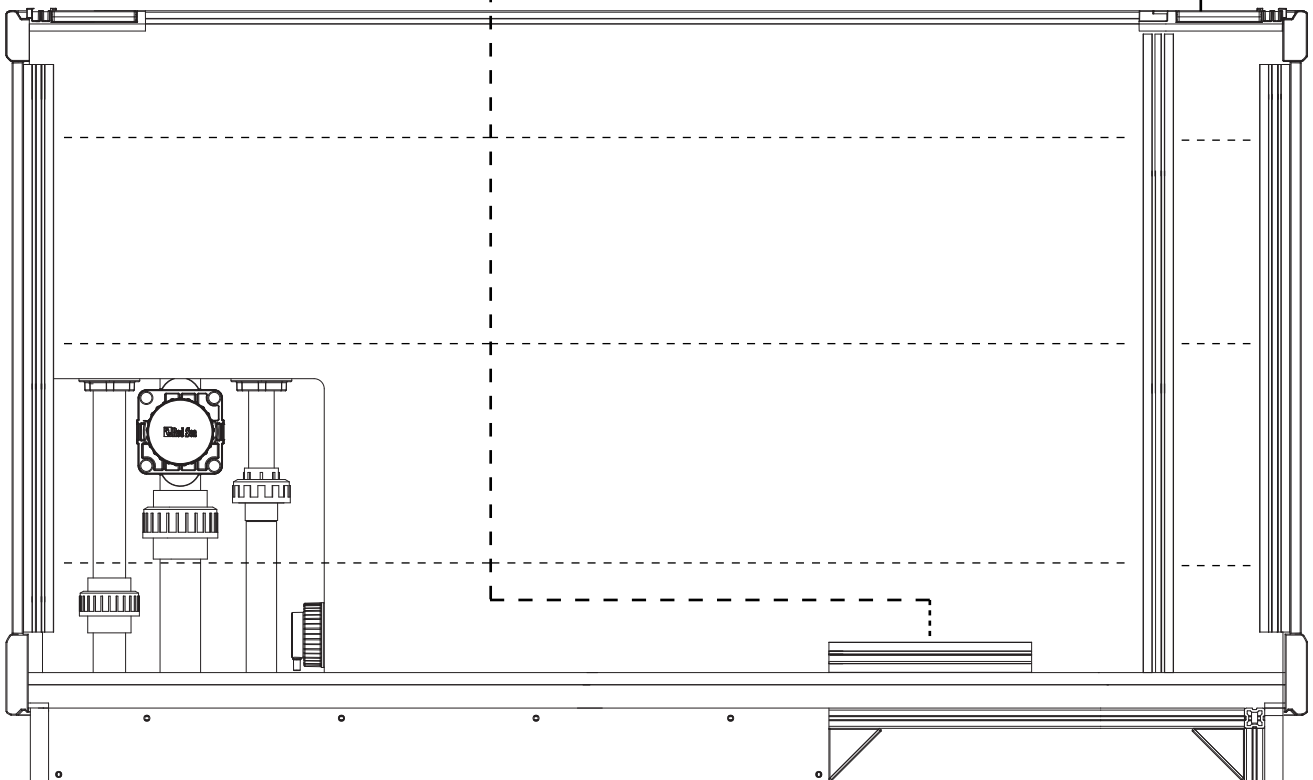
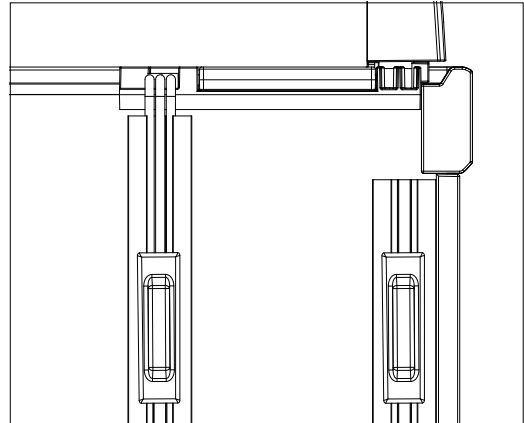
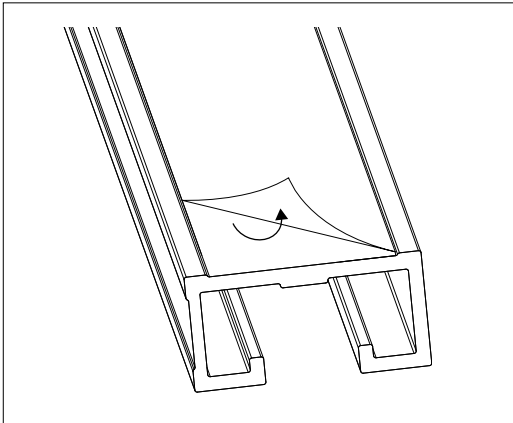

25.

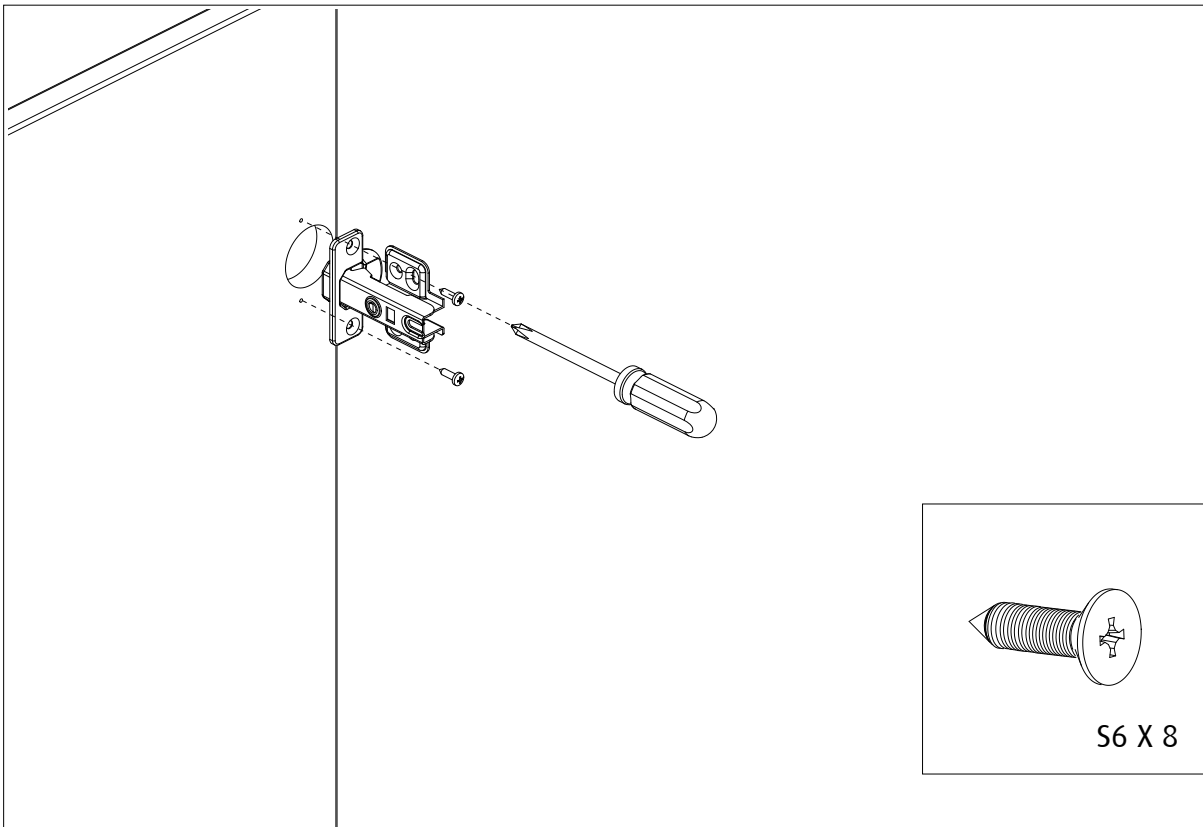
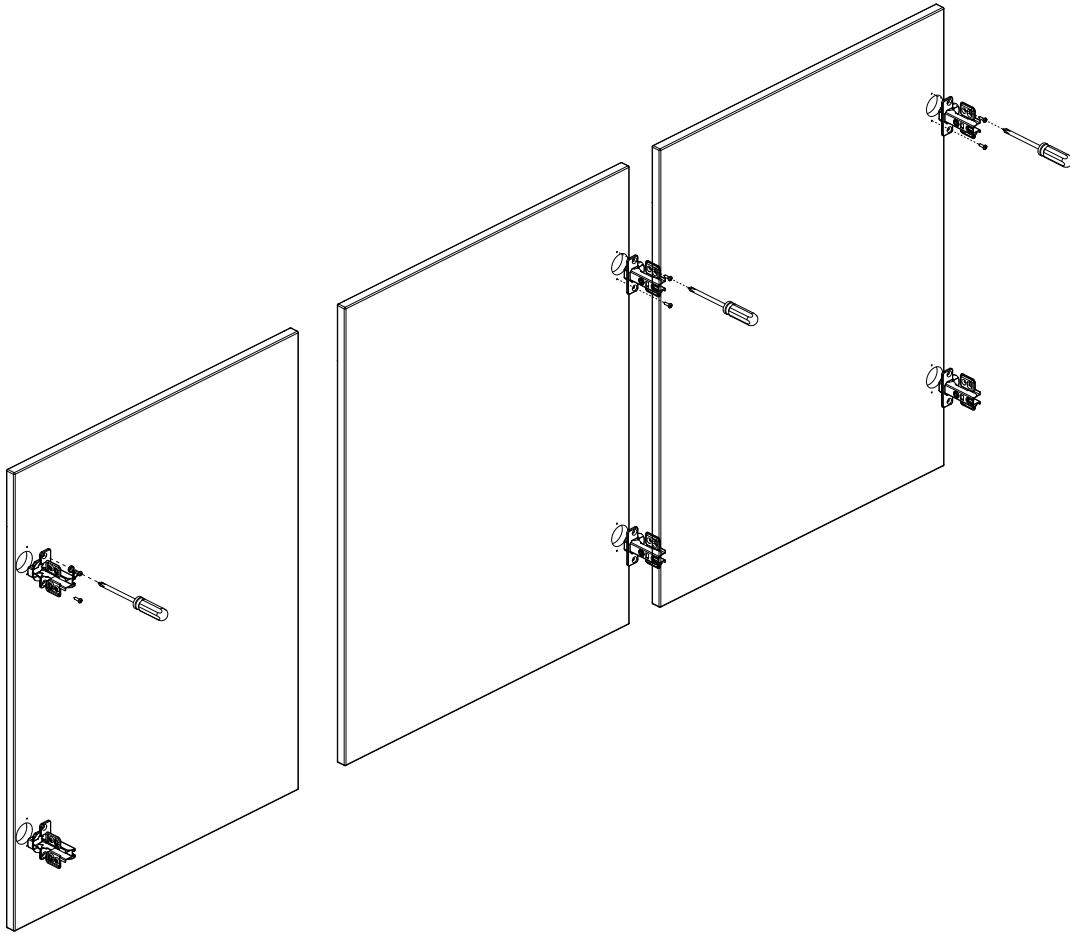

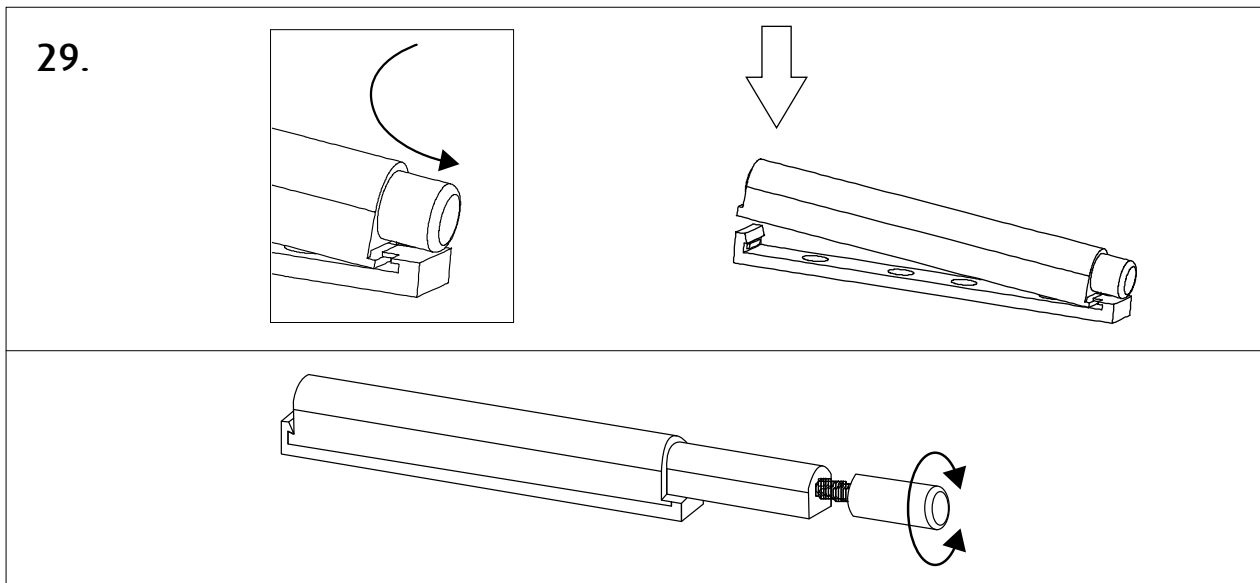
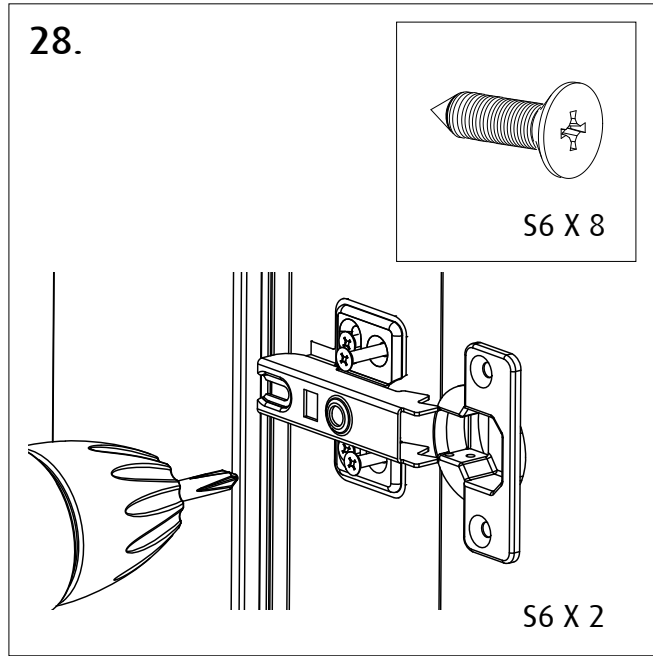
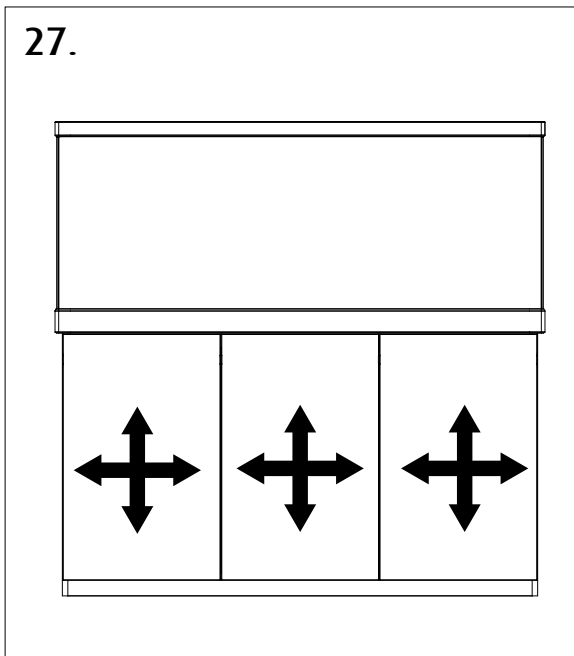
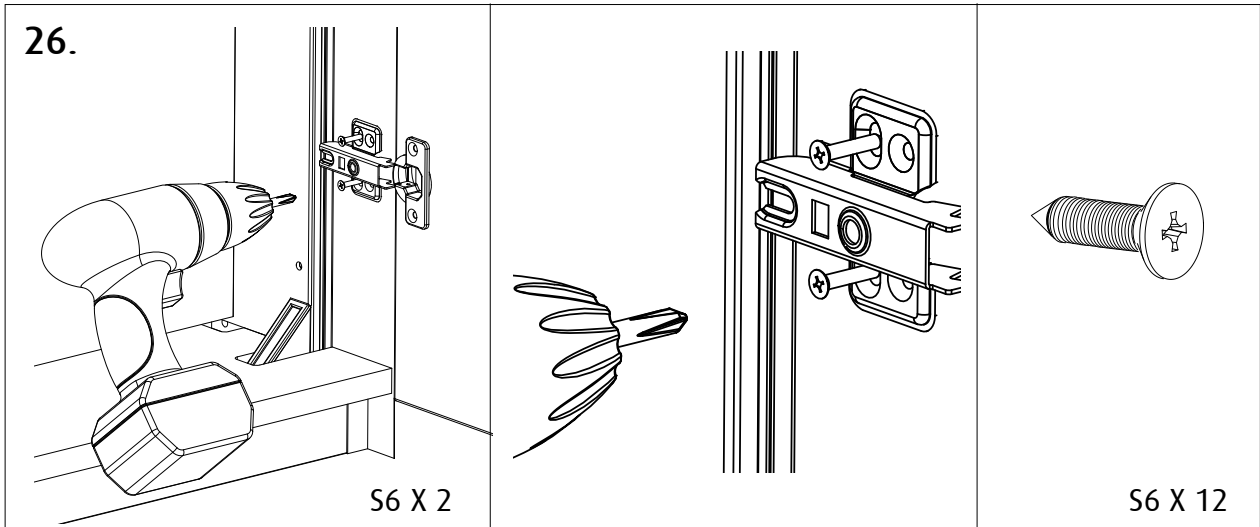

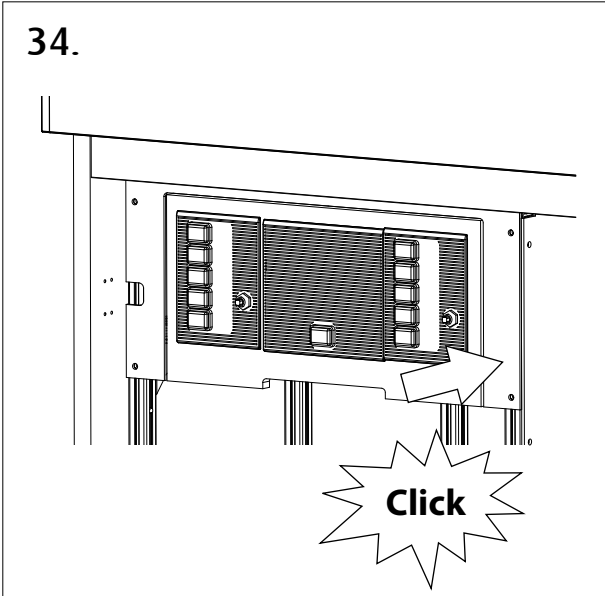
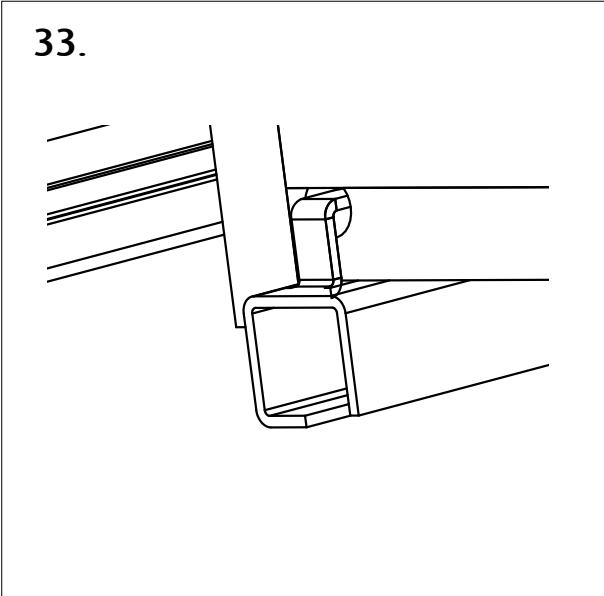
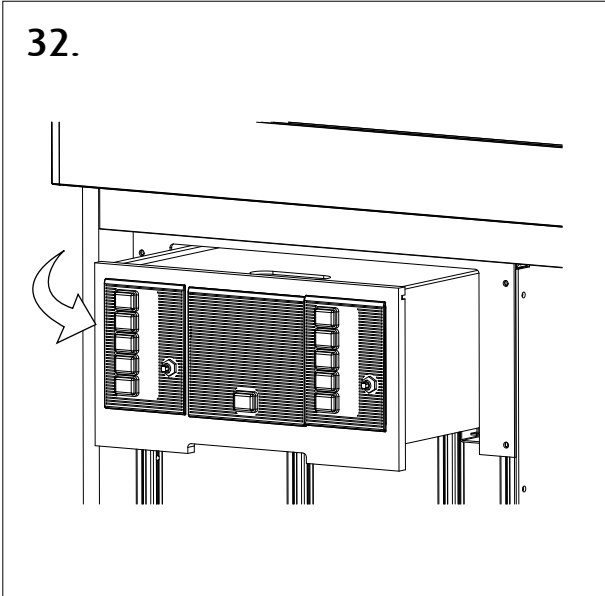
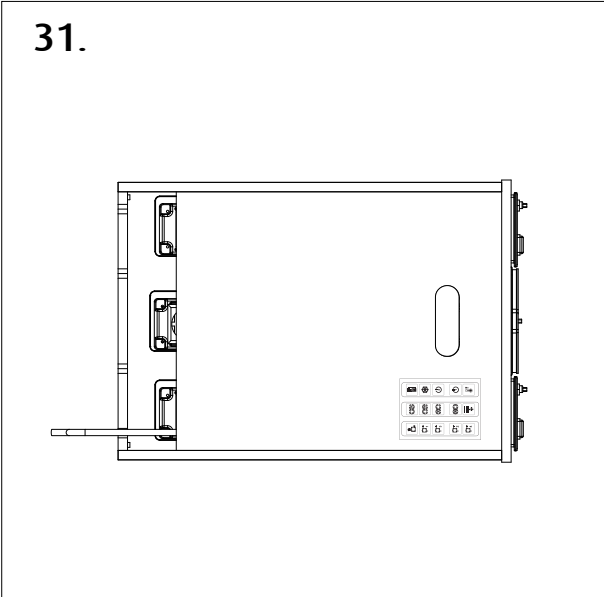
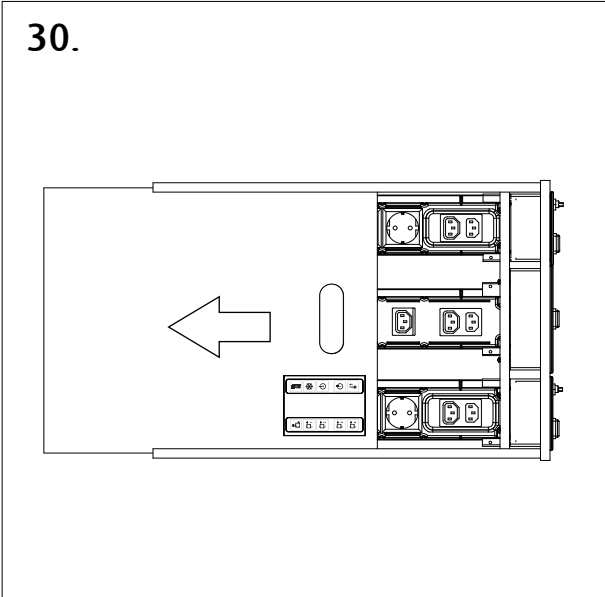

#5

Pumps & Skimmer | Pumpen & Abschäumer

Pompes et écumeur | 循环泵和蛋分

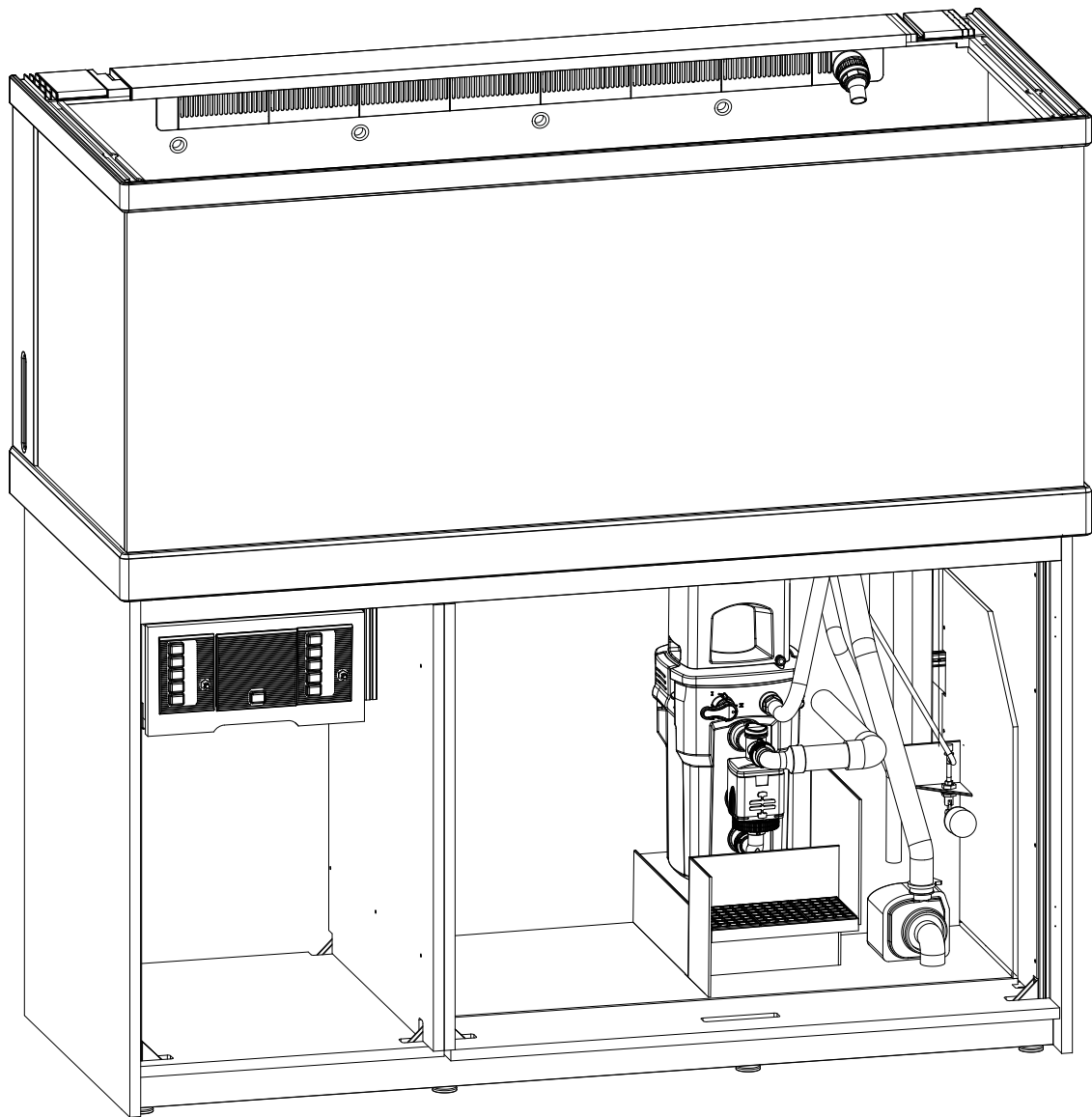

Parts | Teile | Éléments | 部件

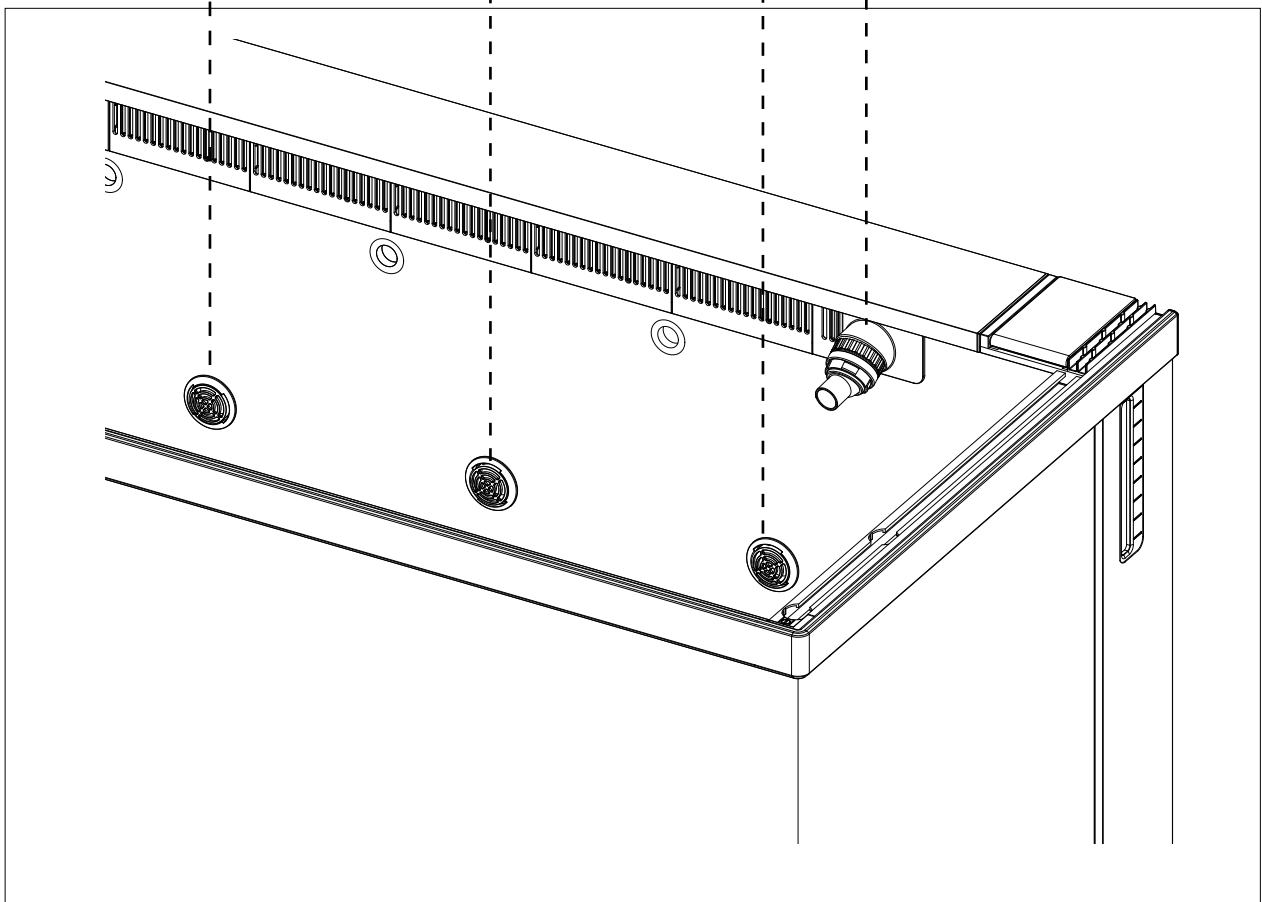
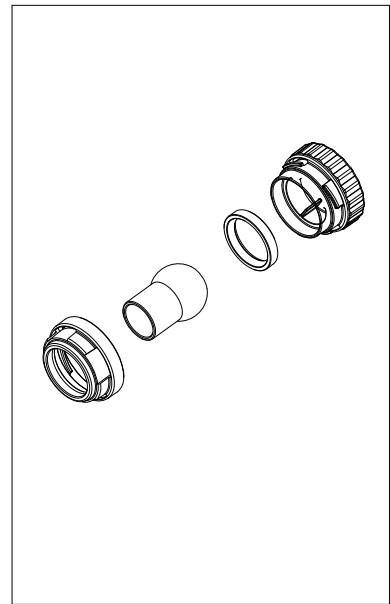
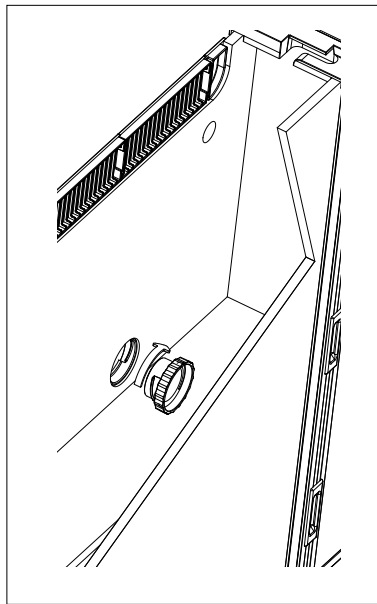
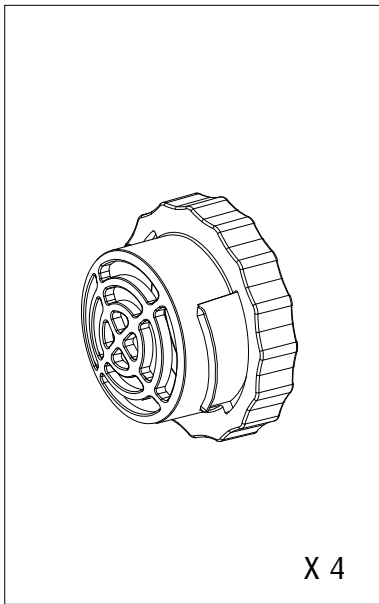

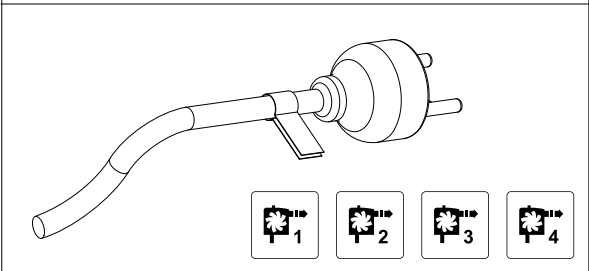
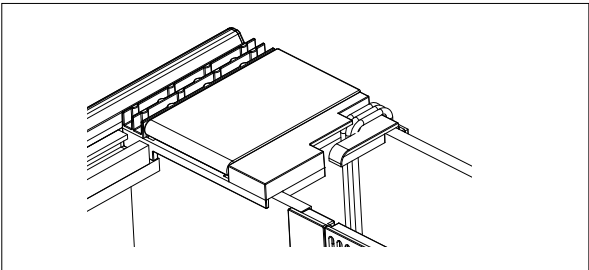
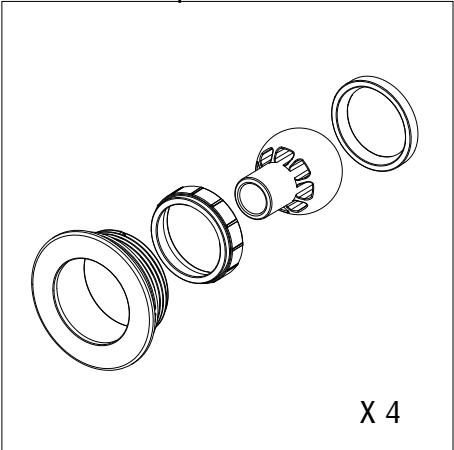
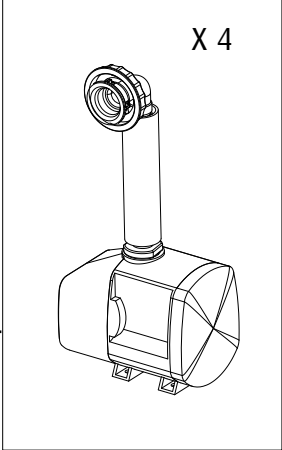
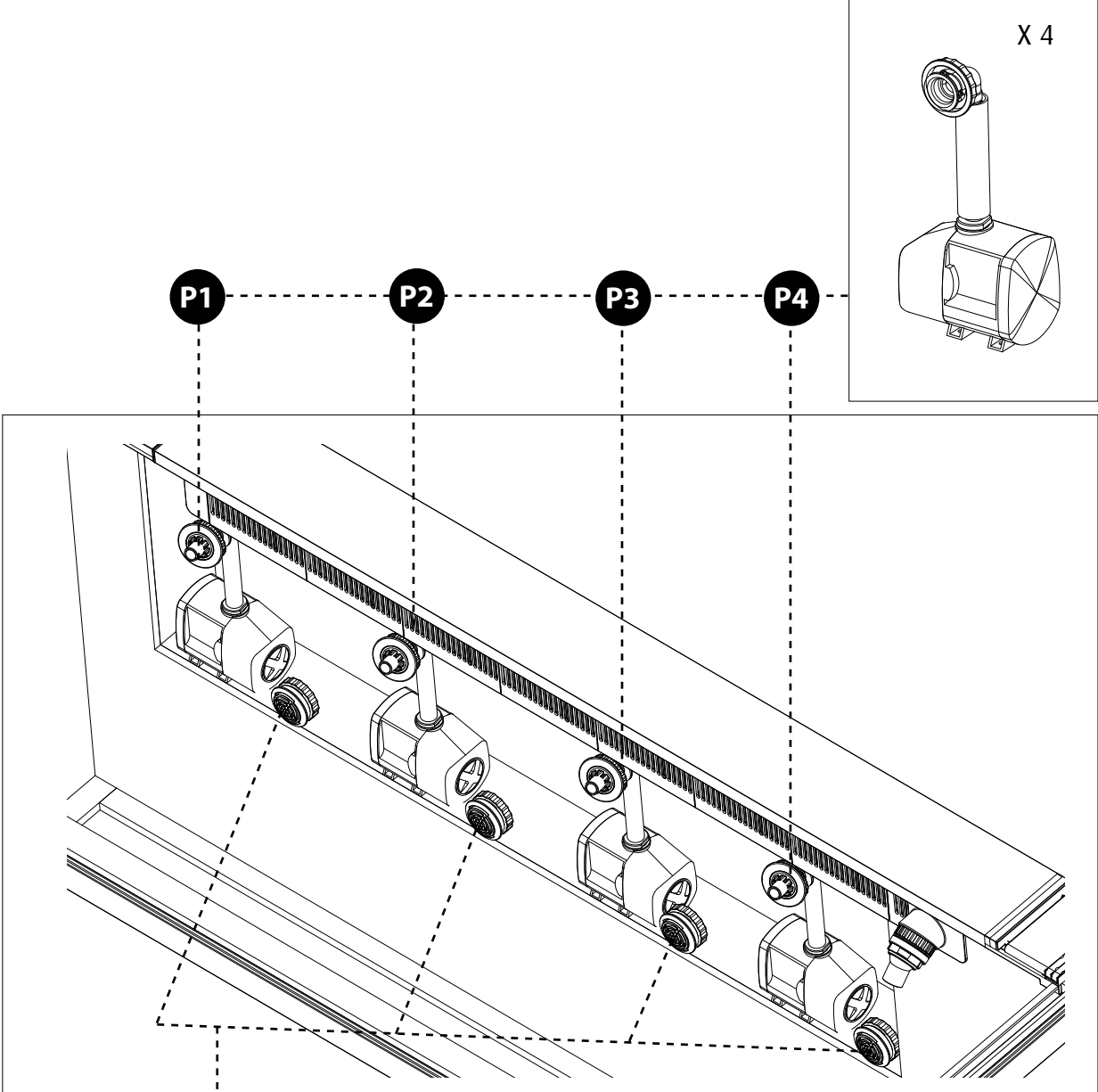

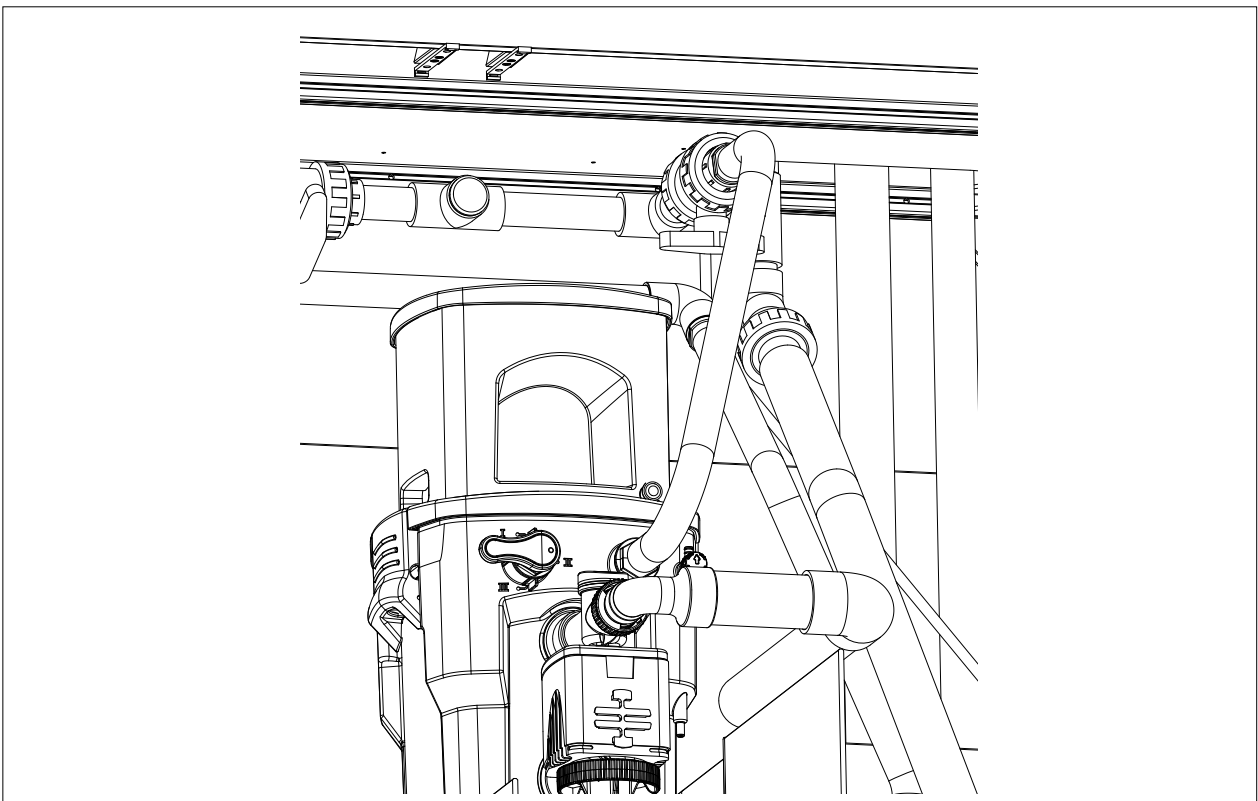
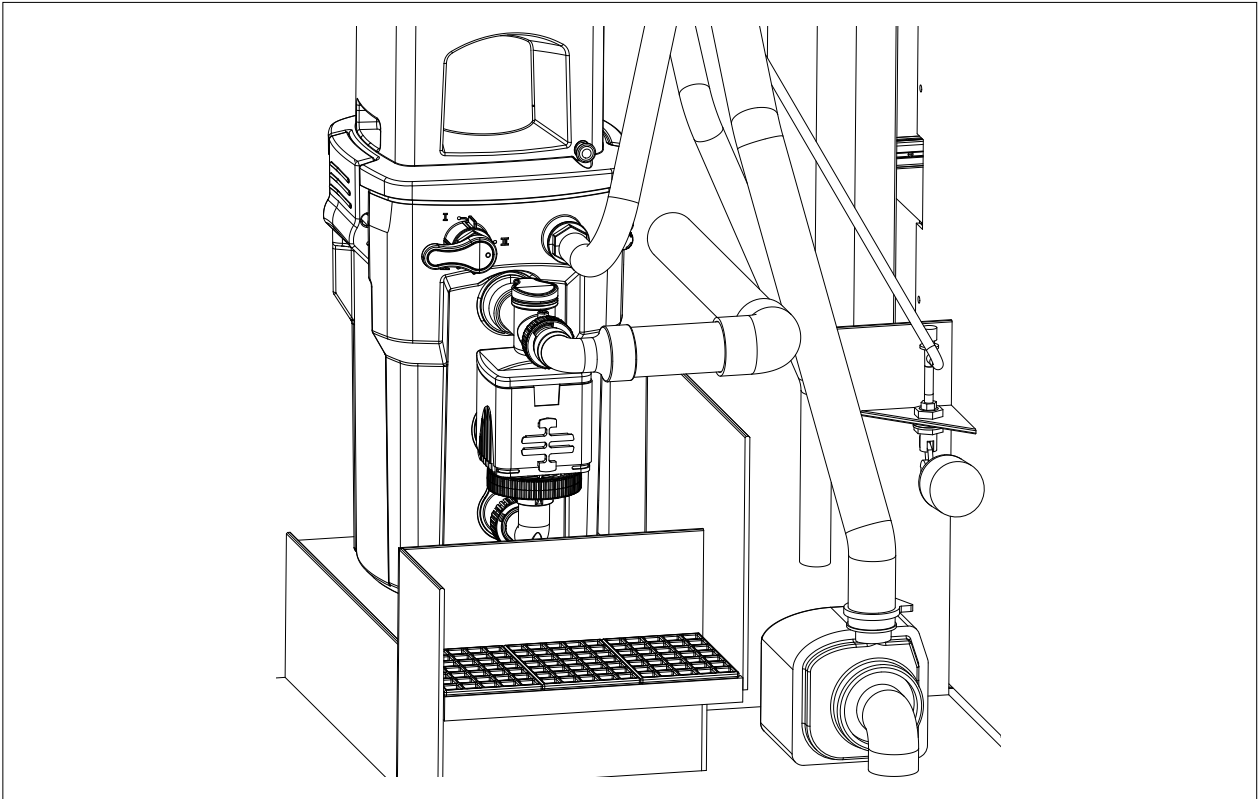

#6

Lighting & Power | Beleuchtung und Strom
Eclairage et Power Center | 照明设备和电源中心

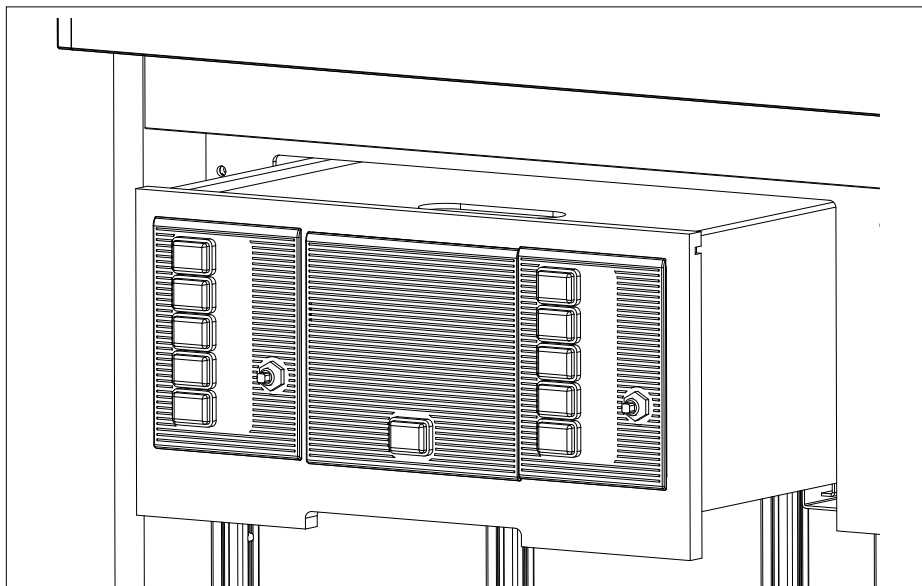
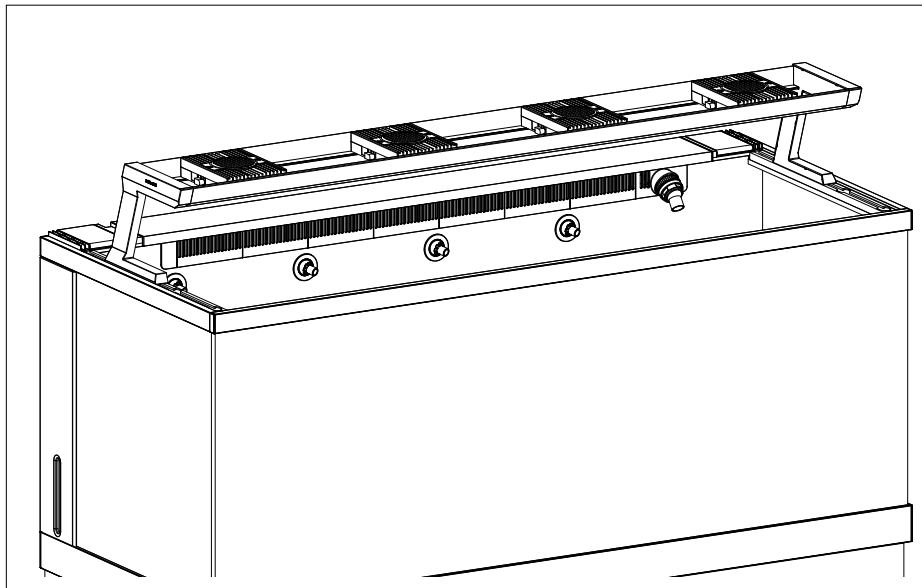

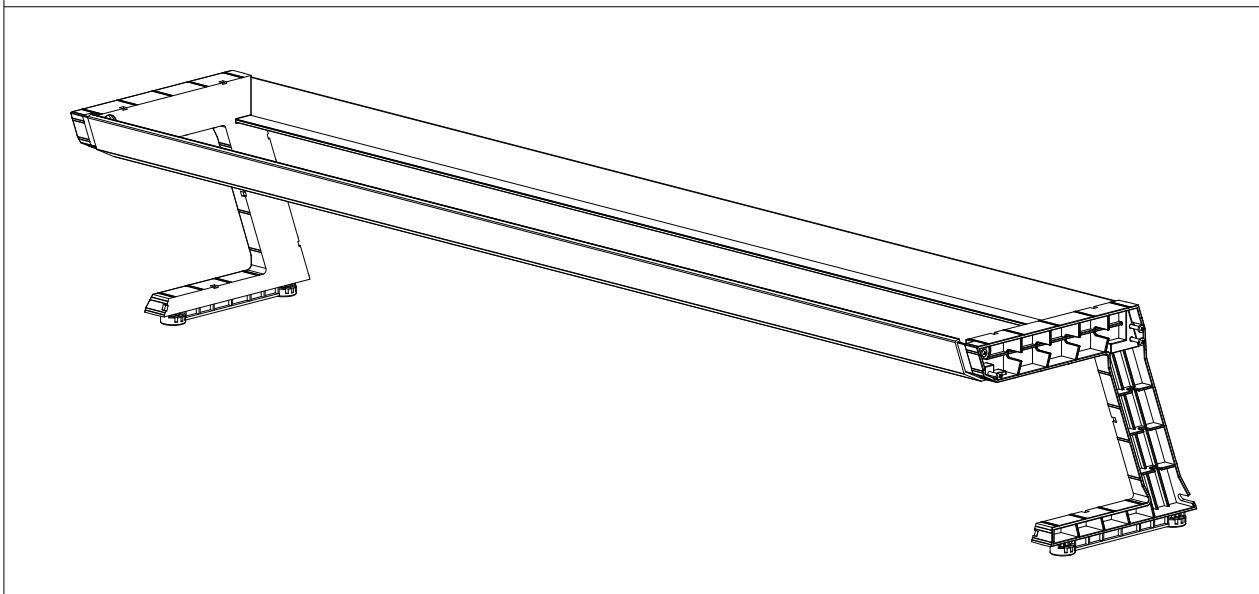
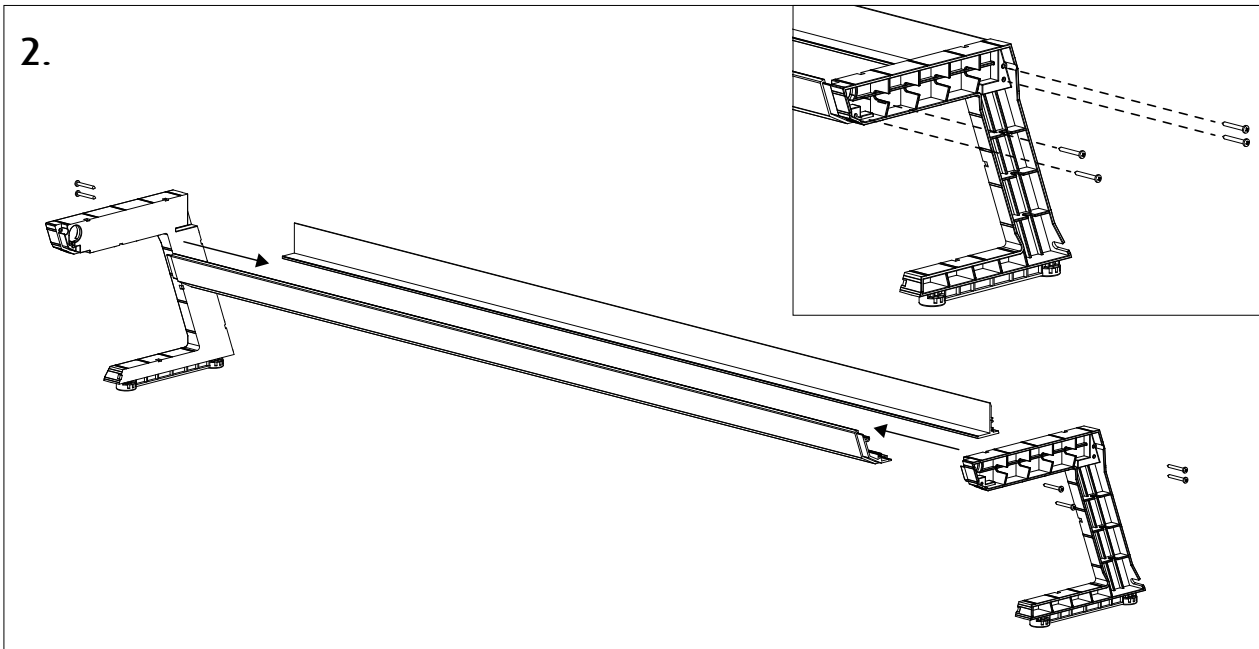
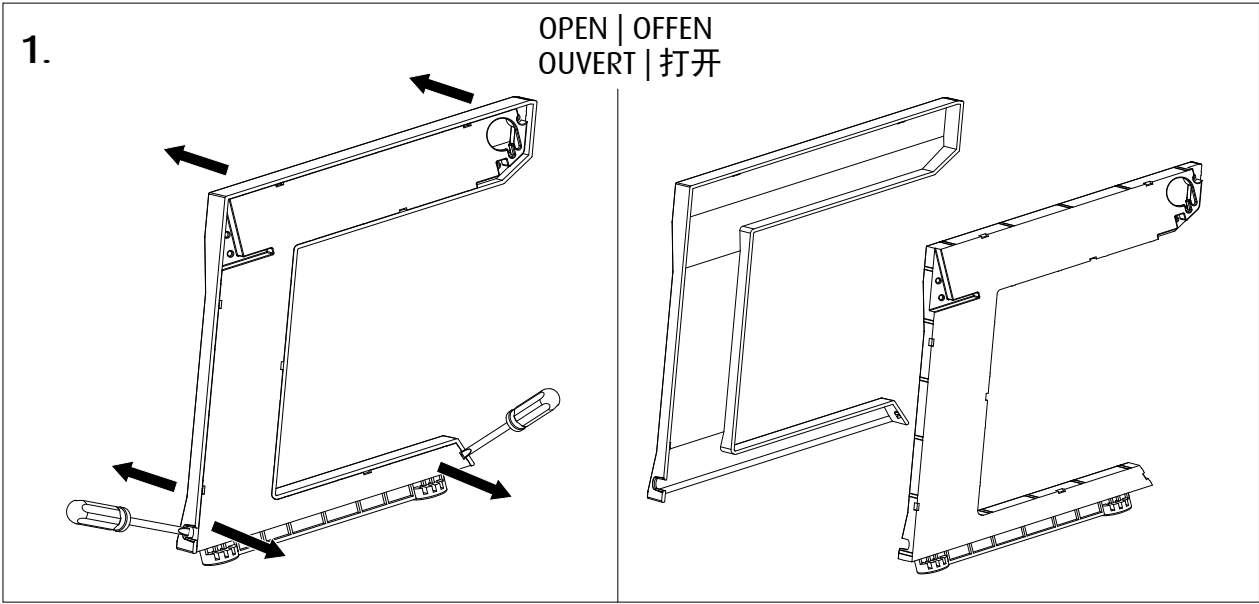

MAX® S-650

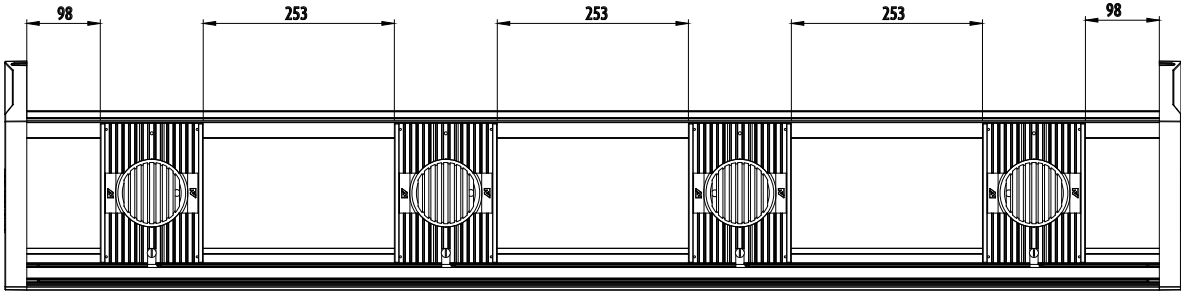

3.

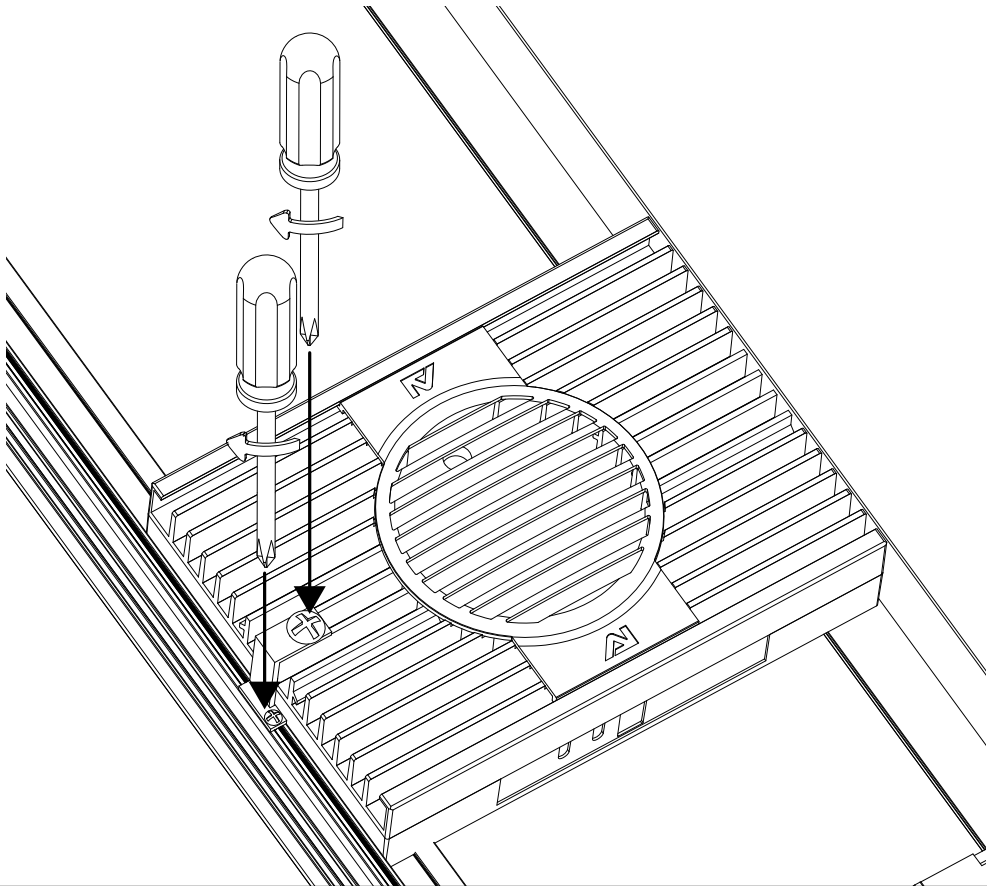
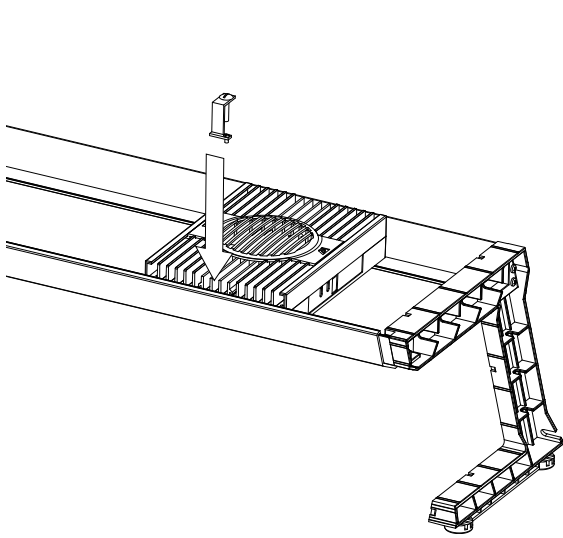
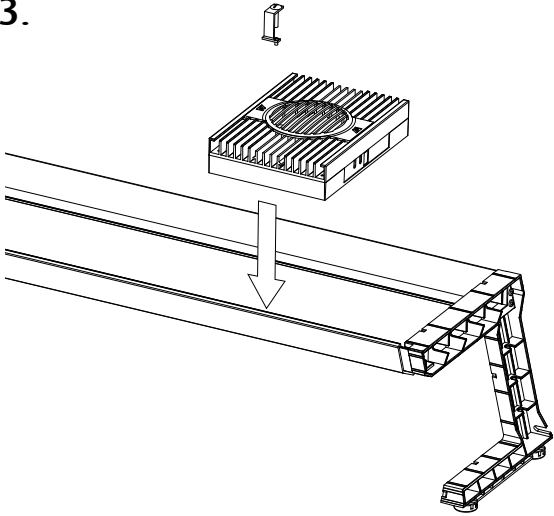

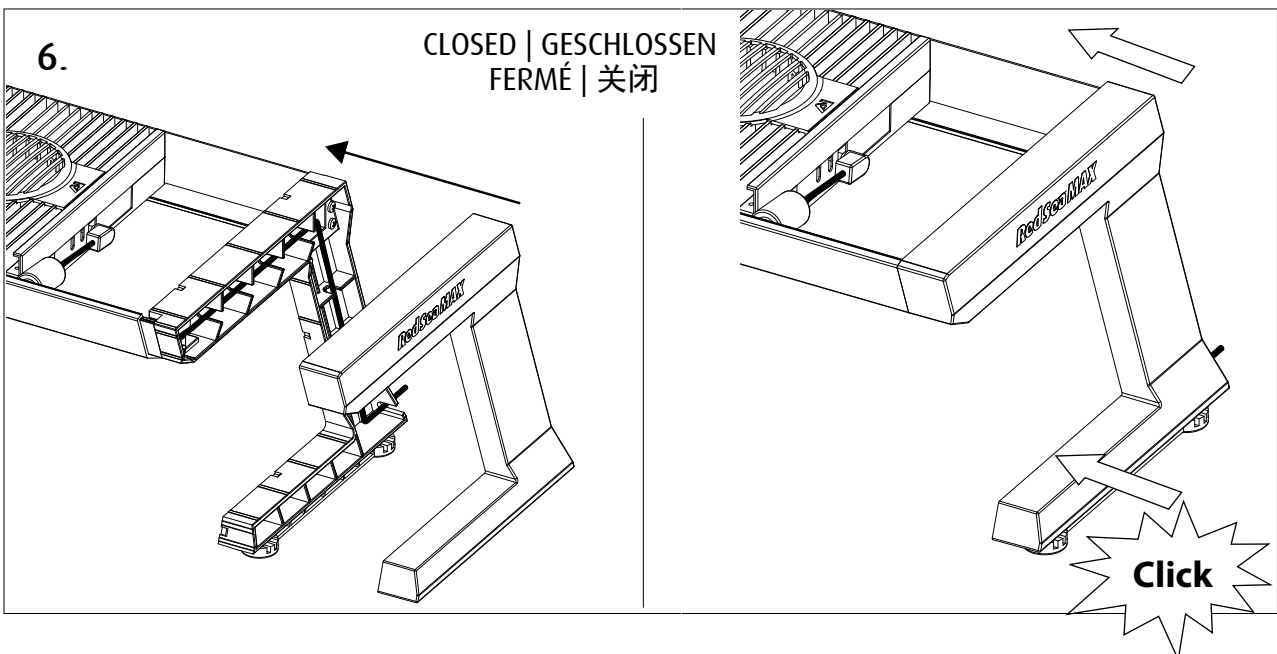
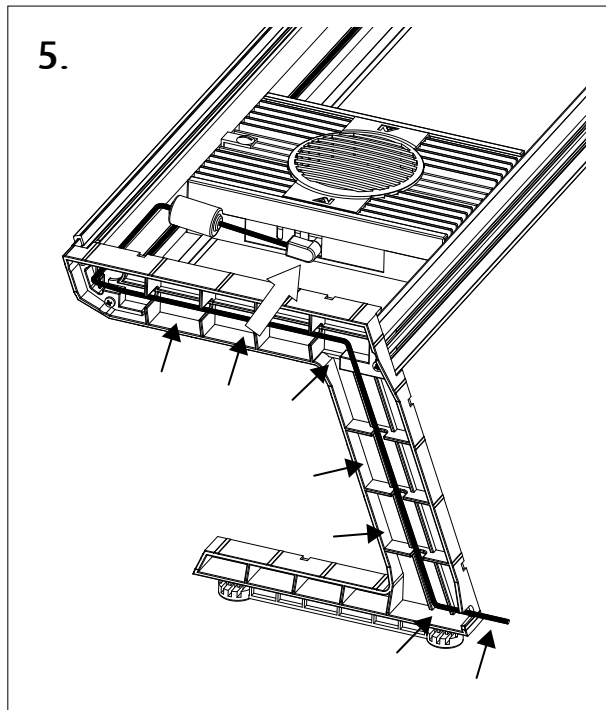
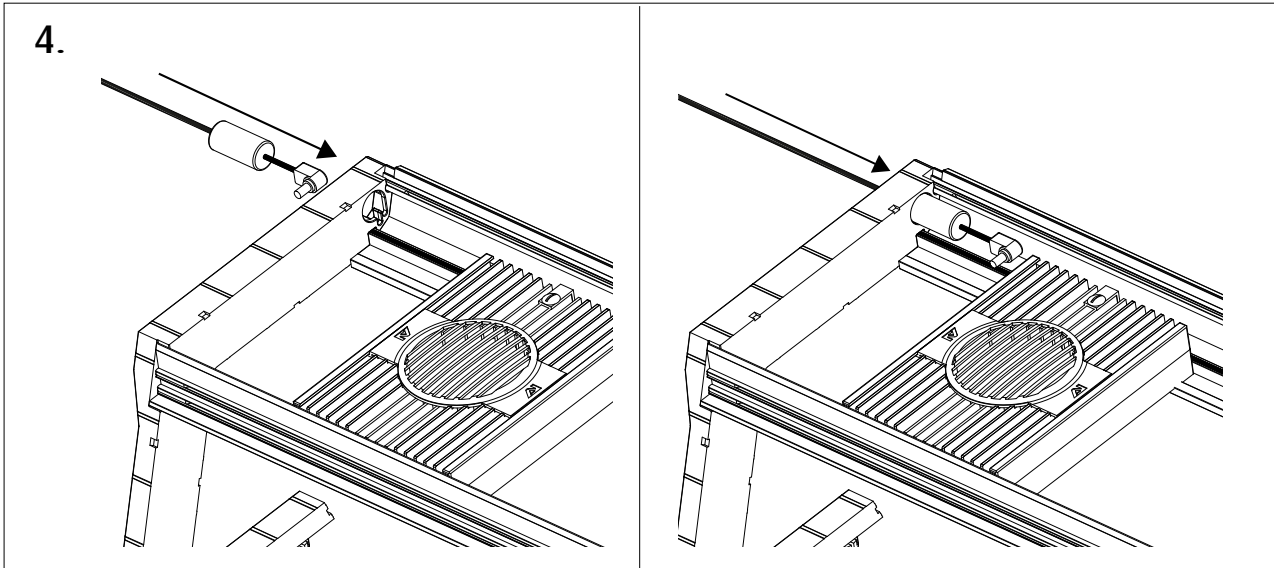

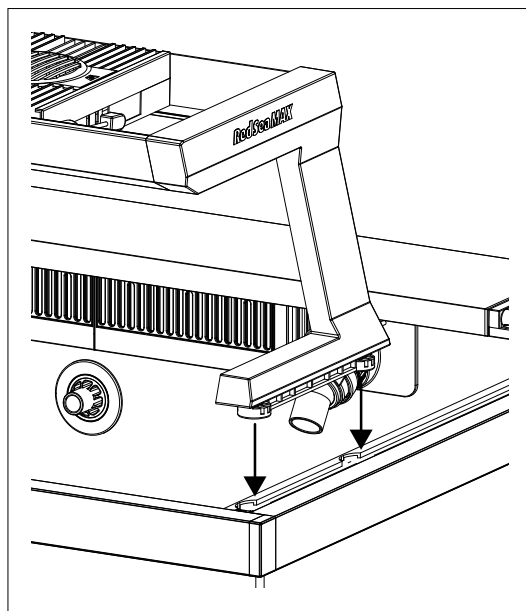
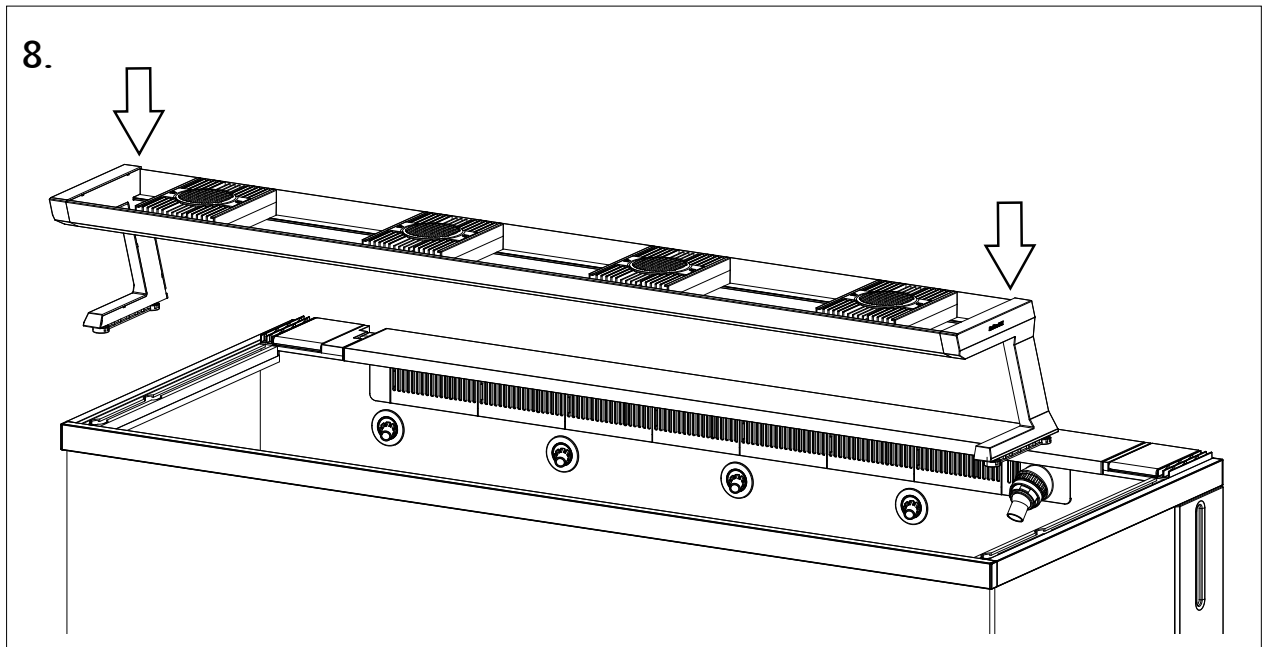
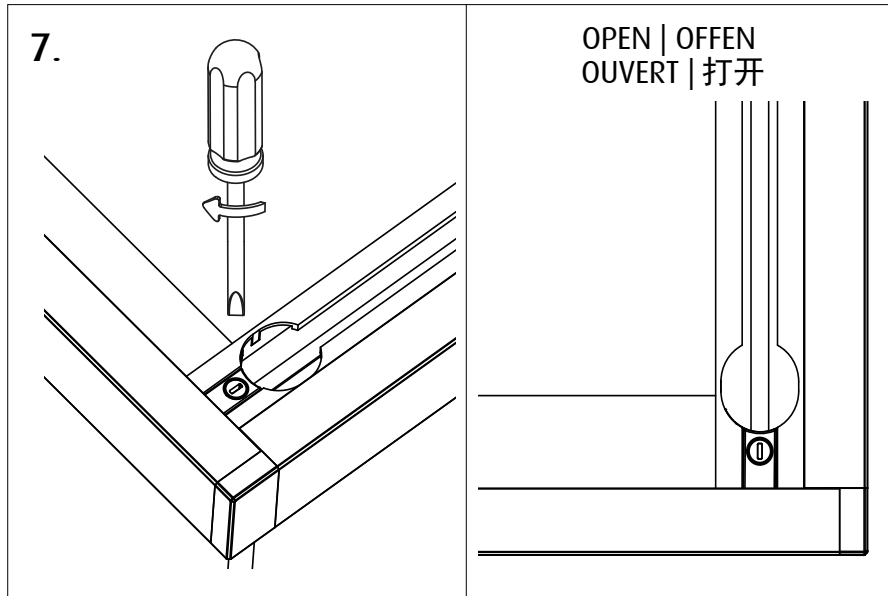

9.

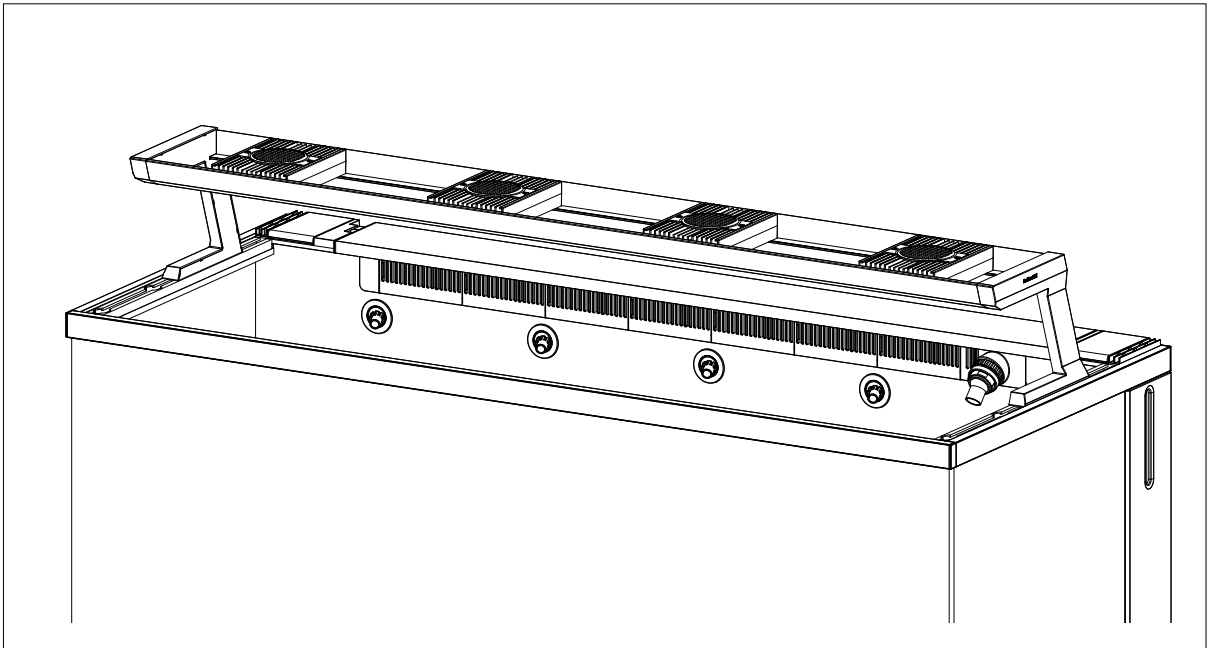
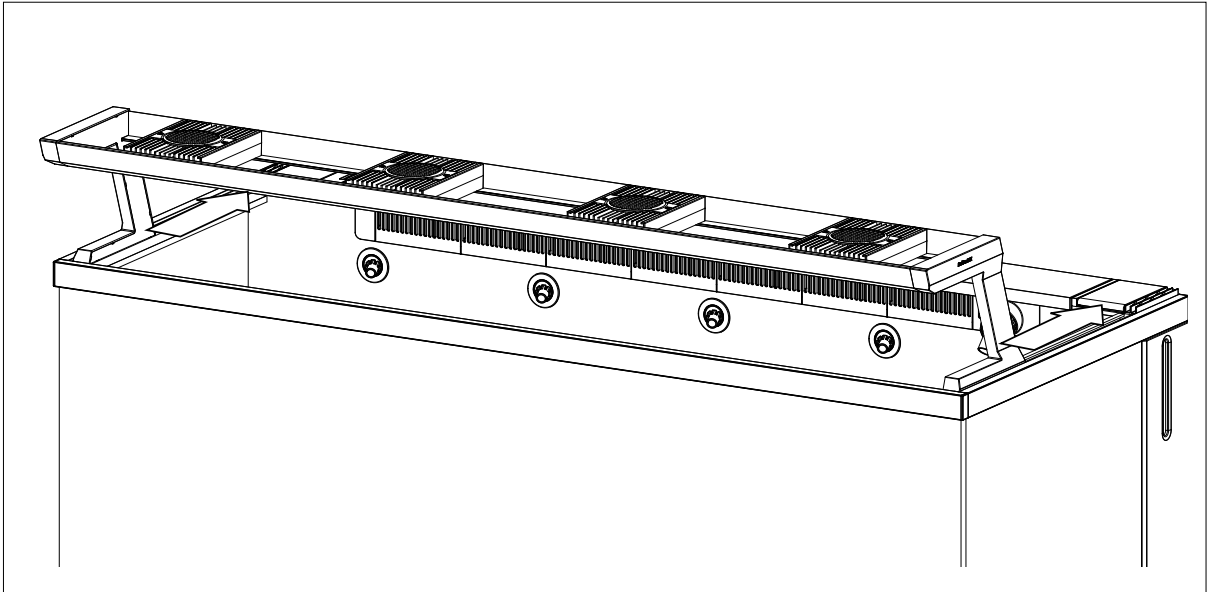

10.

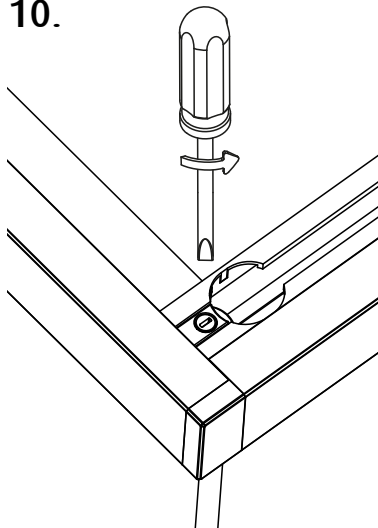

CLOSED | GESCHLOSSEN
FERMÉ | 关闭

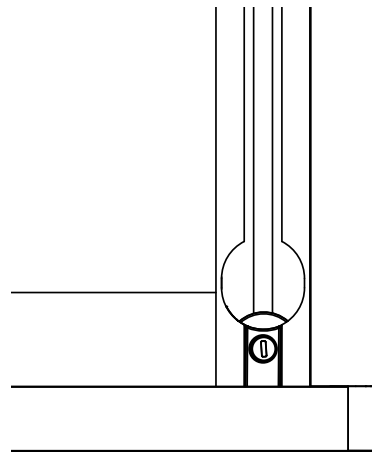

11.

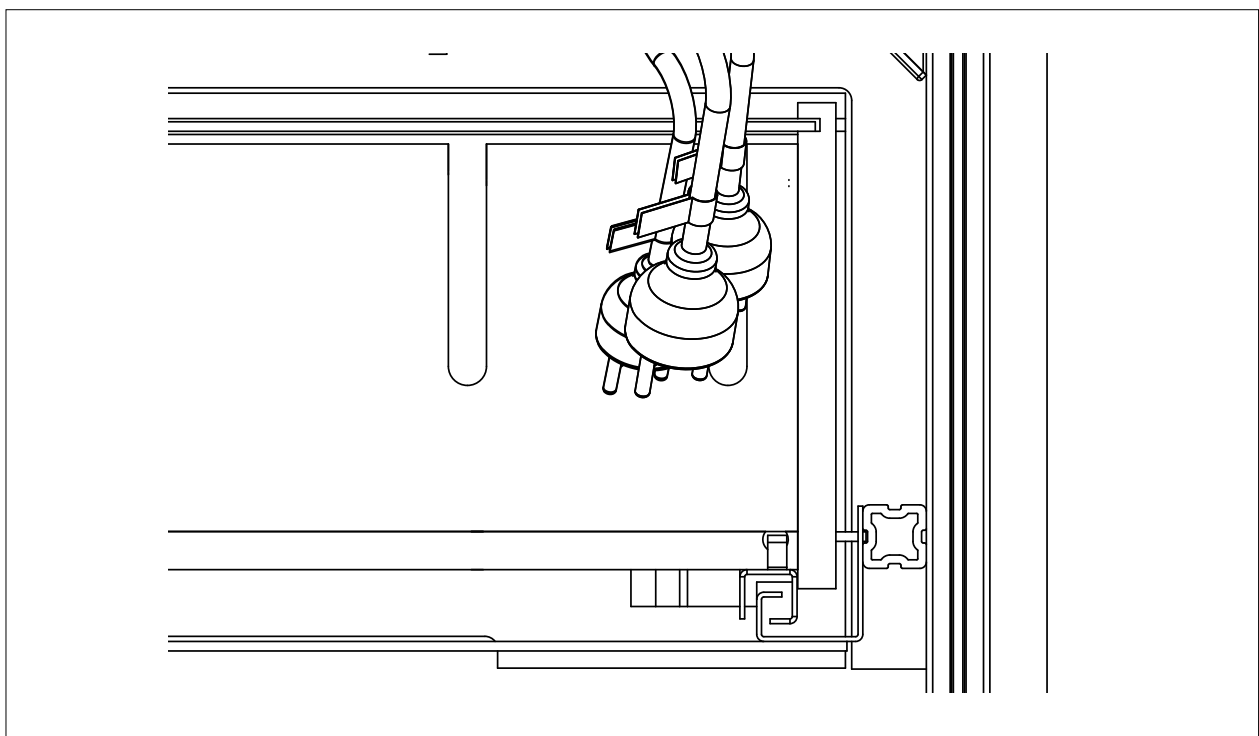
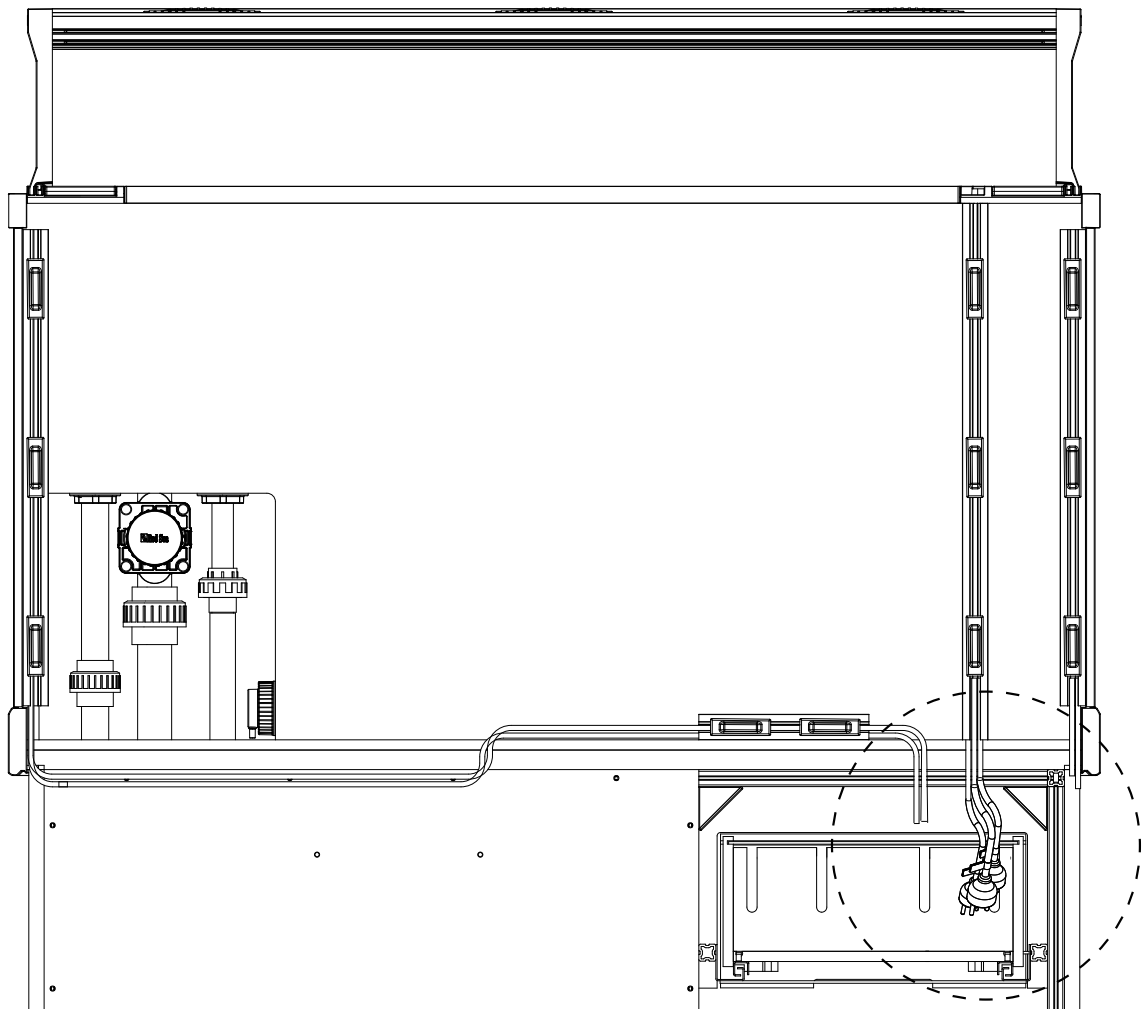

12.

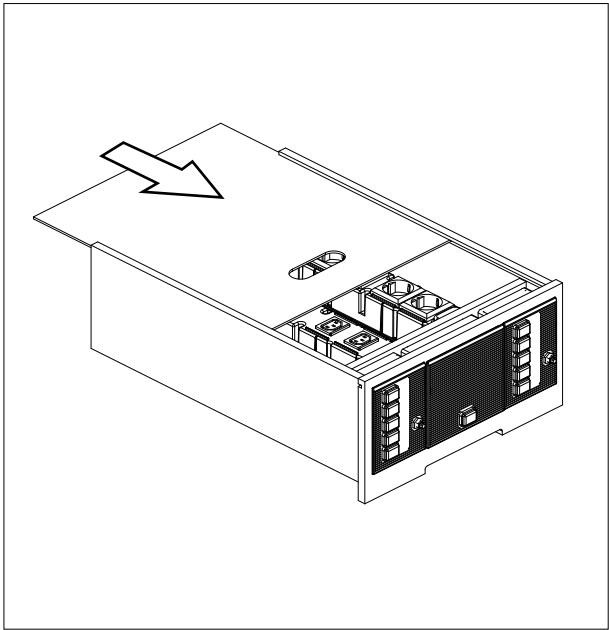
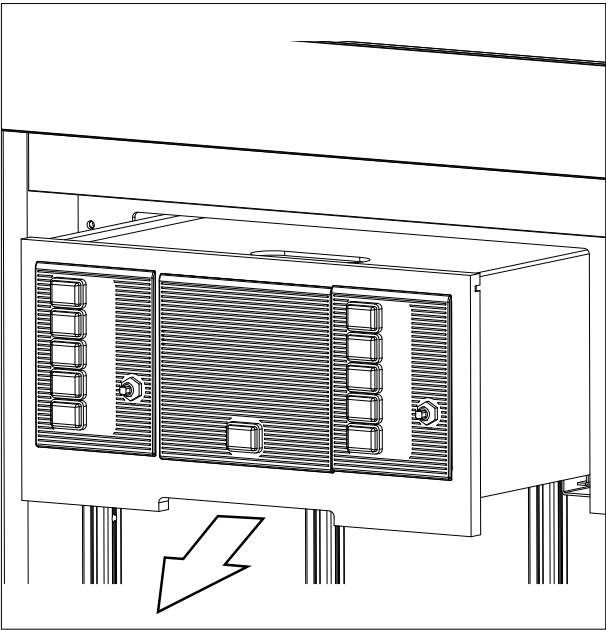
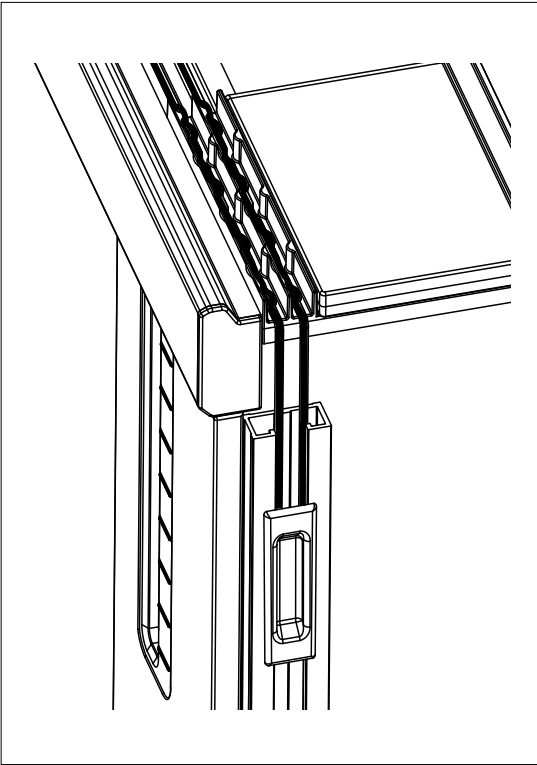
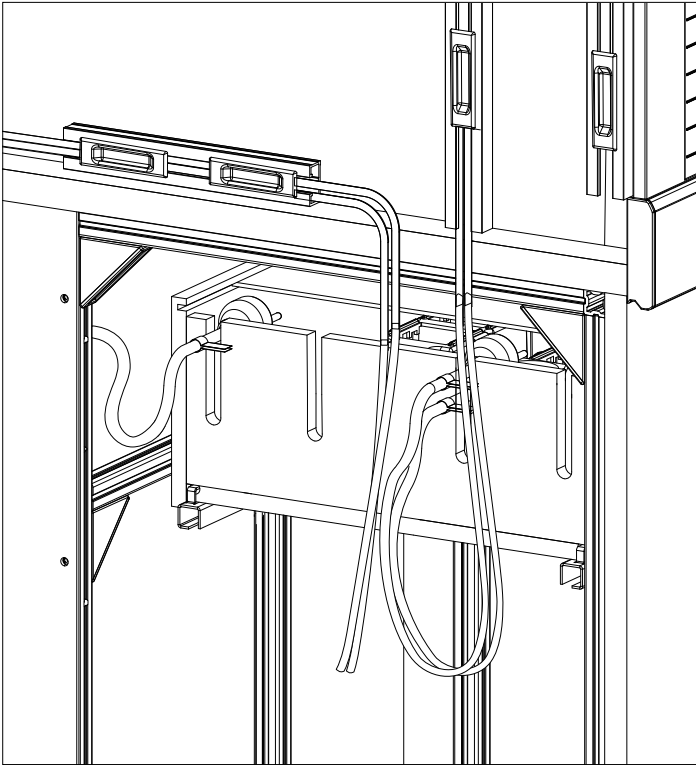

North America

Red Sea U.S.A & Canada
18125 Ammi Trail
Houston, TX 77060
Tel. : +1-888-RED-SEA9
usa.info@redseafish.com

UK & Ireland

Red Sea Aquatics (UK) Ltd
PO Box 1237
Cheddar, BS279AG
Tel. : +44 (0) 203 3711437
Fax : +44 (0) 800 0073169
uk.info@redseafish.com

Europe

Red Sea Europe
ZA de la St-Denis
F-27130 Verneuil s/Avre,
France
Tel: (33) 2 32 37 71 37
eur.info@redseafish.com

Germany & Austria

Red Sea Deutschland
Büro Deutschland
Prinzenallee 7 (Prinzenpark)
40549 Düsseldorf
Tel: 0211-52391 481
info.de@redseafish.com

Asia Pacific

Red Sea Aquatics Ltd
2310 Dominion Centre
43-59 Queen's Road East
Hong Kong
Tel: +86-020-6625 3828
info.china@redseafish.com

China

Red Sea Aquatics (GZ) Ltd.
Block A3, No.33 Hongmian Road,
Xinhua Industrial Park,
Huadu District, Guangzhou City,
China, Postal code 510800.
Tel: +86-020-6625 3828
info.china@redseafish.com



PRINTING INSTRUCTIONS

To print **only** the LED Installation and Operation Manual, print pages 115-131.

Red Sea MAX[®] S-Series LED

Complete Coral Reef Systems | Installation & Operation Manual



Index:

Introduction 3
Safety 4
Location 5
Assembly 6
Operation 13
Maintenance 16
Warranty..... 17

MAX[®] S-Series LED

Installation & Operation Manual

Introduction

Congratulations on your purchase of the Red Sea MAX[®] S LED complete reef system.

Red Sea developed the MAX[®] to provide a complete reef spec system so that from the beginning, you can focus on the aquarium's inhabitants rather than the hardware.

The Red Sea MAX[®] approach to the coral reef experience is to create an environment that is specifically attuned to the need of corals and all reef inhabitants on an artificial reef. In the ocean coral reefs flourish only where specific physical conditions prevail, such as sufficient light, adequate current, stable temperature and water clarity.

The Red Sea MAX[®] provides a system that creates the conditions that enables you to keep a thriving, healthy reef in your own home.

This manual contains the installation and operational instructions for all of the MAX[®] S aquariums.

We hope that you enjoy your MAX[®] and wish you happy reefing.

To benefit from product update information and exclusive special offers to registered MAX[®] owners, please register your MAX[®] on-line at redseafish.com

Safety

PLEASE READ AND FOLLOW ALL SAFETY INSTRUCTIONS

DANGER: To avoid possible electric shock, special care should be taken when handling a wet aquarium. For each of the following situations, do not attempt repairs yourself; return the appliance to an authorized service facility for service or discard the appliance.

WARNING: To guard against injury, basic safety precautions should be observed, including the following:

Do not operate any appliance if it has a damaged cord or plug, if it is malfunctioning, or if it is dropped or damaged in any manner.

If the external cable is damaged, it shall be replaced by the manufacturer.

To avoid the possibility of the appliance plug or receptacle getting wet, position the aquarium stand and tank to one side of a wall mounted receptacle to prevent water from dripping onto the receptacle or plug. You should create a "drip loop" (see Figure 1) for each cord connecting an aquarium appliance to a receptacle. The "drip loop" is that part of the cord below the level of the receptacle, or the connector. Use an extension cord, if necessary, to prevent water traveling along the cord and coming into contact with the receptacle. If the plug or receptacle does get wet, **DO NOT** unplug the cord. Disconnect the fuse or circuit breaker that supplies power to the appliance. Then unplug the device and examine for presence of water in the receptacle.

Close supervision is necessary when any appliance is used by or near children.

To avoid injury, do not contact moving parts.

Always unplug an appliance from an outlet when not in use, before putting on or taking off parts, and before cleaning. Never pull the cord itself to remove the plug from the outlet. Grasp the plug and pull to disconnect.

Do not use an appliance for anything other than its intended use. The use of attachments not recommended or sold by the appliance manufacturer may cause an unsafe condition.

Do not install or store the appliance where it will be exposed to the weather or to temperatures below freezing point.

Make sure an appliance mounted on a tank is securely installed before operating it.

Read and observe all the important notices on the appliance.

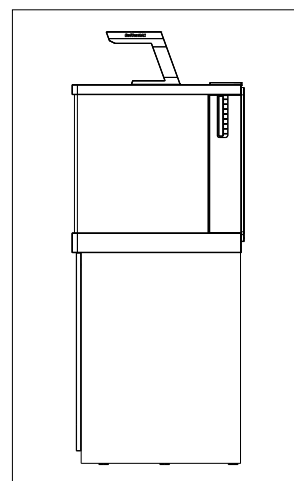

Figure 1: Drip Loop

NOTE: A cord rated for less amperes or watts than the appliance rating may overheat. Care should be taken to arrange the cord so that it cannot be tripped over or pulled accidental.

Location

The first step in setting up the MAX® S is to choose a suitable location.

Weight

The MAX® S aquariums are supported by 9-12 adjustable feet (depending on model). The flooring directly below the legs must be rated for a static loading of at least 15 kg / cm² (220 lbs/square inch).

Room temperature

Site selection is important for correct temperature maintenance. We recommend that you keep the ambient room temperature a comfortable and stable 22°C / 72°F. Avoid placing the tank in front of an air conditioner, heating vents or direct sunlight. A well ventilated room with moderate light is the best place to position the aquarium.

Accessibility

- **Back:** Ensure that there is at least 15cm / 6" of clearance behind the MAX® to allow for operation and maintenance of the flow valve on the main downpipe as well as sufficient air circulation for a chiller.
- **Sides – Rear:** Ensure that there is sufficient room (approximately 60cm / 24") between both sides of the aquarium and any adjacent walls or furniture for access to the rear of the tank. In addition to the regular maintenance of the surface skimmer, pumps and return flow vents of the rear chamber, specific access is required as follows: Left side - filling of Top-up water reservoir, installing/removing cables to power drawer. Right side – adjustment and maintenance of down-flow valve.
- **Sides – Front:** Ensure that there is approximately the length of the tank free on at least one of the sides. This is to enable the installation/replacement of the color trim on the tank as well as being able to replace the tubes in the front and rear light units without having to remove it from the aquarium.

General considerations:

Ensure that the area surrounding the aquarium is waterproof and consider moving away anything that water might damage or may be corroded by the salt.

NOTE: The MAX® S system should not be moved when full of water.

Assembly

Detailed instructions for the complete assembly of the MAX[®] S can be found in the accompanying graphic manual. It is important to assemble the MAX[®] S in the order indicated. The following information compliments the graphic manual.

If you are planning on pre-assembling the cabinet before transporting the MAX[®] S to its final location, complete only the stages 1 & 2 as per the graphic manual.

NOTE: Left and Right designations are when looking from the front of the Aquarium.

Tools

The assembly requires the following tools:

- Adjustable torque Power Drill/Driver (at least 12V) with a crosshead bit on a 5cm / 2" extension.
Do not use an impact power driver
- Regular crosshead and flat screwdrivers
- Rubber Mallet
- Spirit level (at least 60cm / 2")

Components

- The MAX[®] S system includes the following main components:
- MAX[®] S type glass aquarium with integral top-up reservoir
- Cabinet (self-assembly)
- MAX[®] S LED lighting unit
- Power Center
- Glass Sump including micron filter bags, Carbon media and Float valve for automatic top-up
- Internal Piping
- C-Skim 1800 Protein Skimmer
- Main return pump
- Circulation pumps (number according to model)

Color pack:

- Cabinet sides and doors
- Trim pack for aquarium, cabinet and lights

Cabinet assembly

WARNING: If you are not experienced in the construction of self assembly furniture, seek suitably qualified assistance.

The parts of the frame are connected by screwing self-tapping screws through the corner brackets into pre-drilled holes in the aluminum profiles. This is best achieved by using a power drill with an adjustable torque. It is necessary to apply pressure when screwing self tapping screws into aluminum. To ensure that all screws of the frame are properly seated the manual shows turning the frame around during the various stages of assembly so that pressure can easily be applied by screwing downwards while the parts are supported by the floor.

When screwing into plastic parts such as the aquarium base board or the lower front plinth, use a hand screwdriver and not the power driver.

NOTE: The upper and lower plinths are part of the color trim pack.

The adjustable feet on the bottom of the cabinet enable the system to be leveled irrespective of the flatness of the floor. When assembled the height of the feet can be adjusted so that the bottom edge of the side panels will be 6-12mm (1/4" - 1/2") above the floor. Initially assemble the 4 corner feet to the highest position and all other feet to be touching the stainless steel foot plates.

Placing Aquarium

Before placing the aquarium in its operating position familiarize yourself with top-up reservoir outlet, main pump and down pipe connections and the flow control valve that are located at the back right corner of the aquarium. Once the system is in its operating position approximately 15cm (6") from the wall, the valve and connectors are accessible from the side.

WARNING: Lifting the glass aquarium onto the cabinet will require at least 4 people. The top of the cabinet is approximately 92cm / 36" from the floor. The table shows the approximate weights of the different models of MAX® S aquarium. Ensure that anyone lifting the aquarium is physically suitable for such an operation and has been instructed in the correct methods of lifting heavy objects.

Approximate weights of Aquarium Glass		
Model	Metric (kg)	Imperial (lb)
S-400	100	220
S-500	120	265
S-650	140	310

Aquarium must be lifted from the bottom.

Take care not to damage the plastic rim on the front and sides at the top and bottom of the glass. Some damage to the rim will not affect the assembling of the external color trim.

Before lifting aquarium, place the assembled cabinet in the final operating position (see location above) and set the glass aquarium in position on top.

The back of the glass should be flush with the rear edge of the cabinet top board. The front and sides of the glass should protrude slightly beyond the edges of the cabinet board such that the protrusion is approximately even on both sides. Incorrect positioning of the aquarium on the cabinet will interfere with the assembly of the color trim.

Once the aquarium is correctly aligned with the cabinet, check that the cabinet has not moved. If necessary readjust the position of the cabinet.

Leveling Aquarium

The spirit level can be placed on the plastic rim that is around the top or bottom of the glass. To raise or lower the aquarium use the spanner provided to turn the bottom nut on the adjustable feet. The top nut is for locking the feet in position once the leveling is complete.

To level the aquarium start by adjusting the forward/ backward direction on both sides and only after both sides are level adjust the left/right alignment by raising or lowering both of the feet on one side.

When both directions are level, check that you are satisfied with the distance between the side panels and the floor. If necessary raise or lower all four corner feet until you achieve the desired distance. When satisfied with the height and leveling lock the four corner feet in position by raising the upper lock nut until tight against the steel foot plate.

Now lower each of the other feet until they are properly in contact with the floor (pay special attention when on carpet) and lock each one in position with the lock nut.

Color Trim











The color trim pack contains a set of plastic parts that are painted to the designated color. Each trim pack has a corresponding color cabinet pack that includes the cabinet side panels and doors.

The trim pack includes; the upper and lower plinth that is part of the cabinet, the color trim for the upper and lower rim of the aquarium, the front panels and end caps for the lighting unit.

The color trim for the upper and lower rim of the aquarium and the front panel are fitted by sliding them on to their corresponding part on the aquarium or light. In the event that the trim does not slide smoothly carefully push the trim into position by tapping the end with the rubber mallet.

Cable identification labels

Before installing lights, pumps, skimmer or additional equipment on the aquarium place the identifier labels on the cables near to the plug. The icons on the cable labels correspond to the icons for the switches and outlets of the power center.

	Skimmer		Main Pump
	Chiller		Circulation Pump 1
	Accessory 1		Circulation Pump 2
	Accessory 2		Circulation Pump 3
	Heater		Circulation Pump 4

Sump, pumps and piping

Feature \ Model	S-400	S-500	S-650
Number of circulation pumps	2	3	4
Main Pump L/Hr (gph)	7000 (1850)	7000 (1850)	7000 (1850)
Main pump feeds Chiller	Yes	Yes	No
Chiller return pipe provided	No	Yes	Yes
Plugged outlet for additional reactor	No	Yes	Yes
Space in sump for additional reactor	No	Yes	Yes

Top up water reservoir outlet connector – Remove the outlet connector by rotating it anti-clockwise. Pass the grey tube through the cut-out in the aquarium base and attach it to the hose-barb of the outlet. Before returning the outlet to the reservoir, ensure that the O-ring is in place. Rotate the outlet connector clockwise firmly to ensure a good seal.

Top up water in-line flow valve and float valve - During installation set the flow valve in the fully closed position and the float valve to give the lowest water level in the pump chamber.

Piping - Ensure that the O-rings are in place before connecting the universal connectors for the piping. During installation it is recommended to set the sump piping valves in the closed position. They should only be opened after the downstream equipment such the skimmer or chiller has been installed.

Main Pump – install the 32mm (1½”) elbow on the inlet of the pump so that water intake is from the bottom of the sump. Pass the power cable through the cut out at the top rear left corner of the sump compartment.

Skimmer – Ensure that the skimmer shelf is installed in the sump with the rubber side up. Full installation and operation instructions for the C-Skim 1800 protein skimmer are provided in a dedicated instruction manual. Initially set the air valve on the skimmer to the closed position. Pass the power cable through the cut out at the top rear left corner of the sump compartment.

Carbon - Wash the carbon filter material under running water several times to remove residual dust. It is recommended to soak it in water for 24-72 hr. before usage otherwise during the first 3 days after set-up the carbon may float and release micro air bubbles from inside its pores.

Lighting

The MAX[®] S LED lighting system is designed specifically for the MAX[®] S LED aquariums and should be used in conjunction with the MAX[®] S LED power center. To ensure its overall safety each component of the system is locked in place on the lighting chassis

The complete lighting unit is designed to slide easily front/back to give full access to the top of the aquarium.

The LED modules have a built-in Wi-Fi network and must be connected to a smartphone or Wi-Fi enabled computer to get the benefits of all of the features. To set up and program the LED's follow the instructions provided with the LED modules.

Programming guidelines:

Photoperiod: Day/moonlight

The day photoperiod should be between 8 – 12 hours with no more than 4 hours at maximum intensity and at ramp up/down rate of approximately 25% (of maximum intensity) per hour. Corals and fish must have daily periods of darkness. LED moonlight should be limited to 1% of the maximum light intensity for a maximum period of 6 hours.

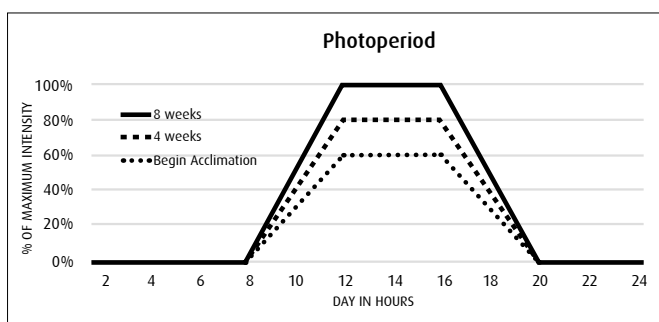

Acclimation

To prevent photo-inhibition due to the high intensity of LED lights, an acclimation period is recommended for new systems or when introducing new corals.

Acclimation will vary for different kinds of corals however it is recommended to allow a period of 8 weeks for new set-ups as follows:

Set the day photoperiod as described above however the 4 hour peak intensity should not exceed 60% of maximum. Increase the peak intensity by 10% every 2 weeks.

During the acclimation period look for signs of photo stress and photo-inhibition such as:

- Whitening/Bleaching of the upper section of the tissue (the lower section will continue to show pigments and zooxanthellae).
- Polyps retraction.
- Gas bubbles inside the soft tissue.

In the event of any of the above symptoms immediately reduce the peak intensity by 20% for about 4 weeks and thereafter increase by 5% per week until maximum intensity is reached.

When introducing new corals to already acclimated systems, start by positioning them at the lower levels of the aquarium and gradually raising them to their desired position over a period of several weeks. Keep watching for signs of photo inhibition/stress and if necessary return an affected coral to lower levels for recuperation.

NOTE: Red and Green wavelengths are not recommended for use in Reef systems as they may promote the outbreak of unwanted Algae or Cyanobacteria.

Power Center

Assemble the Power Center (PC) drawer in the cabinet by laying the drawer on the sliders and push into position. There are 2 catches on the underside of the drawer that “click” when the drawer is attached properly to the sliders. To remove the drawer, release the 2 catches on the underside of the drawer and pull the drawer off of the sliders.

The PC includes 3 individual power strips, each of which can be removed for service without affecting the functionality of the others. Protected by a resettable thermal circuit breaker which will only neutralize the specific strip. The left and right strips are identical and provide 5 individually switched outlets on each that are protected by a resettable thermal circuit breaker which will only neutralize the specific strip. The center strip is for the LED lighting. The main switch on the front panel shuts down the complete strip.

Connect the main power cable to the inlet socket of the left strip and direct the cable out of left slot on the back of the drawer. Ensure that all of the switches on the front panel are in the off position. Do not connect the main power cable to the power until the aquarium and sump are filled with water.

To connect equipment to the PC:

IMPORTANT: Before opening the PC ensure that your hands are dry and that there is no water dripping down the front glass of the aquarium.

1. Make sure that the lid is in the closed position (pulled to the front of the drawer) and that the drawer is in its normal operating position. All equipment is attached from the rear of the drawer.
2. Place plugs into the back section of the drawer with the cables running through one of the slots.
3. Open the drawer as far as it will go and slide the lid backwards.
4. Reach into the back of the draw and gently pull the plugs forward.
5. Insert each plug into its designated outlet.
6. Close the lid (pulled to the front of the drawer) and return the draw to its normal operating position.
7. Make sure that all of the cables at the back of the drawer are free to move as the drawer is opened and closed.

Heaters, Chillers and other accessories

Heaters and Chillers are not provided as a standard part of the MAX[®]-S however preparations have been made for their installation.

Dedicated power outlets are provided for a heater, chiller and 2 accessories in the Power center.

Chiller: The left hand compartment under the power center has been designed to house a chiller. A gap has been provided between the base board and door and the rear has been left open to allow for proper airflow for the chiller to run without overheating. The inlet and outlet pipes of the chiller should pass through the cut out at the top rear left corner of dividing wall between the sump and chiller compartments.

S-400: Connect the inlet pipe of the chiller to the chiller outlet on the main pump manifold. Place the return pipe from the chiller into the downpipe chamber of the sump with the return pipe ending under the water. Once the complete system is operational set the chiller flow valve for a flow of approximately 2000 l/h (500gph).

S-500: Connect the inlet pipe of the chiller to the chiller outlet on the main pump manifold. Connect the outlet of the chiller to the inlet of the chiller return pipe that is attached to the rear wall of the sump compartment. Add an extra piece of flexible pipe from the outlet of the chiller return pipe to the downpipe chamber of the sump with the flexible pipe ending under the water. Once the complete system is operational set the chiller flow valve for a flow of approximately 2000 l/h (500gph).

Heaters and other accessories (such as a calcium reactor) can be placed in the accessory compartment (left side) of the sump. Water to feed accessories can be taken by replacing the $\frac{3}{4}$ " plug in the main pump manifold with a suitable hose barb.

S-650: Place a 2400 l/h (600gph) feeding pump for the chiller in the accessory compartment (left side) of the sump and connect with flexible piping to the inlet of the chiller. Connect the outlet of the chiller to the inlet of the chiller return pipe that is attached to the rear wall of the sump compartment. Add an extra piece

of flexible pipe from the outlet of the chiller return pipe to the downpipe chamber of the sump with the flexible pipe ending under the water.

Heaters and other accessories (such as a calcium reactor) can be placed in the accessory compartment. Water to feed accessories can be taken by replacing the $\frac{3}{4}$ " plug in the main pump manifold with a suitable hose barb and adjusting the flow as required with the valve.

Operation

MAX[®] S Aquarium Flow Dynamics Overview

The MAX[®] S aquarium is divided into 3 parts: Main Tank, Rear Chamber and Top-up Reservoir.

The main tank and rear chamber are connected by a surface skimmer across the top of most of the length of the tank and a number of flow holes located along the back wall.

The silent-flow downpipe system includes a transparent funnel with a flow-regulated main downpipe and a secondary overflow pipe that is 25mm (1") above the main downpipe. The fine adjustment flow valve allows for the water level in the rear chamber to be maintained at a constant height without hearing the water returning to the sump. In the event of a change in flows or blockage in the main downpipe the overflow pipe will accommodate all of the water flow to the sump. An incorrect setting of the flow valve will be accompanied by the sound of the water returning to the sump and is an indication that the flow valve needs adjusting.

When all of the circulation pumps are running and the flow valve is adjusted correctly the water in the main tank will always be maintained just below the bracing bars but above the external trim so the water line in the aquarium will never be visible from the outside. The water level in the rear chamber will be maintained approximately 30mm (1¼") below the water level in the main tank ensuring a positive surface skimming at all times. The height of the water in the rear chamber can be monitored through the viewing slot at the top of the side panel on the right side of the chamber or by lifting the flap above the funnel.

Any loss of water due to evaporation will cause a drop in the water level of the sump. The float valve in the main pump compartment of the sump controls the automatic replenishment of top-up water from the reservoir. The reservoir contains water for approximately 5 days of evaporation. Top-up water is added to the reservoir at the top left corner of the rear chamber. The water level in the reservoir can be monitored through the viewing slot at the bottom of the side panel on the left side of the chamber.

In the sump all water passes through 2 mechanical sponge filters before flowing into the skimmer and accessory chambers. All of the water then passes through the carbon filter media before entering the main pump chamber.

The main pump returns the water to the aquarium and a regulated portion of the flow is provided for the skimmer and in the 400/500 also to the chiller.

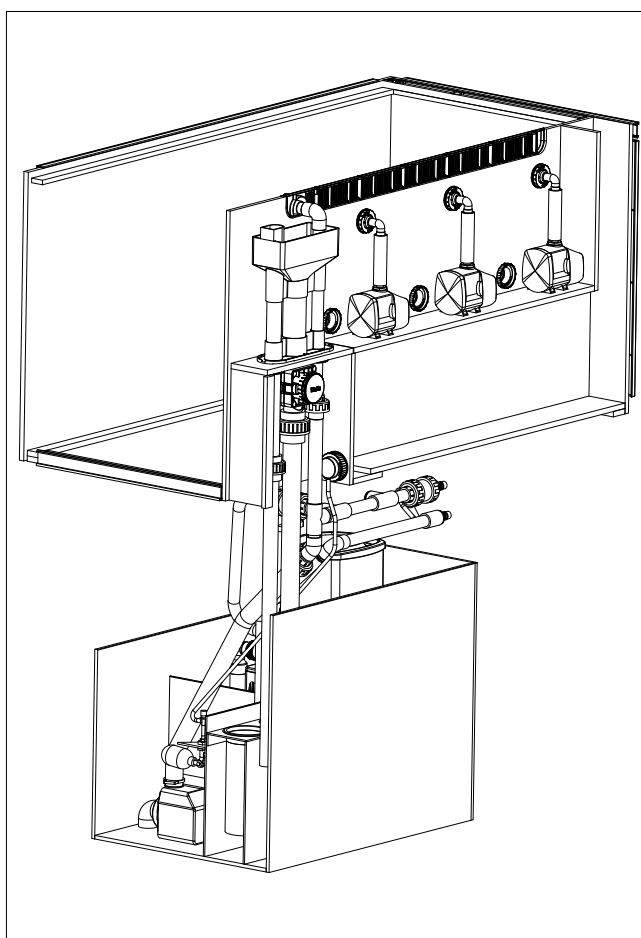

Initial Fill

Open the main flow valve (rotate anti-clockwise) to maximum.

Add water to the main tank and rear chamber and when the water is above the level of the circulation pump outlets switch them on.

Continue adding water to the main tank. Open the cabinet door and monitor the water level in the sump as it begins to fill. As soon as there is approximately 15 cm (6") of water in the main pump compartment switch on the main pump and stop adding water.

Allow the system to run for a few minutes and try to adjust the flow valve so that the water level in the rear chamber is approximately at the dotted line.

Open the valves to the skimmer (initially approximately 50% open) and any other equipment that takes water from the sump and readjust the flow valve.

Add more water to the system until the water level in the main pump chamber of the sump is approximately 20cm (8").

WARNING: overfilling the sump may cause a flood in the event of an interruption of electricity.

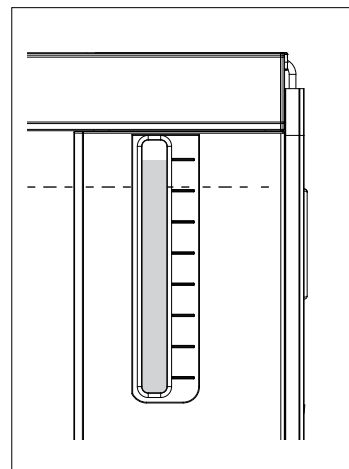

NOTE: It is advisable to do the first fill with fresh water or a weak saltwater solution to check the integrity of the system and to clear away any chemical residues from production.

Automatic Top-up System

Once the saltwater system is stable and the water height in the main pump chamber is approximately 20cm (8") adjust the angle of the float so that the valve is closed at the desired water height. Ensure that the Top-up flow valve is fully closed.

Fill the Top-up reservoir with RO water. For easy access to the fill port of the reservoir raise the rear 4xT5 light unit to the upright position and fully open the fill port flap.

Disconnect the top-up flow valve from the float valve and slowly open the flow valve until the top-up water drips at a rate of approximately 1 drop per second. Reconnect the flow valve to the float valve.

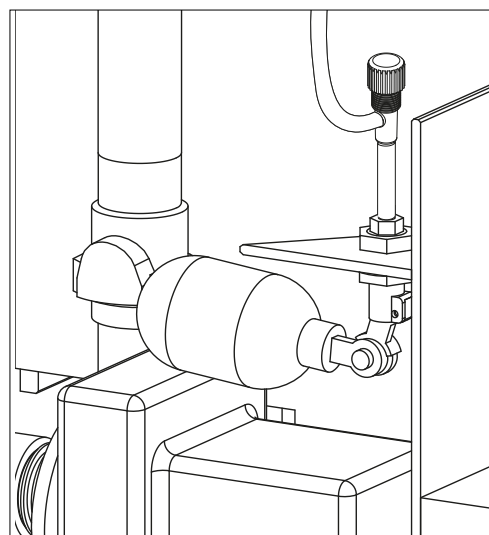

Main Downpipe Flow Valve

The main downpipe flow valve provides a very fine control of the flow rate however after making adjustments it takes the system a few minutes to stabilize at the new setting. Once you have established the approximate setting for the valve make very small adjustments and wait for a few minutes each time. It may take a number of occasional adjustments to reach a stable level. When set properly this system removes all of the noise of water flowing down to the sump.

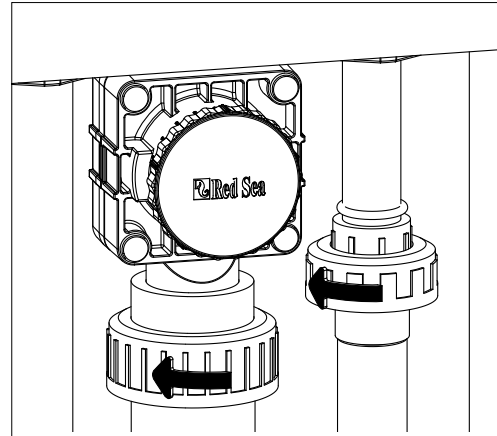

Maintenance of flow valve

To disassemble the valve, switch off all of the pumps and allow the water level in the rear chamber to drop below the rim of the transparent funnel. Once the main downpipe is clear of water, remove the 4 rubber plugs from the corners and unscrew the 4 screws with the Allan key provided. Maintain the valve assembly vertical and pull it away from the valve body. Be careful not to let the screws fall out.

In the event of calcium deposits clean both the valve body and diaphragm with a weak acidic solution (e.g. vinegar) and rinse thoroughly after treatment.

When reassembling the valve assembly on the body, ensure that all 4 screws are tight enough to give a watertight seal however do not use excessive force. Replace the rubber plugs.

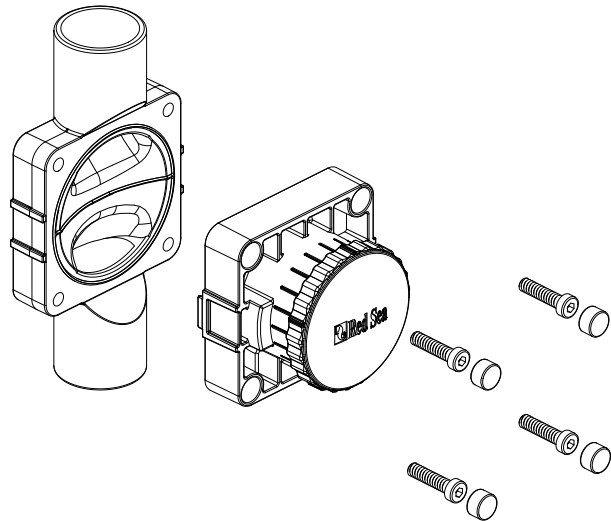

To replace the diaphragm rotate the handle clockwise and when free of the body remove the retaining pin. To reassemble rotate the handle in the opposite direction until the diaphragm is fully retracted.

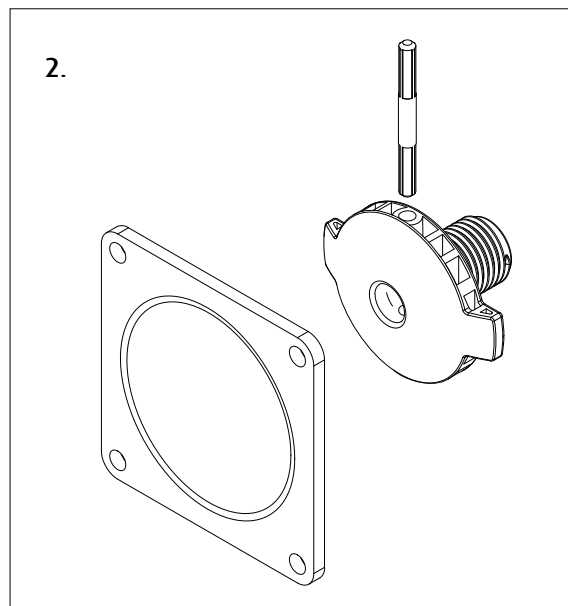
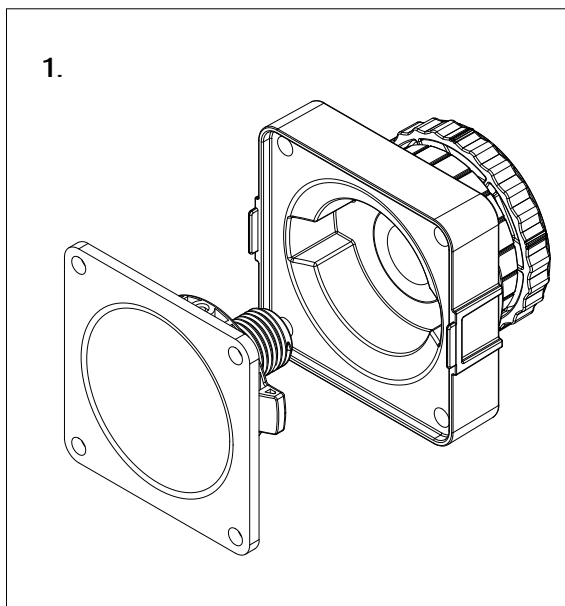

Maintenance

The long-term success and health of the inhabitants of your MAX® aquarium depends on you. Proper planning makes reef care easier to manage and quicker to perform. This will leave you more time for the real goal: enjoying your aquarium. Care of the tank should follow a regular, logical pattern. Divide the tasks into daily, weekly and monthly procedures, including equipment checks, feeding, water parameter testing and adjustments.

You may find it helpful to make a systematic checklist of care activities and keep a log of the activities performed. Your log does not need to be complicated; you will need to track the following:

- The tank's parameters – pH, salinity, temperature, etc.
- Information specific to each animal – when you added them, their approximate size, date of death (it happens in the most successful aquaria!) and possible cause, etc.
- The general appearance of the tank and individual species.
- Equipment changes.

Circulation - Maintain adequate water circulation by checking that the circulation pumps are working well and are pointed in the right directions. If you notice any regression in currents, check the inlet of each pump and the outlet nozzles for any obstructions (snails, crabs, carbon chips, etc.).

Protein skimmer functioning - Check the foam production in the collection cup and adjust the water and air flow valve as required to get stable dry foam.

Water levels - Check daily the water level in the rear chamber and adjust the flow valve as required. Check the water level in the Top-up reservoir. Check the water level in the sump. Check that the top-up float valve is operating correctly.

Water temperature control - For optimum conditions a reef aquarium should be maintained at a stable water temperature in the range of 24-28°C / 76-82°F (the stability of the temperature being more important than the exact value). Slightly higher temperatures can be tolerated for short periods of time as long as the change in temperature is steady and not sudden. Monitor the temperature at least twice a day, looking for dramatic fluctuations.

Avoid temperature differences of more than 2°C / 7°F during the day. During season changes and when heating or cooling the house, monitor the tank temperature more frequently, adjusting the heater/chiller as necessary.

Change the carbon filter - Replace the active carbon filter every two months.

Clean the pump impellers and housing - Calcium carbonate builds up on the pump motors. Every 3 months, submerge each pump in a mixture of hot water and vinegar. Remember to properly turn off and disconnect each pump.

Micron Filter bags - It is recommended to have at least 3 sets of filter bags.

There are a few options for cleaning the filter bags:

Quick and effective – Spray the outside of the bags with a powerful water jet such as a garden hose to back-flush the detritus from the felt.

More thorough – soak the bags in bleach or diluted vinegar for 24 hours prior to spraying as above. Rinse well to remove all chemicals before returning to sump.

The filter bags can also be put in a cold wash in a washing machine with regular detergent or with vinegar (may require approval from a higher authority).

Surface Skimmer - Remove and clean the combs of the surface skimmer at least once a week to allow proper water flow and stable water level differentiation between the aquarium and the rear sump. Periodically soak the combs in a weak acidic solution (vinegar, citric acid) until any calcium carbonate deposits have dissolved.

Warranty

Red Sea Aquarium Products Limited Warranty.

The limited warranty sets forth all **Red Sea Aquatics (HK) Ltd (Red Sea)** responsibilities regarding this product. There are no other express or implied warranties from **Red Sea**.

Red Sea warrants your product against defects in materials and workmanship for a period of 12 months, valid from the date of original purchase and will repair this product free of charge (not including shipping costs) with new/rebuilt parts. Damage to the aquarium glass or to the florescent tubes is not included. The precondition for the warranty is that the stipulated set-up routine is observed. In the event that a problem develops with this product during or after the warranty period, contact your local dealer or Red Sea (at the company address indicated) for details of your nearest authorized service center.

The warranty is extended only to the original purchaser. Proof of date of purchase will be required before warranty performance is rendered. This warranty only covers failures due to defects in materials or workmanship which occur during normal use. It does not cover damage which occurs in shipment or failures which result from misuse, abuse, neglect, improper installation, operation, mishandling, misapplication, alteration, modification or service by anyone other than an authorized **Red Sea** service center.

Red Sea shall not be liable for incidental or consequential damages resulting from the use of this product, or arising out of any breach of this warranty. All express and implied warranties, including the warranties of saleability and fitness for particular purpose, are limited to the applicable warranty period set forth above.

These statements do not affect the statutory rights of the consumer.

USA

Some states do not allow the exclusion or limitation of incidental or consequential damages, or limitations on how long an implied warranty lasts, so the above exclusion or limitations may not apply.

To benefit from product update information and exclusive special offers to registered MAX[®] owners, please register your MAX[®] on-line at redseafish.com



PRINTING INSTRUCTIONS

To print **only** the LED Upgrade Manual, print pages 132-141.

Red Sea MAX[®]S LED Upgrade

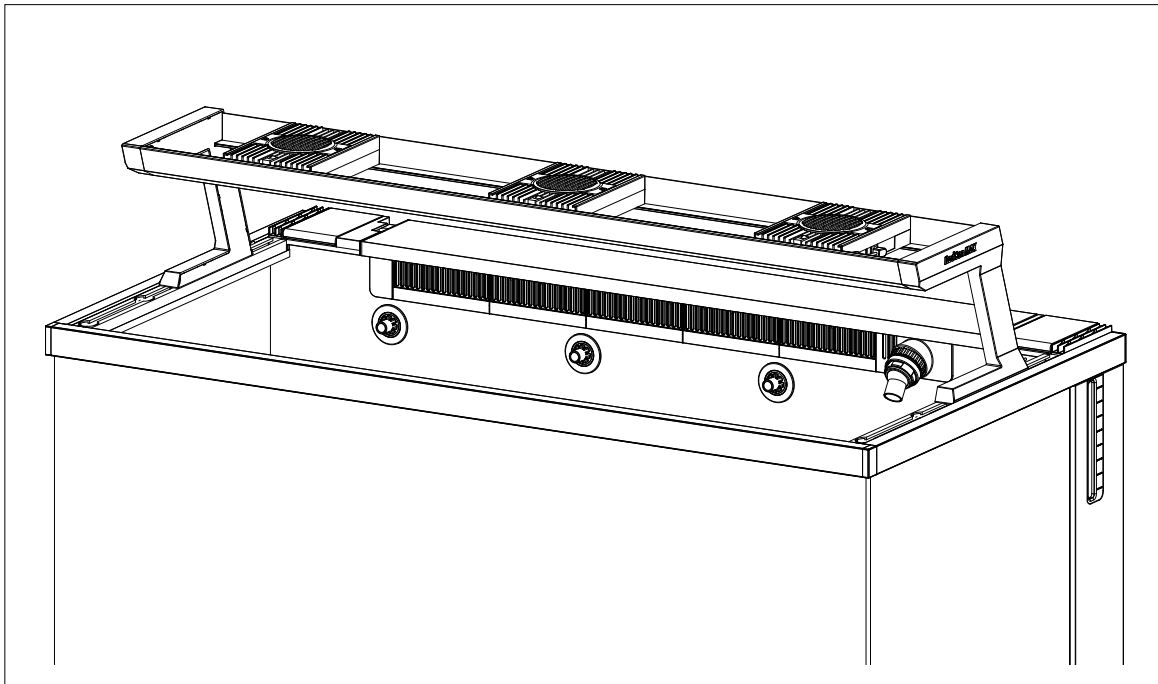

Lighting

The MAX® S LED lighting system is designed specifically for the MAX® S LED aquariums and should be used in conjunction with the MAX® S LED power center. To ensure its overall safety each component of the system is locked in place on the lighting chassis

The complete lighting unit is designed to slide easily front/back to give full access to the top of the aquarium.

The LED modules have a built-in Wi-Fi network and must be connected to a smartphone or Wi-Fi enabled computer to get the benefits of all of the features. To set up and program the LED's follow the instructions provided with the LED modules.

Programming guidelines:

Photoperiod: Day/moonlight

The day photoperiod should be between 8 – 12 hours with no more than 4 hours at maximum intensity and at ramp up/down rate of approximately 25% (of maximum intensity) per hour. Corals and fish must have daily periods of darkness. LED moonlight should be limited to 1% of the maximum light intensity for a maximum period of 6 hours.

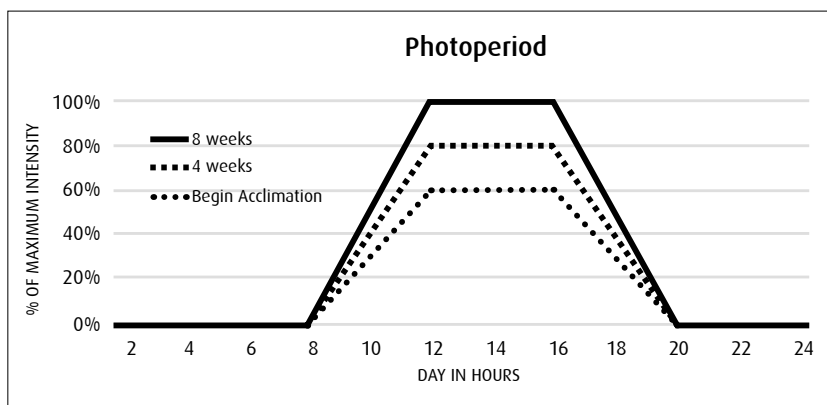

Acclimation

To prevent photo-inhibition due to the high intensity of LED lights, an acclimation period is recommended for new systems or when introducing new corals.

Acclimation will vary for different kinds of corals however it is recommended to allow a period of 8 weeks for new set-ups as follows:

Set the day photoperiod as described above however the 4 hour peak intensity should not exceed 60% of maximum. Increase the peak intensity by 10% every 2 weeks.

During the acclimation period look for signs of photo stress and photo-inhibition such as:

- Whitening/Bleaching of the upper section of the tissue (the lower section will continue to show pigments and zooxanthellae).
- Polyps retraction.
- Gas bubbles inside the soft tissue.

In the event of any of the above symptoms immediately reduce the peak intensity by 20% for about 4 weeks and thereafter increase by 5% per week until maximum intensity is reached.

When introducing new corals to already acclimated systems, start by positioning them at the lower levels of the aquarium and gradually raising them to their desired position over a period of several weeks. Keep watching for signs of photo inhibition/stress and if necessary return an affected coral to lower levels for recuperation.

NOTE: Red and Green wavelengths are not recommended for use in Reef systems as they may promote the outbreak of unwanted Algae or Cyanobacteria.

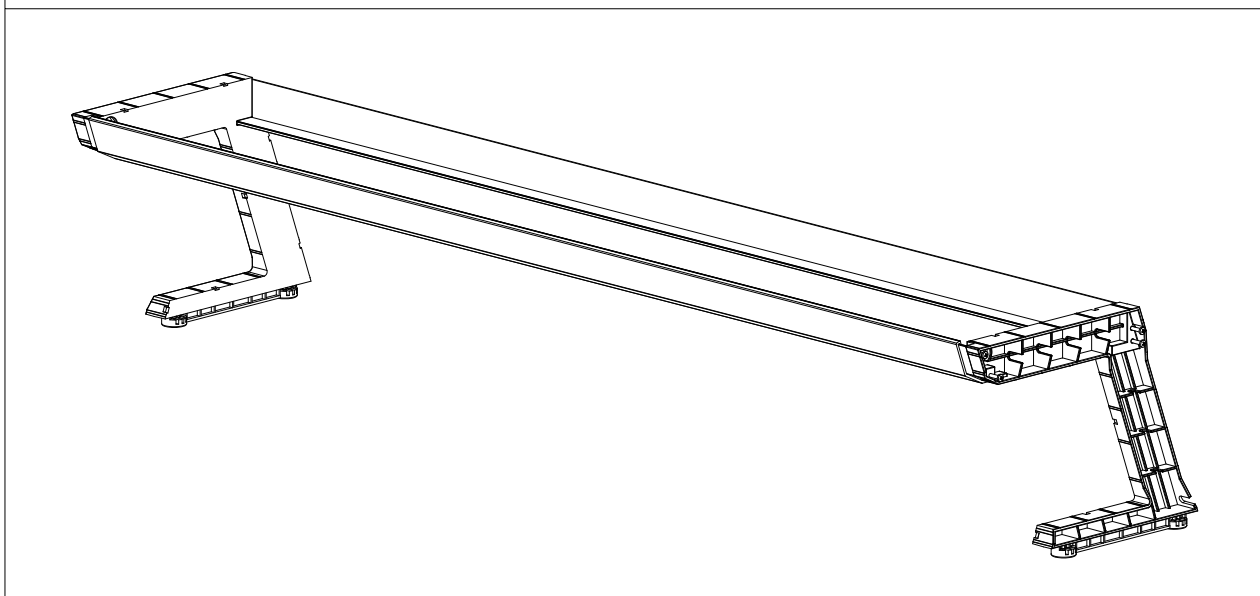
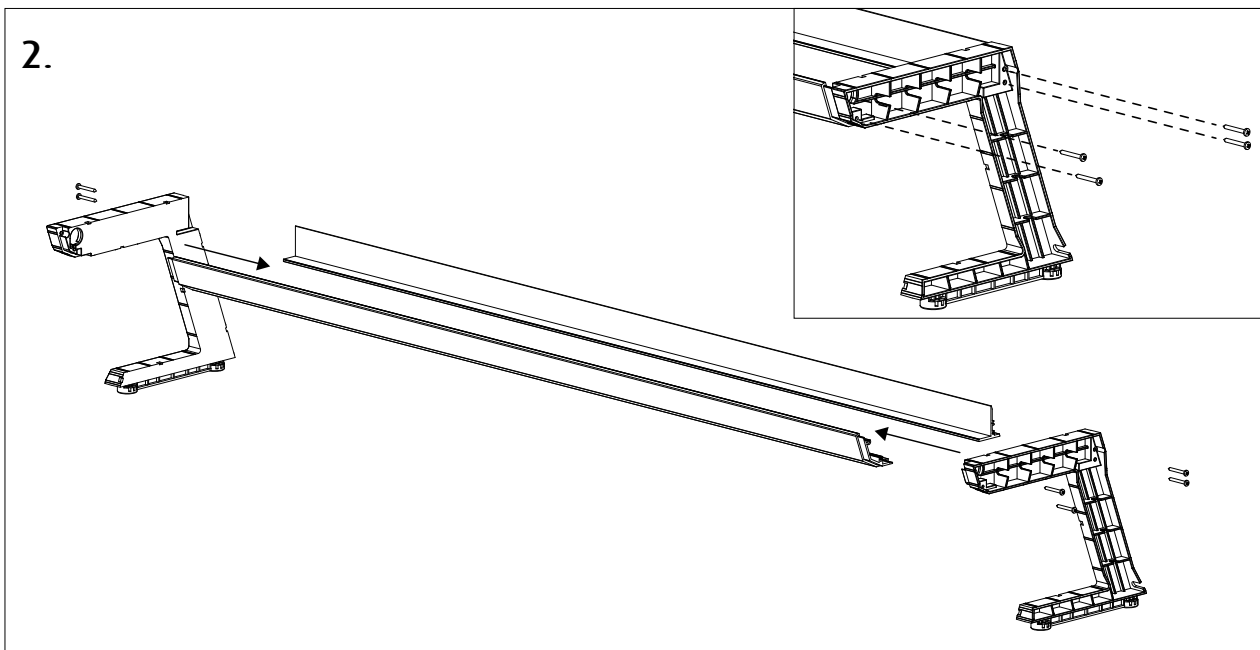
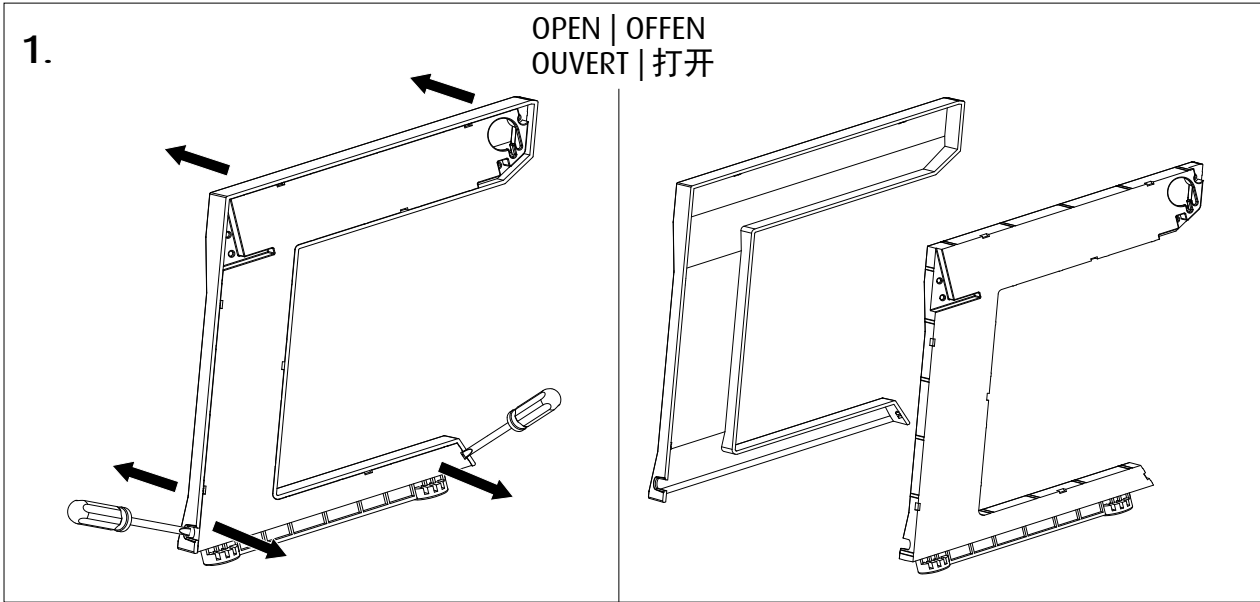

MAX[®] S-400

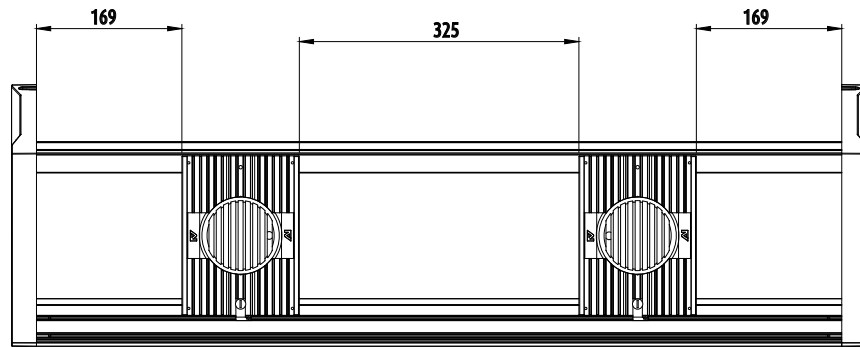

MAX[®] S-500

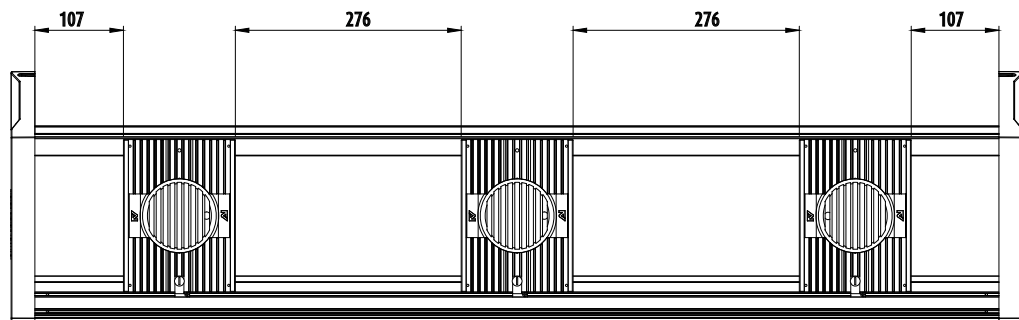

MAX[®] S-650

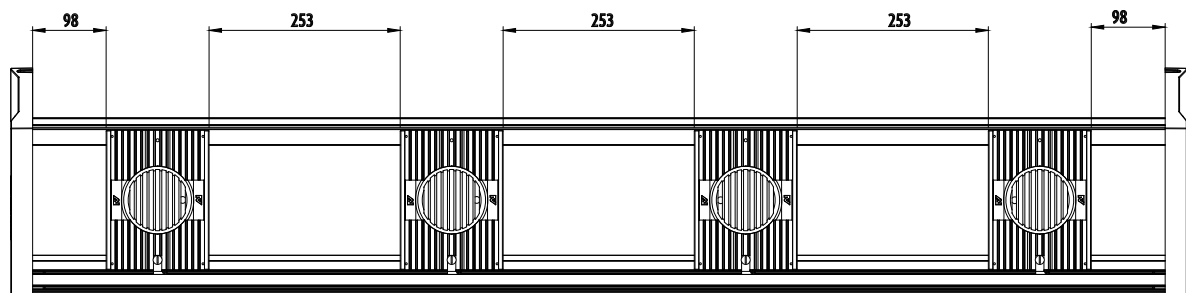

3.

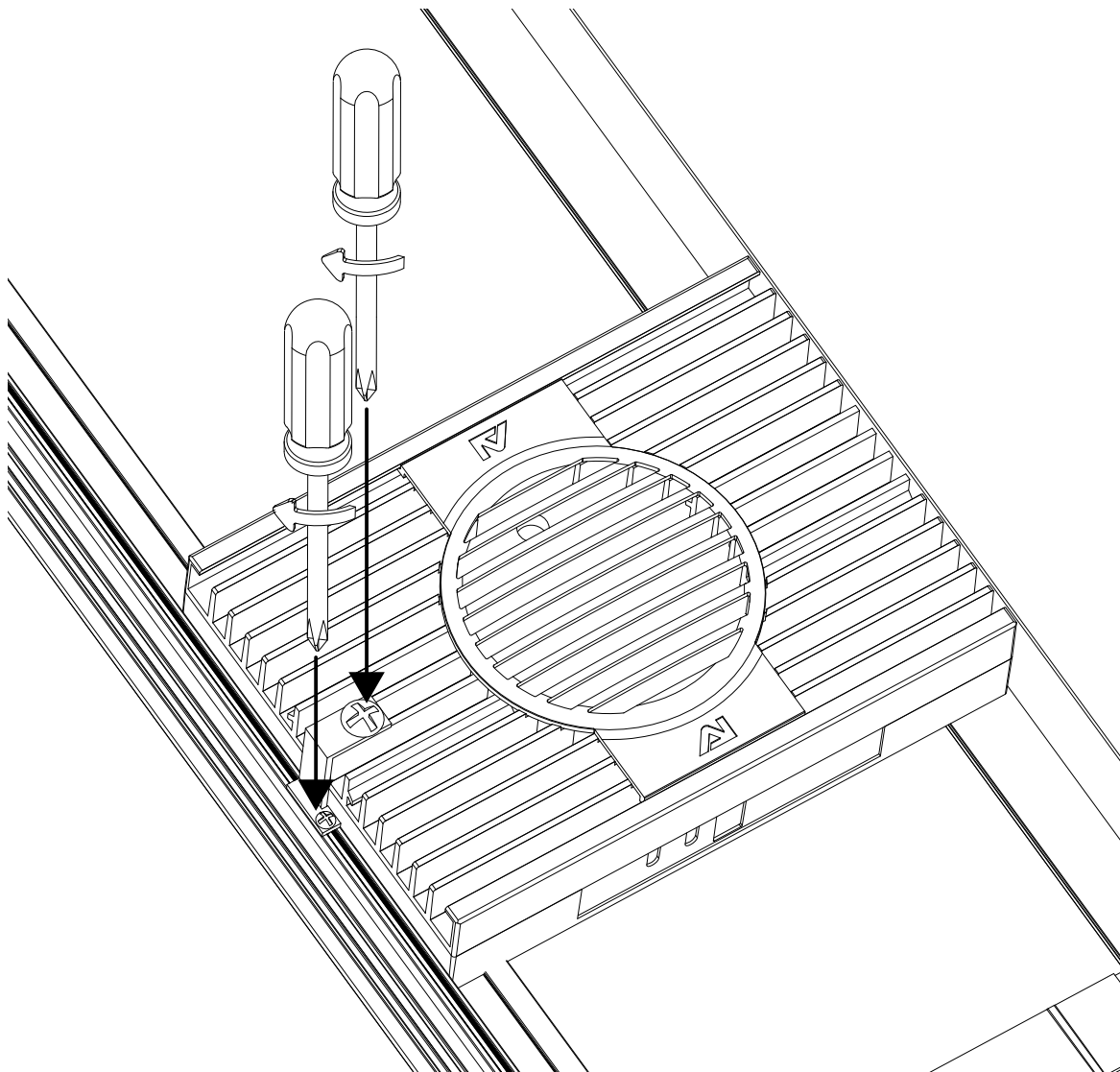
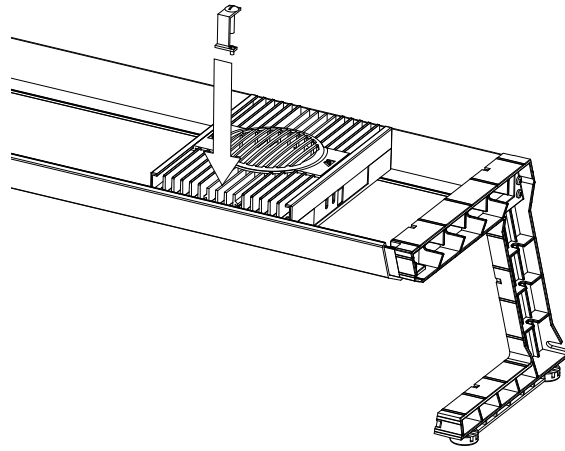
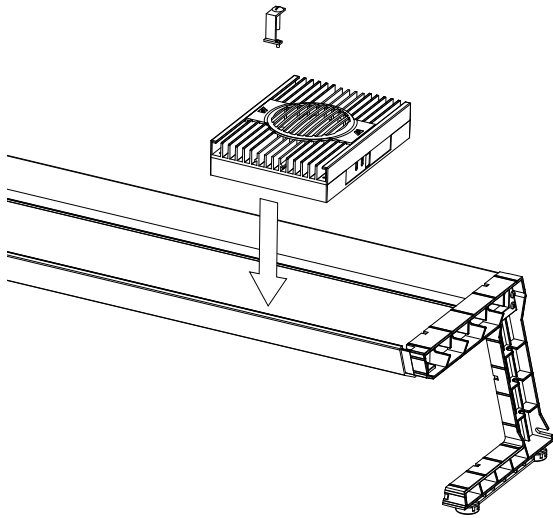

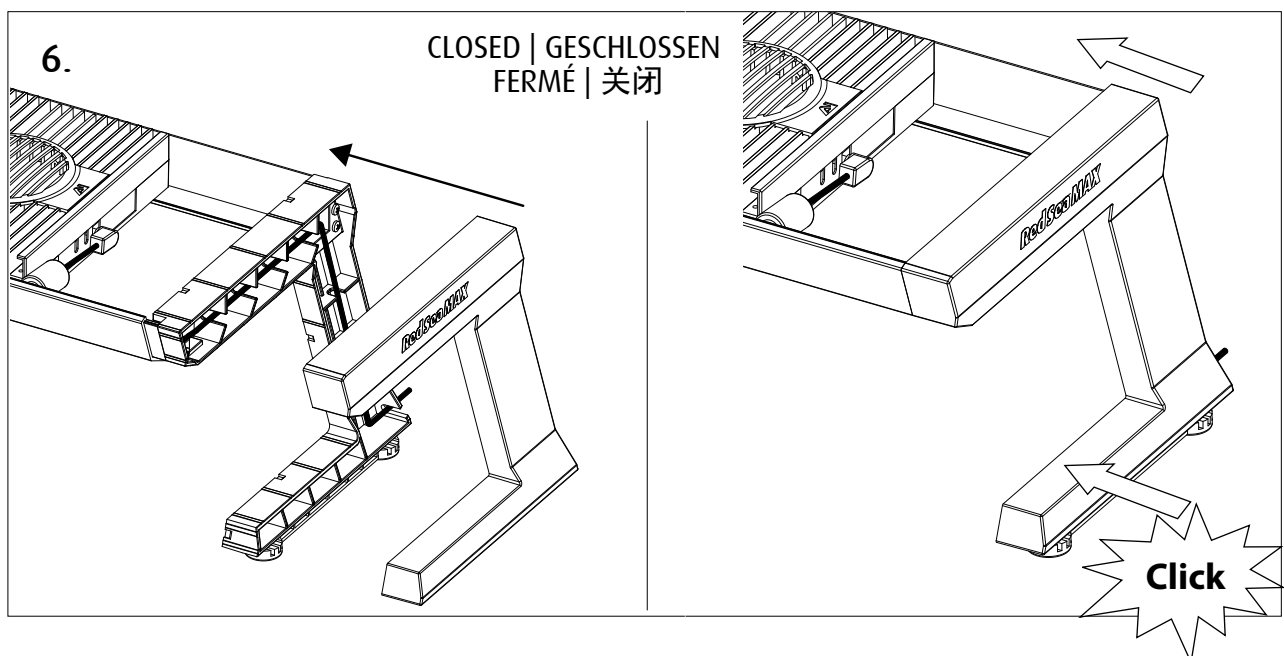
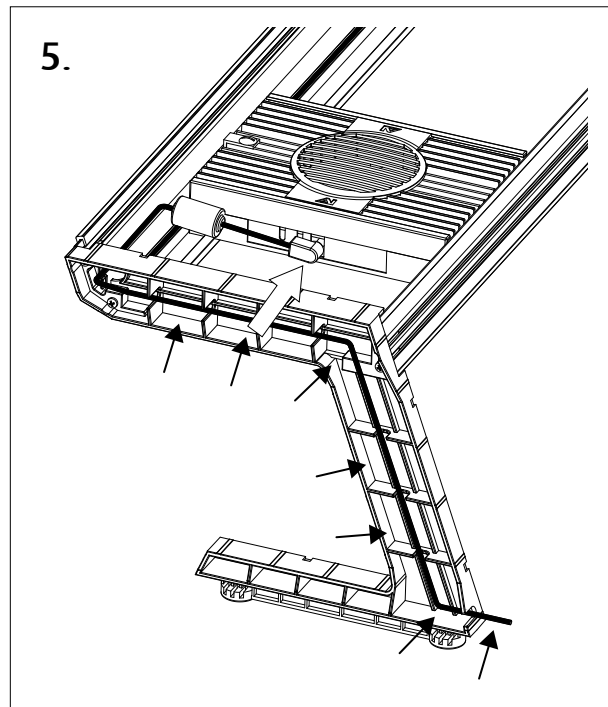
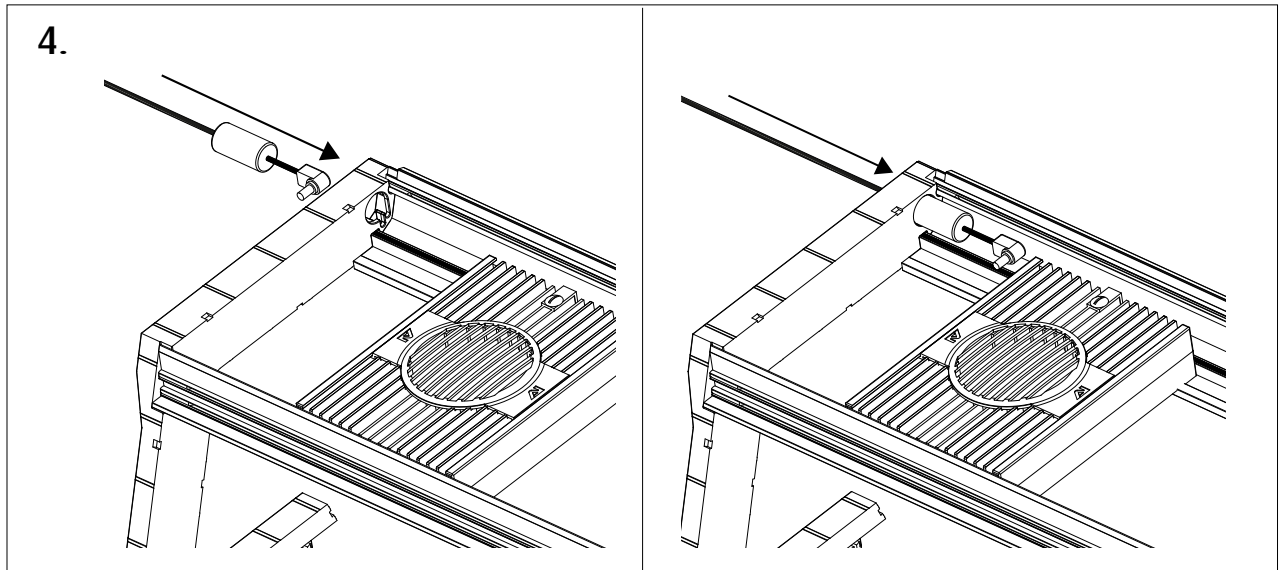

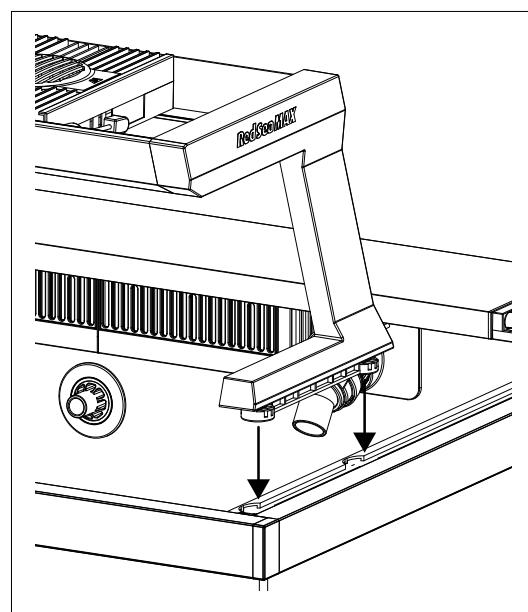
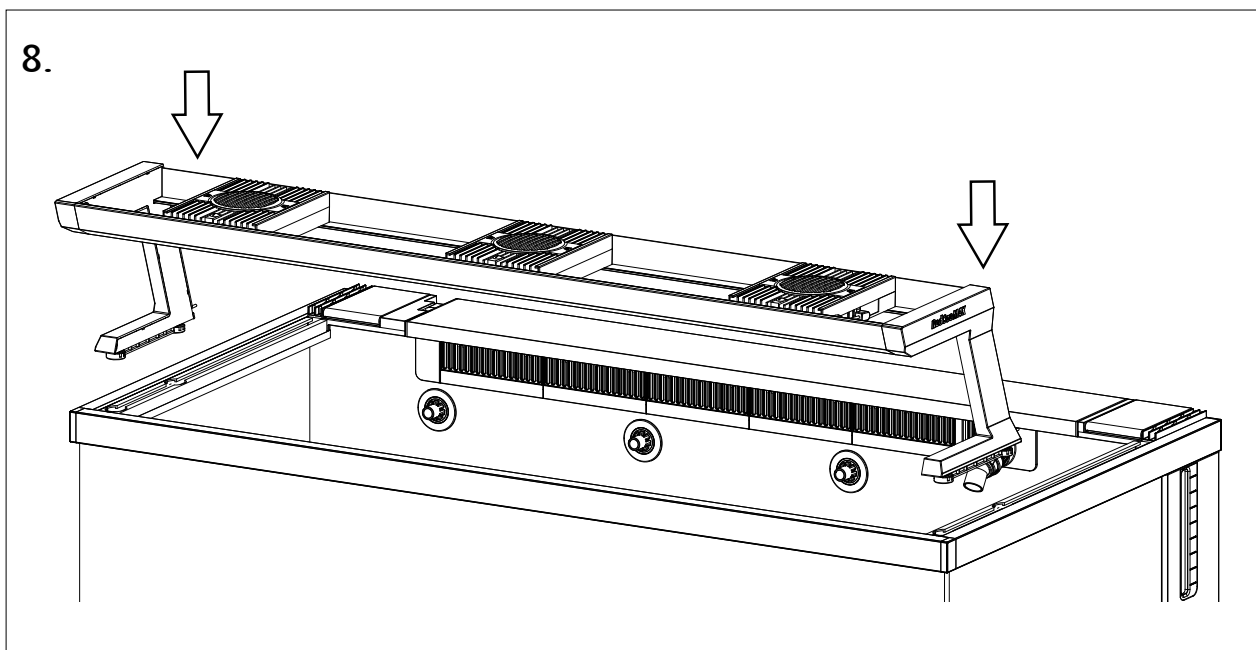
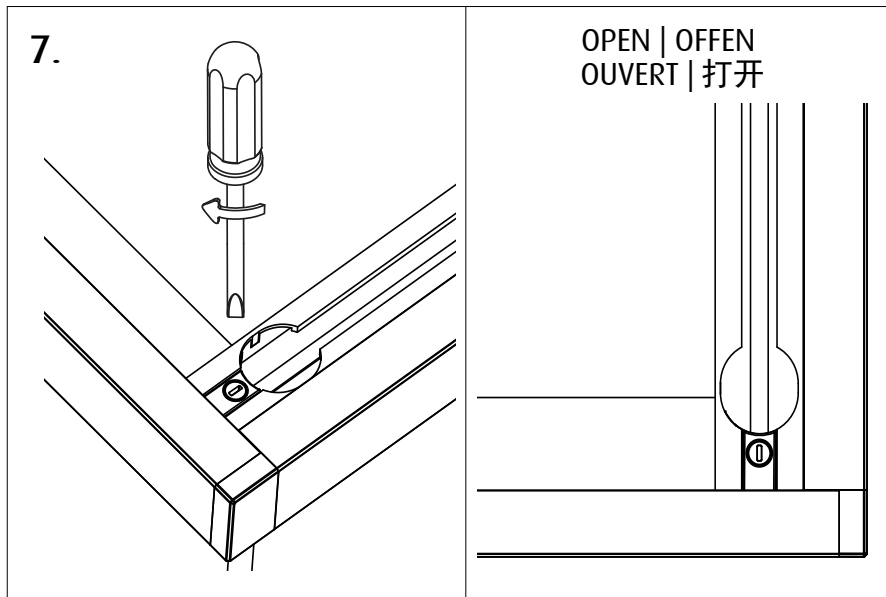

9.

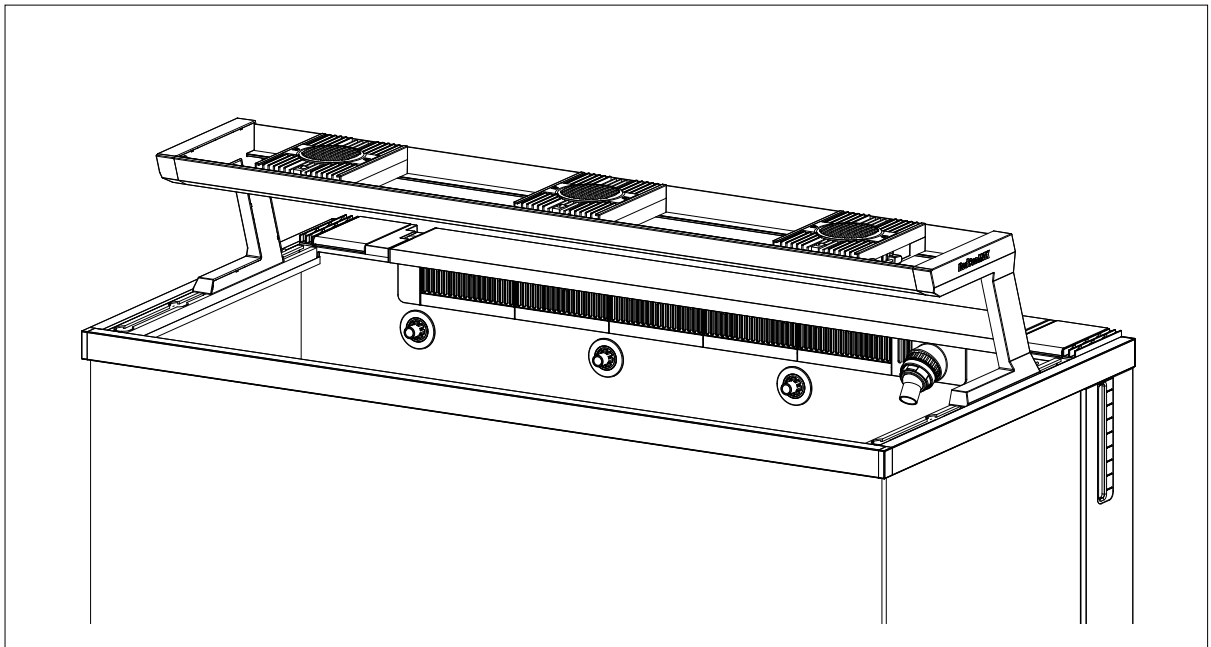
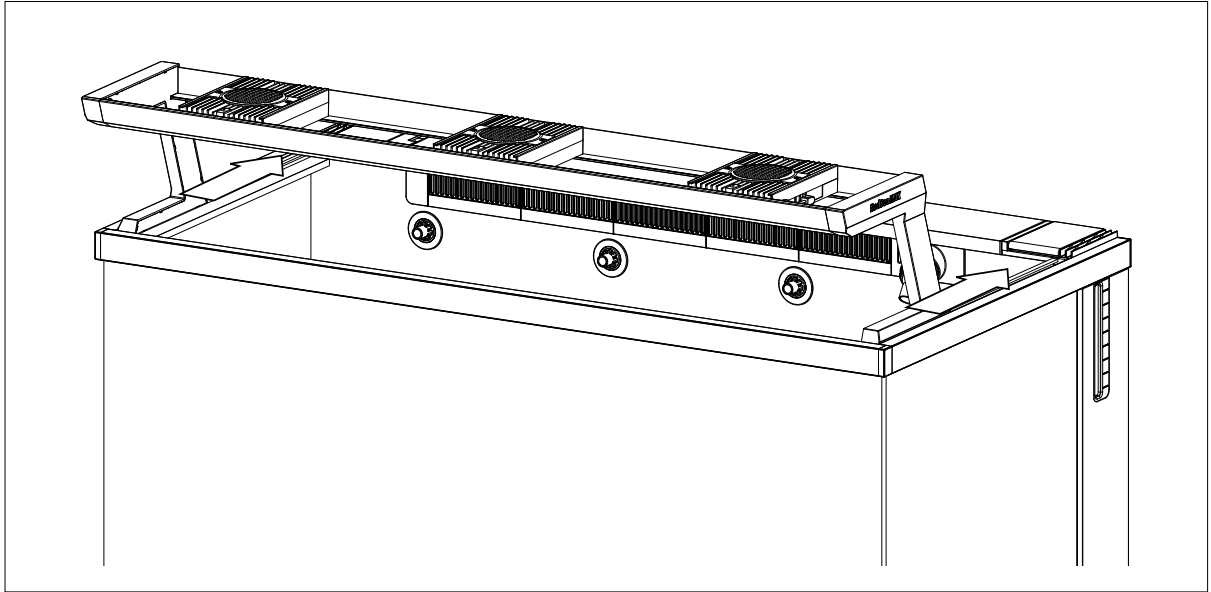

10.

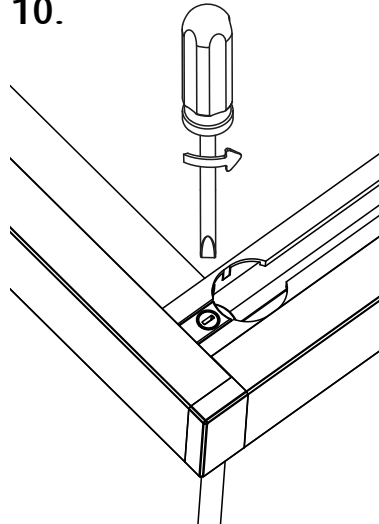

CLOSED | GESCHLOSSEN
FERMÉ | 关闭

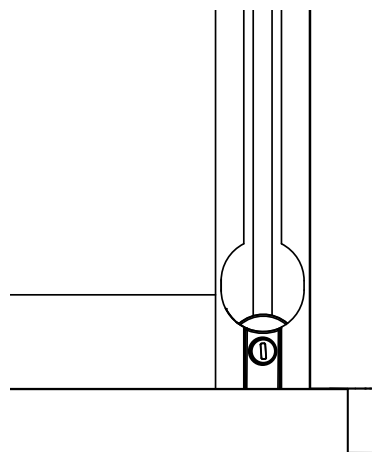

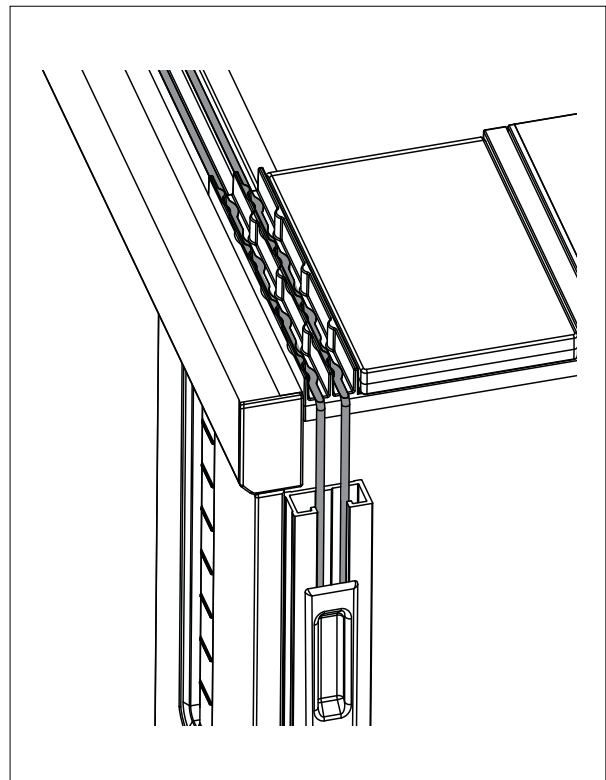
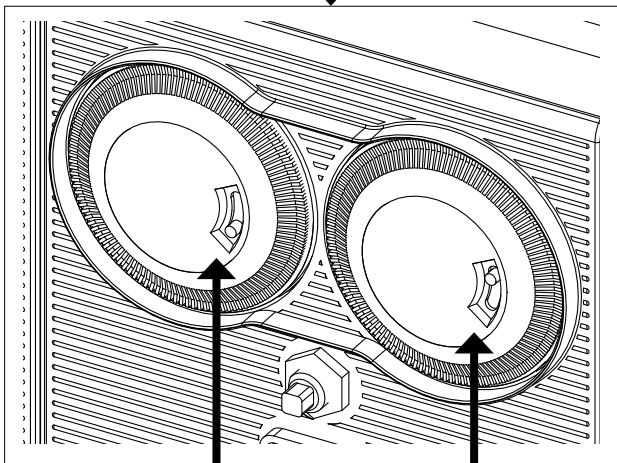
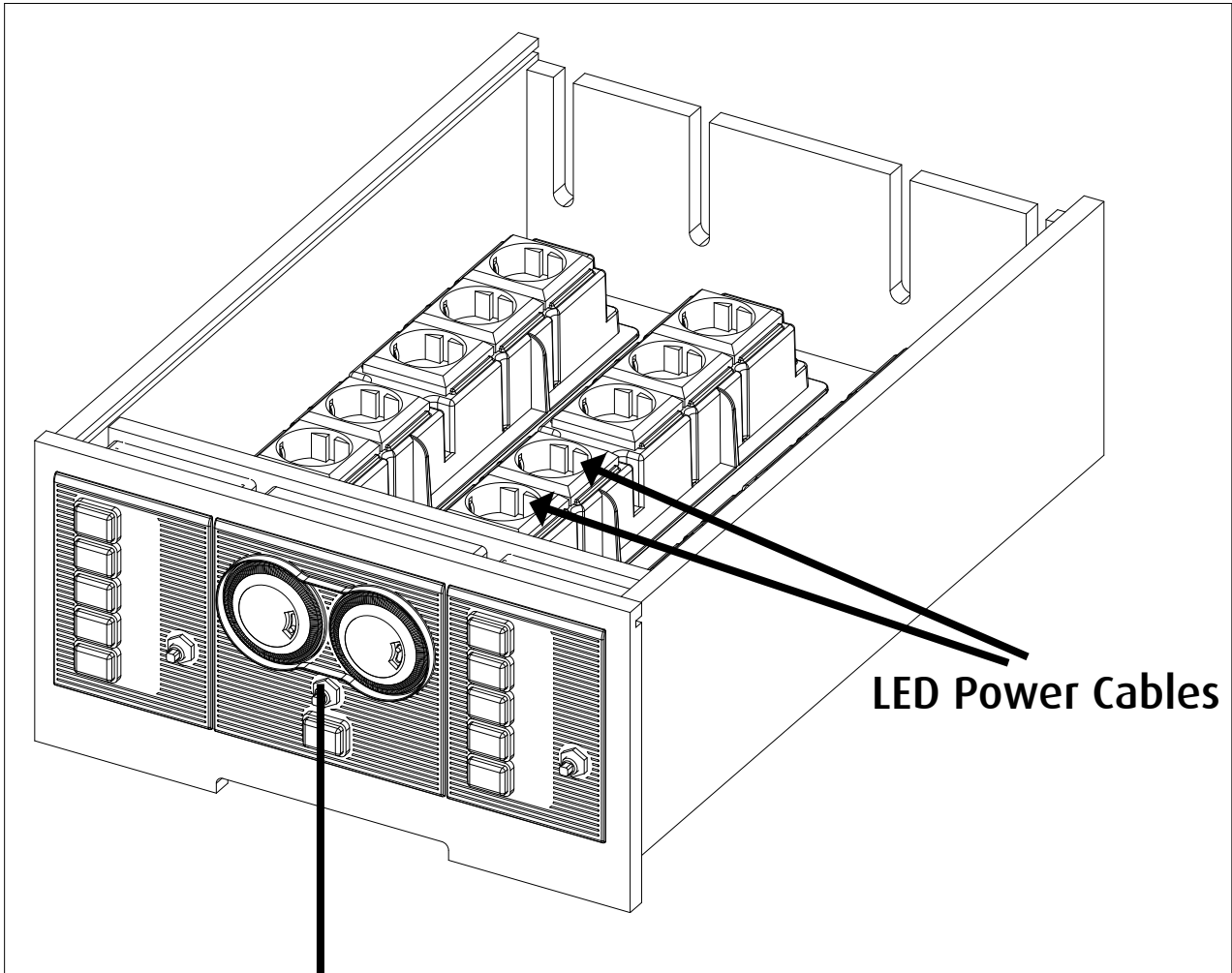

North America

Red Sea U.S.A & Canada
18125 Ammi Trail
Houston, TX 77060
Tel. : +1-888-RED-SEA9
usa.info@redseafish.com

UK & Ireland

Red Sea Aquatics (UK) Ltd
PO Box 1237
Cheddar, BS279AG
Tel. : +44 (0) 203 3711437
Fax : +44 (0) 800 0073169
uk.info@redseafish.com

Europe

Red Sea Europe
ZA de la St-Denis
F-27130 Verneuil s/Avre,
France
Tel: (33) 2 32 37 71 37
eur.info@redseafish.com

Germany & Austria

Red Sea Deutschland
Büro Deutschland
Prinzenallee 7 (Prinzenpark)
40549 Düsseldorf
Tel: 0211-52391 481
info.de@redseafish.com

Asia Pacific

Red Sea Aquatics Ltd
2310 Dominion Centre
43-59 Queen's Road East
Hong Kong
Tel: +86-020-6625 3828
info.china@redseafish.com

China

Red Sea Aquatics (GZ) Ltd.
Block A3, No.33 Hongmian Road,
Xinhua Industrial Park,
Huadu District, Guangzhou City,
China, Postal code 510800.
Tel: +86-020-6625 3828
info.china@redseafish.com



PRINTING INSTRUCTIONS

To print **only** the Hydra 26 HD LED Manual, print pages 142-150.

Page Handling

Copies: 1 Collate

Page Scaling: Multiple pages per sheet

Pages per sheet: 2 by

Page Order: Horizontal

Print page border Auto-Rotate Pages



Red Sea Hydra 26™ HD LED



Scan this QR to register
& activate your Red Sea
Hydra 26™ HD LED

*Hydra TwentySix HD is a registered Trade Mark of AI



Red Sea Hydra 26™ HD LED

Connection and set-up of Wi-Fi controller

Safety warnings

Incorrect use of this device could cause bodily injury or death. Read and follow all of the safety guidelines in the Red Sea MAX® manual before assembling and/or using this LED module.

Do not attempt any repairs to the modules. Any unauthorized repairs will void your warranty.

Important Notes:

Install the LED modules above the aquarium as instructed in the MAX® Installation and operation manual.

Note down the unique serial number (RSMAX26-D89760XXXXXX) for each LED module as shown on the label located above the DC power socket.

When appropriate, switch the light switch on the power center to the **ON** position and follow the instructions to connect the LED modules to your smartphone, tablet or Wi-Fi enabled computer.

On initial power-up, all LEDs will switch on in an un-configured mode.

For MAX® systems with multiple LED modules, designate the first LED module you connect to the Wi-Fi as the “parent” and thereafter add the other modules as “children”.

Initial Connection:

Smartphones and tablets:

1. Download the iOS or Android “myAI” apps at: http://www.redseafish.com/my_ai/ or Scan the QR:
2. From your device, go to Wi-Fi settings and select one of the networks labeled with the serial number of the LED module. It may take a few moments to appear.
3. Open the “myAI” app and follow the on-screen instructions to finish connecting the LED modules to your network.



Wi-Fi enabled computers

1. Register your product at: www.redseafish.com/max-register
2. From your computer, connect to one of the networks labeled with the serial number of the LED module. It may take a few moments to appear.
3. In your browser connect to <http://RSMAX26-D89760XXXXXX.local> (XXXXXX from the serial number) and follow the on-screen instructions to finish connecting the LED modules to your network.

Controller settings

The controller provides automatic and manual modes for the lights.

When the “Auto” mode is selected the LED module will vary spectrum and intensity according to the 24 hour cycle that you program.

When the “Manual” mode is selected the LED module will operate continuously at the fixed spectrum and intensity as set on the manual setup screen. Moving to “Manual” from “Auto” will show the current setting of all color channels. Any changes made during “Manual” mode will be deleted when returning to “Auto” mode.

Spectrum and Intensity

Select the “Manual” control option and see the effect of raising/lowering the intensity of individual color channels and the effect of various combinations. (Note: For systems with multiple LED modules, “child” units should change together with the “parent”) The HD function automatically reallocates the “unused” power from one color channel to others up to the maximum allowable power for the other channels. The reallocation depends on the prior relative intensity of the channels and therefore the sequence in which color intensity changes are made will affect the final result.

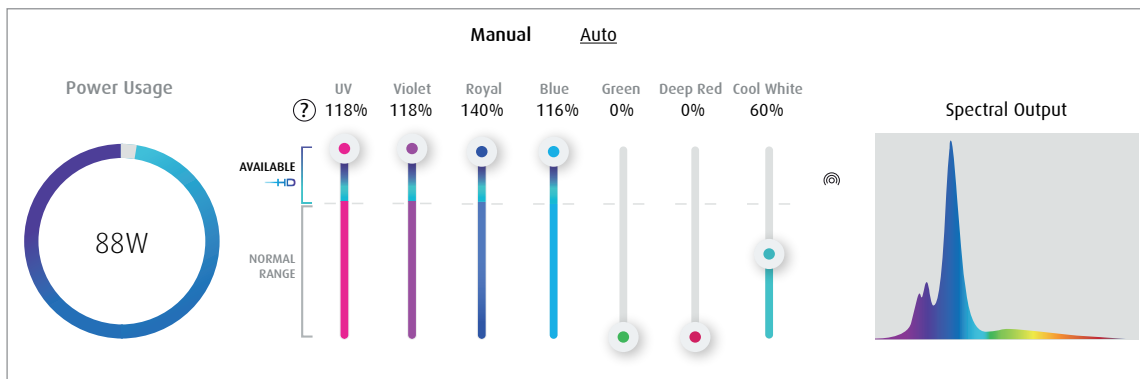

Recommended REEF-SPEC® setting for maximum power for Reef aquariums.

Red Sea Hydra 26™ HD LED

Day / Night Programming

Before setting up your 24 hour program refer to the general programming guidelines given in the MAX® instruction manual.

1. Set the Date, Time and Time zone.
2. Select the “Easy Setup” option to program the basic daily cycle. Use the right slider button to set the desired maximum “Day” intensity for each color channel. Set the “Nite” intensity for each color channel to by sliding the left slider button to the left.
Set the maximum intensity suitable for your tank and then use the acclimation option as described below to gradually acclimate your corals to the LED lighting.
3. Set the “Lunar” option to “OFF”. If you wish to have moonlight at night manually add the desired light to the program graph.

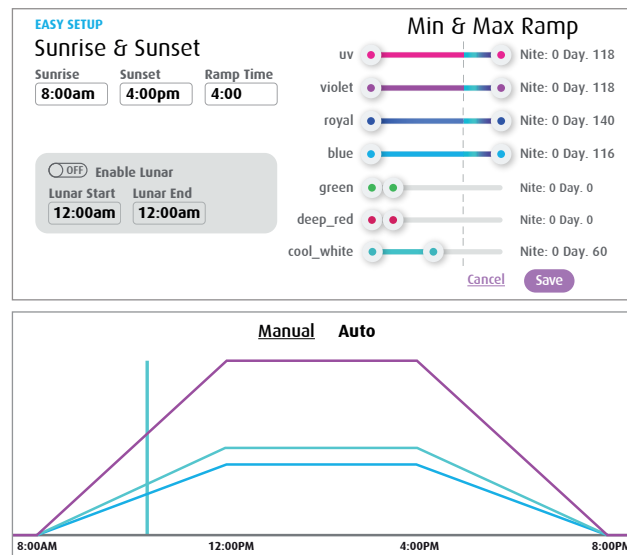

To manually add program points to the graph, drag the green bar to the desired time, Right-click to open the color intensity set window for that point, then click on save or close window to exit.

Manually adding the moonlight setting to the 24 hour program

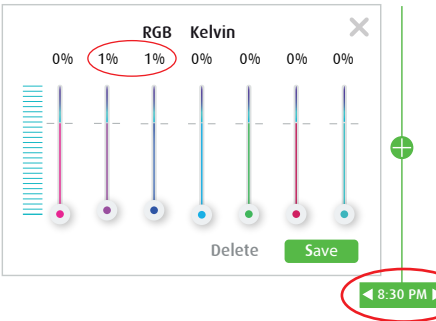
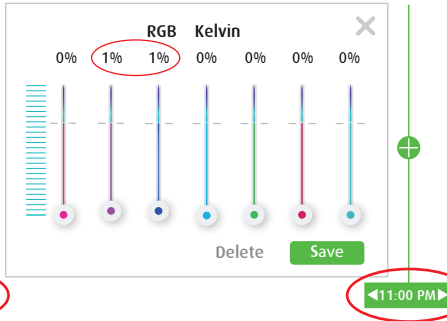
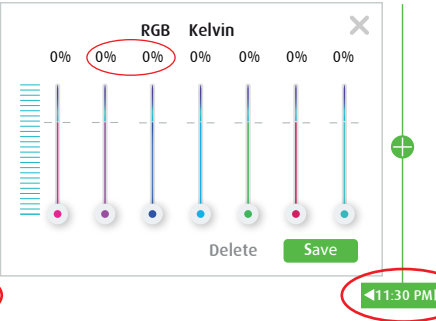
Moonlight - Maximum Intensity	Moonlight - Begin ramp-down	Begin Night (dark period)
 <p>0% 1% 1% 0% 0% 0% 0%</p> <p>RGB Kelvin</p> <p>Delete Save</p> <p>8:30 PM</p>	 <p>0% 1% 1% 0% 0% 0% 0%</p> <p>RGB Kelvin</p> <p>Easy Setup</p> <p>Delete Save</p> <p>11:00 PM</p>	 <p>0% 0% 0% 0% 0% 0% 0%</p> <p>RGB Kelvin</p> <p>Easy Setup</p> <p>Delete Save</p> <p>11:30 PM</p>

Red Sea Hydra 26™ HD LED

Acclimation

To set and activate the acclimation option, click on “EDIT” and then click on the ON/OFF button.

Set the Start and End date for the acclimation period.

Move the cursor to the right hand slider to set the starting percentage reduction equally for all color channels. i.e. if you want to start at 60% intensity set the “Starting Percentage Reduction” to 40%.

Click on “Save” to exit the window. The dates of the active acclimation period will now be shown on the control screen. The acclimation function will automatically switch off at the end of the set acclimation period.

The acclimation settings can be adjusted or switched off at any time.

Button Function

To reset the LED Module’s network setting, press and hold the button until the LED indicator blinks green.

To reset the LED Module to its factory default settings, press and hold the button until the LED indicator blinks red

Note: When the LED Module is in an un-configured state, all of the LEDs will be permanently on. Pressing the button will increase all color channel intensities by 20%.

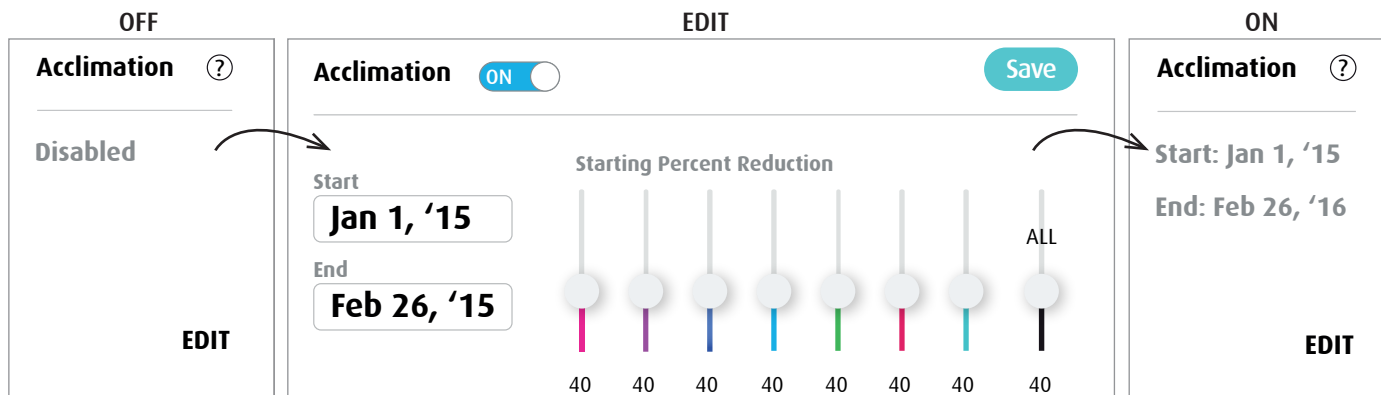

LED Indicator States

Pulsing

● Blue + ● Green
booting

● Green
Parent attempting to connect to home network

● Blue
Child attempting to connect to home network

Blinking

● Green
Parent with schedule hosting access point.
Not connected to home network

● Blue
Child fails to connect to network. Hosting an access point

● Red
Contact Tech support

● Red + ● Green + ● Blue
Firmware update

● Blue + ● Green
Un-configured state

Solid

● Blue + ● Green
Configuring children

● Green
Potential parent successfully connected to a home network

● Blue
Child successfully connected to home network

● Red
Thermal cooldown

Maintenance

- Do not lay objects on top of the LED Module or power supply
- Do not lay the LED Module on objects while powered on
- Inspect the LED Module regularly
- Unplug the LED Module from the outlet when cleaning to prevent any shock hazards
- Wipe the LED Module with a damp cloth once a week. DO NOT use Ammonia based cleaners. Avoid the power plug area. A can of compressed air may be used to blow dust out of the heat sink fins. Wiping and blowing unwanted buildup will help prevent salt creep and hard water spots from accumulating.
- Do not allow any liquids to pool on top of or inside the LED Module.

For instruction videos, FAQs and support, visit:

support.aquillumination.com



Scan this QR to register & activate your Red Sea Hydra 26™ HD LED



Scan this QR
to register &
activate your
Red Sea Hydra
26™ HD LED

North America

Red Sea U.S.A & Canada
18125 Ammi Trail
Houston, TX 77060
Tel. : +1-888-RED-SEA9
usa.info@redseafish.com

UK & Ireland

Red Sea Aquatics (UK) Ltd
PO Box 1237
Cheddar, BS279AG
Tel. : +44 (0) 203 3711437
Fax : +44 (0) 800 0073169
uk.info@redseafish.com

Europe

Red Sea Europe
ZA de la St-Denis
F-27130 Verneuil s/Avre,
France
Tel: (33) 2 32 37 71 37
eur.info@redseafish.com

Germany & Austria

Red Sea Deutschland
Büro Deutschland
Prinzenallee 7 (Prinzenpark)
40549 Düsseldorf
Tel: 0211-52391 481
info.de@redseafish.com

Asia Pacific

Red Sea Aquatics Ltd
2310 Dominion Centre
43-59 Queen's Road East
Hong Kong
Tel: +86-020-6625 3828
info.china@redseafish.com

China

Red Sea Aquatics (GZ) Ltd.
Block A3, No.33 Hongmian Road,
Xinhua Industrial Park,
Huadu District, Guangzhou City,
China, Postal code 510800.
Tel: +86-020-6625 3828
info.china@redseafish.com



www.redseafish.com